

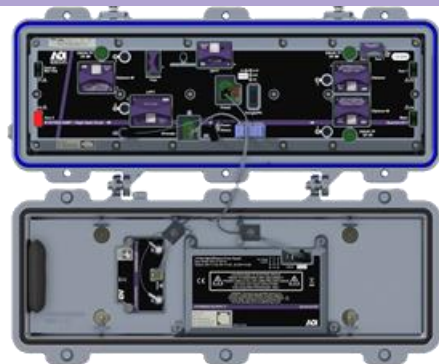

# Quantum18 - 1.8GHz System Amplifier

## INSTALLATION AND OPERATION GUIDE



13139 Jess Pirtle Boulevard, Sugar Land, TX 77478 | T: 281.295.1800







V02102025

# For Your Safety

## EXPLANATION OF WARNING AND CAUTION ICONS.

Avoid personal injury and product damage! Do not proceed beyond any symbol until you fully understand the indicated conditions.

The following warning and caution icons alert you to important information about the safe operation of this product:

	<p>You may find this symbol in the document that accompanies this product. This symbol indicates important operating or maintenance instructions.</p>
	<p>You may find this symbol affixed to the product. This symbol indicates a live terminal where a dangerous voltage may be present; the tip of the flash points to the terminal device.</p>
	<p>You may find this symbol affixed to the product. This symbol indicates a protective ground terminal.</p>
	<p>You may find this symbol affixed to the product. This symbol indicates a chassis terminal (normally used for equipotential bonding).</p>
	<p>You may find this symbol affixed to the product. This symbol warns of a potentially hot surface.</p>
	<p>You may find this symbol affixed to the product and in this document. This symbol indicates an infrared laser that transmits intensity-modulated light and emits invisible laser radiation or an LED that transmits intensity-modulated light.</p>

## IMPORTANT

Please read this entire guide. If this guide provides installation or operation instructions, give particular attention to all safety statements included in this guide.

# Notices

## TRADEMARK ACKNOWLEDGEMENTS

- AOI, the AOI logo, Applied Optoelectronics, the AOI logo, and Quantum Bandwidth are trademarks or registered trademarks of Applied Optoelectronics, Inc. and / or its affiliates in the U.S. and certain other countries.
- All other trademarks mentioned in this document are the property of their respective owners.

## PUBLICATION DISCLAIMER

Applied Optoelectronics, Inc., assumes no responsibility for errors or omissions that may appear in this publication. We reserve the right to change this publication at any time without notice. This document is not to be construed as conferring by implication, estoppel, or otherwise any license or right under any copyright or patent, whether or not the use of any information in this document employs an invention claimed in any existing or later issued patent.

## COPYRIGHT

©2025 Applied Optoelectronics, Inc. All rights reserved. Printed in the United States of America.

Information in this publication is subject to change without notice. No part of this publication may be reproduced or transmitted in any form, by photocopy, microfilm, xerography, or any other means, or incorporated into any information retrieval system, electronic or mechanical, for any purpose, without the express permission of Applied Optoelectronics, Inc.

**Table of Contents**

**For Your Safety** ..... **II**

    EXPLANATION OF WARNING AND CAUTION ICONS..... **II**

    IMPORTANT..... **II**

**Notices**..... **III**

    TRADEMARK ACKNOWLEDGEMENTS..... **III**

    PUBLICATION DISCLAIMER ..... **III**

    COPYRIGHT..... **III**

**Important Safety Instructions** ..... **VIII**

    FOLLOW INSTRUCTIONS AND HEED WARNINGS..... **VIII**

    TERMINOLOGY..... **VIII**

    ELECTRIC SHOCK HAZARD..... **VIII**

    EQUIPMENT PLACEMENT ..... **IX**

    STRAND (AERIAL) INSTALLATION ..... **IX**

    PEDESTAL, SERVICE CLOSET, EQUIPMENT ROOM OR UNDERGROUND VAULT INSTALLATION ..... **IX**

    CONNECTING TO UTILITY AC POWER ..... **IX**

    CONNECTION TO NETWORK POWER SOURCES..... **X**

    AC POWER SHUNTS..... **X**

    EQUIPOTENTIAL BONDING ..... **X**

    GENERAL SERVICING PRECAUTIONS..... **X**

    ELECTROSTATIC DISCHARGE ..... **XI**

    SHUNT REPLACEMENT ..... **XII**

    MODIFICATIONS ..... **XII**

    ACCESSORIES ..... **XII**

    ELECTROMAGNETIC COMPATIBILITY REGULATORY REQUIREMENTS..... **XII**

**EMC COMPLIANCE STATEMENTS** ..... **XIII**

        FCC Statement for Class A Equipment ..... **XIII**

        Industry Canada – Industrie Canadiene Statement ..... **XIII**

        CENELEC / CISPR Statement with Respect to Class A Information Technology Equipment ..... **XIII**

**1. Introduction**..... **1**

**OVERVIEW**.....**2**

        Purpose ..... **2**

        Who Should Use This Document..... **2**

        Qualified Personnel..... **2**

        Scope..... **2**

        EQUIPMENT ..... **2**

Installation and Operation Guide

**DESCRIPTION .....3**

    Characteristics ..... 3

    Power Supply ..... 4

    Input and Output Ports..... 4

    Configuration ..... 4

    High Gain Dual..... 5

    High Gain Balance Triple ..... 5

    RF Test Points..... 6

    AC/DC Power Management ..... 7

**ILLUSTRATIONS.....8**

    System Amplifier Accessories ..... 8

    Ordering Information ..... 11

**BLOCK DIAGRAM .....12**

**2. Installation and Configuration..... 13**

**OVERVIEW.....14**

**BEFORE YOU BEGIN.....15**

        Required Equipment..... 15

        Torque Specifications ..... 16

**AMPLIFIER MODULE COVER .....17**

**MODULE AND HOUSING COMPATABILITY.....17**

        Housing Lid ..... 17

        Housing Base ..... 17

        Housing Dimensions..... 17

**OPENING THE SYSTEM AMPLIFIER HOUSING.....18**

**UPGRADING EXISTING HOUSING SEIZURES .....19**

        To Install the New Housing Seizures..... 20

**UPGRADING AN EXISTING HOUSING LID .....21**

        To Install the New Housing Lid ..... 21

**INSTALLING THE POWER SUPPLY.....23**

        To Install the Power Supply Module..... 23

        To Set the AC Undervoltage Lockout Selector ..... 24

**ATTACHING THE COAXIAL CONNECTORS.....25**

        To Trim the Center Conductor ..... 25

        To Connect the Coaxial Cable Pin Connector to the System Amplifier Housing ..... 26

**INSTALLING THE HOUSING .....27**

        To Install the Housing on a Strand (Aerial) ..... 27

        Signal Flow From Left to Right ..... 27

        Signal Flow From Right to Left ..... 28

        To Install the Housing in a Pedestal..... 29

**INSTALLING ACCESSORIES .....30**

        To Install the Plug-in Signal Director (High Gain Dual Only)..... 30

        Jumpers..... 30

        Splitter..... 30

        8 dB Coupler..... 31

Installation and Operation Guide

12 dB Coupler..... 31

**INSTALLING THE SYSTEM AMPLIFIER MODULE ..... 32**

    To Install the System Amplifier Module..... 32

**REMOVING THE SYSTEM AMP MODULE FROM THE HOUSING ..... 34**

    To Remove the System Amplifier Module ..... 34

**CLOSING THE SYSTEM AMPLIFIER HOUSING..... 35**

    To close the System Amplifier Housing..... 35

    Torquing Sequence ..... 35

**3. Balancing and Setup ..... 36**

**INTRODUCTION ..... 37**

**PREPARING FOR AMPLIFIER SET-UP ..... 38**

**VERIFY/UPDATE AMPLIFIER INFORMATION ..... 40**

**VERIFY/UPDATE AMPLIFIER CONFIGURATION..... 41**

**LOCATION DATA ..... 42**

**DOWNSTREAM PROFILE CONFIGURATION ..... 43**

**DOWNSTREAM AUTO ALIGNMENT ..... 44**

**DOWNSTREAM MANUAL ALIGNMENT..... 45**

**VIEW DOWNSTREAM SPECTRUM ..... 46**

**UPSTREAM ALIGNMENT..... 47**

**UPSTREAM ALIGNMENT...continued..... 48**

**CASCADE ALSC ACTIVATION ..... 49**

**TEST POINTS ..... 50**

**DIAGNOSTICS..... 51**

**4. TROUBLESHOOTING..... 52**

**INTRODUCTION ..... 53**

**NO AC POWER ..... 54**

        No AC Power Troubleshooting Table ..... 55

**NO DC POWER ..... 56**

**NO DC POWER TROUBLE SHOOTING TABLE ..... 56**

**NO FORWARD RF SIGNAL ..... 57**

        No Forward RF Signal Troubleshooting Table..... 57

**LOW OR DEGRADED FORWARD RF SIGNAL ..... 58**

        Low or Degraded Forward RF Signal Troubleshooting Table..... 58

**NO REVERSE RF SIGNAL..... 59**

        No Reverse RF Signal Troubleshooting Table..... 59

**LOW OR DEGRADED REVERSE RF SIGNAL..... 60**

Installation and Operation Guide

Low or Degraded Reverse RF Signal Troubleshooting Table..... 60

**5. CUSTOMER SUPPORT INFORMATION ..... 62**

**IF YOU HAVE QUESTIONS .....62**

**RF SPLIT UPGRADE APPLICATION NOTE..... 1**

**APPENDIX A: RF SPLIT UPGRADE APPLICATION NOTE ..... 1**

**BEFORE YOU BEGIN.....2**

            Introduction ..... 2

            Purpose ..... 2

            Qualified Personnel ..... 2

            Related Publications..... 2

            Components Required to Make the Split Change ..... 3

            Equipment Required to Make the Split Change ..... 3

**UPGRADING THE RF SPLIT IN THE 1.8GHz SYSTEM AMPLIFIER .....4**

            Upgrading the Amplifier Module..... 4

**CONNECT TO QUANTUMLINK LOCAL FOR CONFIGURATION AND VERIFICATION .....6**

**TO CLOSE THE SYSTEM AMPLIFIER HOUSING .....12**

**TRANSPONDER INSTALLATION APPLICATION NOTE..... 1**

**APPENDIX B: TRANSPONDER INSTALLATION APPLICATION NOTE ..... 1**

**BEFORE YOU BEGIN.....2**

            Introduction ..... 2

            Purpose ..... 2

            Audience ..... 2

            Qualified Personnel ..... 2

            Related Publications..... 2

            Equipment Required ..... 2

**INSTALLING THE TRANSPONDER.....3**

**TO CLOSE THE SYSTEM AMPLIFIER HOUSING .....4**

**GLOSSARY ..... 1**

# Important Safety Instructions

Carefully read all safety and operating instructions before operating this equipment and retain them for future reference.

## FOLLOW INSTRUCTIONS AND HEED WARNINGS

Follow all operating and use instructions. Pay attention to all warnings and cautions in the operating instructions, as well as those that are affixed to this equipment.

## TERMINOLOGY

The terms defined below are used in this document. The definitions given are based on those found in the safety standards

<p><b>Service Personnel:</b></p>	<p>The term <b>service personnel</b> applies to trained and qualified individuals who are allowed to install, replace, or service electrical equipment. The service personnel are expected to use their experience and technical skills to avoid possible injury to themselves and others due to hazards that exist in service and restricted access areas.</p>
<p><b>User and Operator:</b></p>	<p>The terms <b>user</b> and <b>operator</b> apply to persons other than service personnel.</p>
<p><b>Ground(ing) and Earth(ing):</b></p>	<p>The terms <b>ground(ing)</b> and <b>earth(ing)</b> are synonymous. This document uses ground(ing) for clarity, but it can be interpreted as having the same meaning as earth(ing).</p>

## ELECTRIC SHOCK HAZARD

This equipment meets applicable safety standards.

	<p><b>WARNING:</b></p> <p>To reduce risk of electric shock, perform only the instructions that are included in the operating instructions. Refer all servicing to qualified service personnel only.</p>
---	---

Electric shock can cause personal injury or even death. Avoid direct contact with dangerous voltages at all times.

Know the following safety warnings and guidelines:

- Only qualified service personnel are allowed to perform equipment installation or replacement.
- Only qualified service personnel are allowed to remove chassis covers and access any of the components inside the chassis.



Installation and Operation Guide

**EQUIPMENT PLACEMENT**



**WARNING:**

Avoid personal injury and damage to this equipment. An unstable mounting surface may cause this equipment to fall.

To protect against equipment damage or injury to personnel, comply with the following:

- Install this equipment in a restricted access location (access restricted to service personnel).
- Make sure the mounting surface or rack is stable and can support the size and weight of this equipment.

**STRAND (AERIAL) INSTALLATION**



**CAUTION:**

Be aware of the size and weight of strand-mounted equipment during the installation operation.

Ensure that the strand can safely support the equipment's weight.

**PEDESTAL, SERVICE CLOSET, EQUIPMENT ROOM OR UNDERGROUND VAULT INSTALLATION**



**WARNING:**

Avoid the possibility of personal injury. Ensure proper handling / lifting techniques are employed when working in confined spaces with heavy equipment.

- Ensure this equipment is securely fastened to the mounting surface or rack where necessary to protect against damage due to any disturbance and subsequent fall.
- Ensure the mounting surface or rack is appropriately anchored according to manufacturer's specifications.
- Ensure the installation site meets the ventilation requirements given in the equipment's data sheet to avoid the possibility of equipment overheating.
- Ensure the installation site and operating environment is compatible with the equipment's International Protection (IP) rating specified in the equipment's data sheet.

**CONNECTING TO UTILITY AC POWER**

**IMPORTANT:** *If this equipment is Class I equipment, it must be grounded.*

- Connect this equipment only to the power sources that are identified on the equipment-rating label, which is normally located close to the power inlet connector(s).

## CONNECTION TO NETWORK POWER SOURCES

Refer to this equipment's specific installation instructions in this manual or in companion manuals in this series for connection to network ferro-resonant AC power sources.

## AC POWER SHUNTS

AC power shunts may be provided with this equipment.

**IMPORTANT:** *The power shunts (where provided) must be removed before installing modules into a powered housing. With the shunts removed, power surge to the components and RF-connectors is reduced.*



**CAUTION:**

RF connectors and housing seizure assemblies can be damaged if shunts are not removed from the equipment before installing or removing modules from the housing. A red shunt indicates the input power port.

## EQUIPOTENTIAL BONDING

If this equipment is equipped with an external chassis terminal marked with the IEC 60417-5020 chassis icon () , the installer should refer to CENELEC standard EN 50083-1 or IEC standard IEC 60728-11 for correct equipotential bonding connection instructions.

## GENERAL SERVICING PRECAUTIONS



**WARNING:**

Avoid electric shock! Opening or removing this equipment's cover may expose you to dangerous voltages.



**CAUTION:**

These servicing precautions are for the guidance of qualified service personnel only. To reduce the risk of electric shock, do not perform any servicing other than that contained in the operating instructions unless you are qualified to do so. Refer all servicing to qualified service personnel.

Be aware of the following general precautions and guidelines.

### 1. SERVICING

Servicing is required when this equipment has been damaged in any way, such as power supply cord or plug is damaged, liquid has been spilled or objects have fallen into this equipment, this equipment has been exposed to rain or moisture, does not operate normally, or has been dropped.

## Installation and Operation Guide

**2. WRISTWATCH AND JEWELRY**

For personal safety and to avoid damage of this equipment during service and repair, do not wear electrically conducting objects such as a wristwatch or jewelry.

**3. LIGHTNING**

Do not work on this equipment, or connect or disconnect cables, during periods of lightning.

**4. LABELS**

Do not remove any warning labels. Replace damaged or illegible warning labels with new ones.

**5. COVERS**

Do not open the cover of this equipment and attempt service unless instructed to do so in the instructions. Refer all servicing to qualified service personnel only.

**6. MOISTURE**

Do not allow moisture to enter this equipment.

**7. CLEANING**

Use a damp cloth for cleaning.

**8. SAFETY CHECKS**

After service, assemble this equipment and perform safety checks to ensure it is safe to use before putting it back into operation.

**ELECTROSTATIC DISCHARGE**

Electrostatic discharge (ESD) results from the static electricity buildup on the human body and other objects. This static discharge can degrade components and cause failures.

Take the following precautions against electrostatic discharge:

- Use an anti-static bench mat and a wrist strap or ankle strap designed to safely ground ESD potentials through a resistive element.
- Keep components in their anti-static packaging until installed.
- Avoid touching electronic components when installing a module.

## Installation and Operation Guide

## SHUNT REPLACEMENT

To replace a shunt, comply with the following:

- Disconnect the power before changing shunts.
- Identify and clear the condition that caused the original shunt failure.
- Always use a shunt of the correct type and rating.

## MODIFICATIONS

This equipment has been designed and tested to comply with applicable safety, laser safety, and EMC regulations, codes, and standards to ensure safe operation in its intended environment. Refer to this equipment's data sheet for details about regulatory compliance approvals.

Do not make modifications to this equipment. Any changes or modifications could void the user's authority to operate this equipment.

Modifications have the potential to degrade the level of protection built into this equipment, putting people and property at risk of injury or damage. Those persons making any modifications expose themselves to the penalties arising from proven non-compliance with regulatory requirements and to civil litigation for compensation in respect of consequential damages or injury.

## ACCESSORIES

Use only attachments or accessories specified by the manufacturer.

## ELECTROMAGNETIC COMPATIBILITY REGULATORY REQUIREMENTS

This equipment meets applicable electromagnetic compatibility (EMC) regulatory requirements. Refer to this equipment's data sheet for details about regulatory compliance approvals. EMC performance is dependent upon the use of correctly shielded cables of good quality for all external connections, except the power source, when installing this equipment.

- Ensure compliance with cable / connector specifications and associated installation instructions were given elsewhere in this manual.

## EMC COMPLIANCE STATEMENTS

Where this equipment is subject to USA FCC and / or Industry Canada rules, the following statements apply:

### FCC Statement for Class A Equipment

This equipment has been tested and found to comply with the limits for a Class A digital device, pursuant to Part 15 of the FCC Rules. These limits are designed to provide reasonable protection against harmful interference when this equipment is operated in a commercial environment.

This equipment generates, uses, and can radiate radio frequency energy and, if not installed and used in accordance with the instruction manual, may cause harmful interference to radio communications. Operation of this equipment in a residential area is likely to cause harmful interference in which case users will be required to correct the interference at their own expense.\

### Industry Canada – Industrie Canadienne Statement

This apparatus complies with Canadian ICES-003.

Cet appareil est conforme à la norme NMB-003 du Canada.

### CENELEC / CISPR Statement with Respect to Class A Information Technology Equipment

This is a Class A equipment. In a domestic environment this equipment may cause radio interference in which case the user may be required to take adequate measures.

# 1. Introduction

## In this Chapter...

OVERVIEW.....2

DESCRIPTION .....3

ILLUSTRATIONS.....8

BLOCK DIAGRAM .....12

## Installation and Operation Guide

**OVERVIEW**

The Quantum18 1.8 GHz Broadband Amplifier Platform includes a variety of RF amplifiers that address the needs of today's broadband networks. All Quantum18 1.8 GHz System Amplifiers provide superior two-way performance and reliability combined with a user-friendly layout.

This chapter introduces the Quantum18 1.8 GHz System Amplifier and describes its main components, configuration options, and accessories.

**Purpose**

This guide provides instructions for installing, configuring, setting up, and troubleshooting the Quantum18 1.8 GHz System Amplifier.

**Who Should Use This Document**

This document is intended for authorized service personnel who have experience working with similar equipment. The service personnel should have the appropriate background and knowledge to complete the procedures described in this document.

**Qualified Personnel****WARNING:**

Allow only qualified and skilled personnel to install, operate, maintain, and service this product. Otherwise, personal injury or equipment damage may occur.

Only appropriately qualified and skilled personnel should attempt to install, operate, maintain, and service this product.

**Scope**

This guide discusses the following topics:

- Description of the Quantum18 1.8 GHz System Amplifier.
- Installing and configuring the system amplifier.
- Balancing and setup of system amplifier forward and reverse signal paths.
- Troubleshooting the system amplifier.
- Customer support information.
- Descriptions of configuration options and accessories.

**EQUIPMENT**

The following equipment may be necessary to perform some troubleshooting procedures:

- Digital voltmeter to measure voltages. Longer test lead extensions may be required to reach into shunt base locations in amplifier module
- Spectrum analyzer or a field strength meter to measure RF levels.
- RF Test point probe, to access test points.
- Viavi "ONX-630" meter with "DOCSIS Expert" option.

## Installation and Operation Guide

**DESCRIPTION**

The Quantum18 1.8 GHz System Amplifier is available in the following amplifier type:

- High Gain Dual (HGD)
- High Gain Balanced Triple (HGBT)

The Quantum18 1.8 GHz System Amplifier is available in the following reverse path splits:

- 85 / 105 MHz
- 204 / 258 MHz
- 396 / 492 MHz
- 492 / 606 MHz
- 684 / 834 MHz

**Characteristics**

Quantum18 1.8 GHz System Amplifier modules have the following characteristics:

- -20 dB test points, located electrically outside of the diplex filter, provide for testing of FWD output signals and REV input signals without disrupting normal operation housing lids allow external test point access.
- Housing lids allow external test point access
- Spring-loaded seizure assemblies allow coax connectors to be installed or removed without removing the amplifier chassis or spring-loaded mechanism from the housing base.
- Direct module plug-in to the housing provides superior heat sinking.
- Symmetrical housing and modules provide convenient mounting:
- System Amplifier housings that can be installed facing either toward or away from the street.
- AC circuitry provides 15 A of steady-state current capability that can withstand 25 A of peak current (for a maximum of two hours).
- Surge-resistant circuitry provides improved resistance to high-voltage transients.
- Chromated housing protects outdoor equipment in coastal areas and other corrosive environments.
- Compatible with existing Quantum12 System Amplifier back housing.
- Network ingress circuitry to support reverse path noise troubleshooting – “wink” switch
- Automatic Level & Slope Control (ALSC) to achieve output RF profile
- Easy frequency split upgrade with simple plug-in module changes. (Input Diplexer, Output Diplexer, HPFT and LPFT)



## Power Supply

The DC power supply has the following features:

- Located in housing lid for ease of maintenance.
- AC and DC test points provided on the amplifier module.
- Input Power Voltages: 35 to 90 VAC.
- Selectable AC undervoltage lockout feature
  - The 30-volt lockout is for 60-volt systems
  - The 40 (factory default) and 50-volt lockout positions are for 90-volt systems (field configurable by moving a jumper)
- Not compatible with previous Quantum12 System Amplifier power supply.

## Input and Output Ports

The Quantum18 1.8 GHz System Amplifier has one input and three output ports.

## Configuration

The Quantum18 1.8 GHz System Amplifier is pre-configured with the following:

- Diplex Filters
- Frequency split dependent High Pass Filter Trim and Low Pass Filter Trim
- Forward Universal Trim (ships with 0dB) and Forward Universal Trim (ships with 6dB).
- 6kV crowbar surge protector, under Launch Amplifier cover.

### High Gain Dual

These amplifiers have one input port and two or three output ports. The number of output ports is determined by the type of Signal Director installed:

- Jumper – enables output ports Aux 1 or Aux2 and Main.
- Two-way splitter – enables both Aux1 and Aux2 ports to be ~4dB lower in gain than the Main port.
- 8 dB directional coupler – enables either Aux1 or Aux2 ports to be 8dB lower in gain than the Main port, while the Aux port is about 2dB lower than the Main port.
- 10 dB directional coupler – enables either Aux1 or Aux2 ports to be 10dB lower in gain than the Main port, while the other Aux port is about 2dB lower in gain than the Main port.
- 12 dB directional coupler – enables either Aux1 or Aux2 ports to be 12dB lower in gain than the Main port, while the other Aux port is about 2dB lower in gain than the Main port.

The HGD Signal Director location is circled in red below.

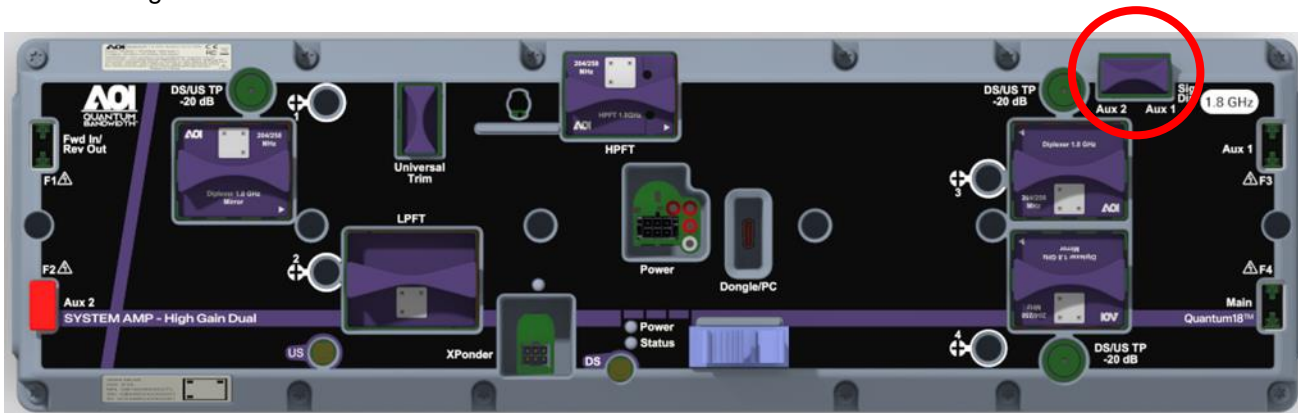

Figure 1- 1: Signal Director location

### High Gain Balance Triple

This amplifier has one input port and three output ports.

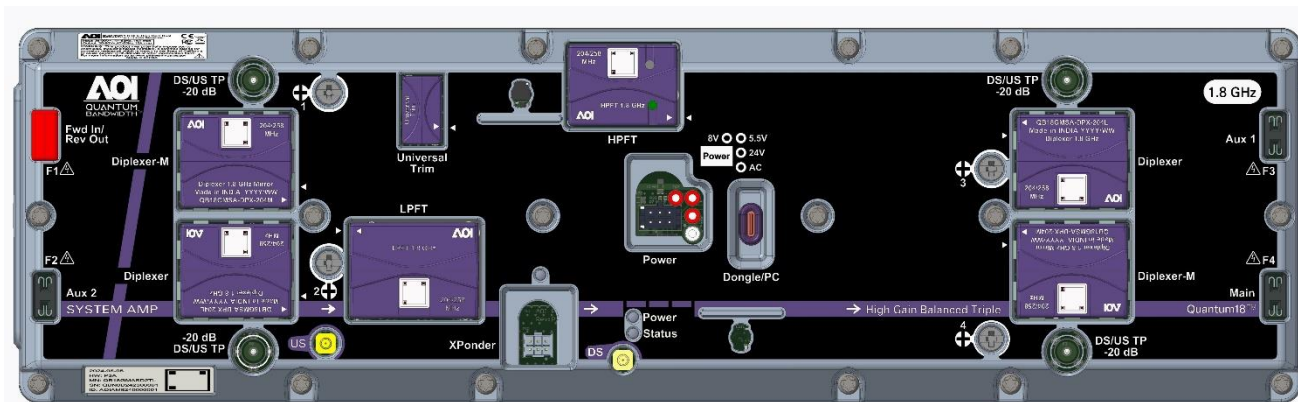
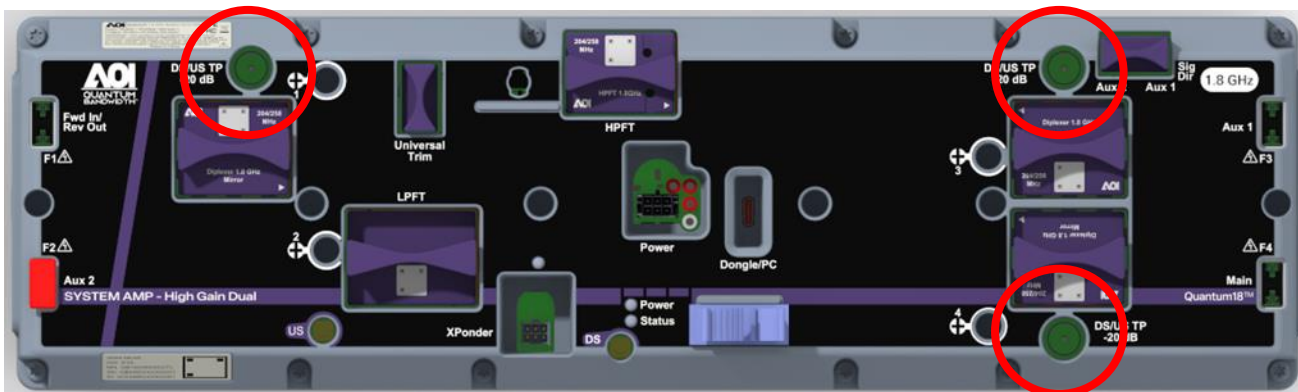

Figure 1- 2: HGBT Amplifier Module

**RF Test Points**

There are three (3) RF test points on the Quantum18 1.8 GHz HGD System Amplifier module. -20 dB test points, located electrically outside of the diplex filter, provide for testing both input and output signals for both reverse and forward signals without disrupting normal operation. The DS/US Test points are circled in red below.



**Figure 1- 3: HGD RF Test Points**

There are three (4) RF test points on the Quantum18 1.8 GHz HGBT System Amplifier module. -20 dB test points, located electrically outside of the diplex filter, provide for testing both input and output signals for both reverse and forward signals without disrupting normal operation. The DS/US Test points are circled in red below.

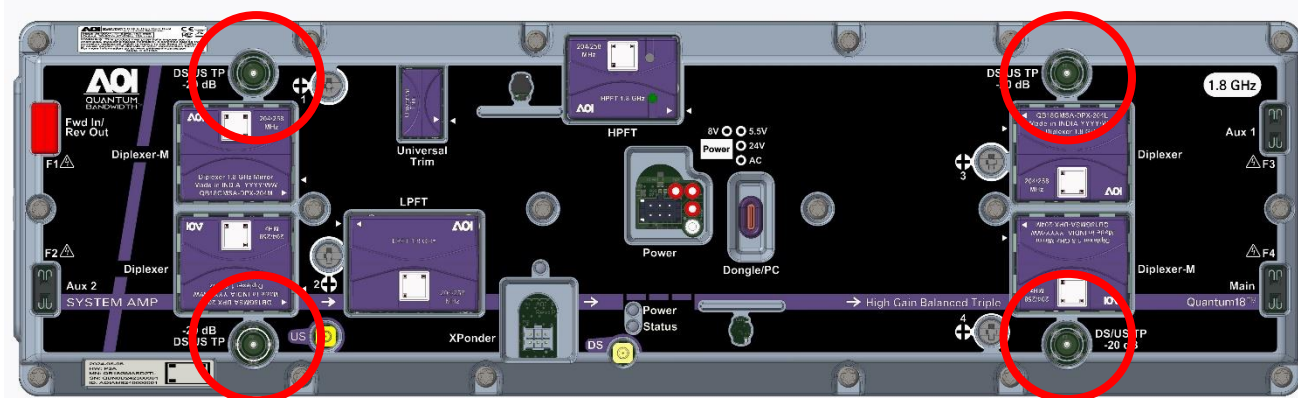

**Figure 1- 4: HGBT RF Test Points**

Installation and Operation Guide

**AC/DC Power Management**

The Quantum 18 1.8 GHz System Amplifier features a new power supply design which accepts the standard range of input voltages. Power distribution from the SA lid is accomplished by the jumper cabling and the shunts used to route power to & through the housing are also located within a package in the lid. The red shunt indicates the input voltage side. The location of the four shunts are highlighted with the red circle. The AC and DC voltage test points are located on the front of the amplifier module next to the jumper connector from the power supply (in lid). The location of the voltage test points are highlighted in Figure 1-4.

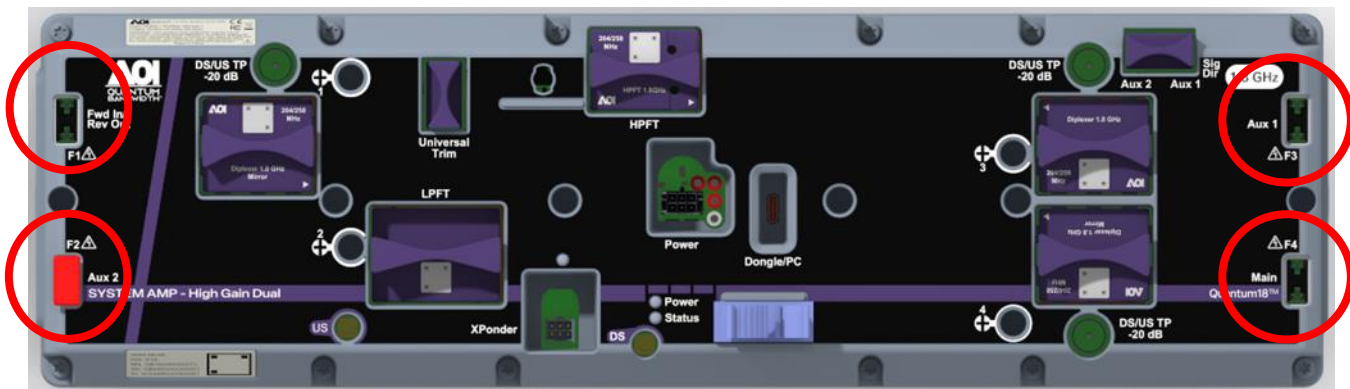

Figure 1- 5: - Shunt Point Locations

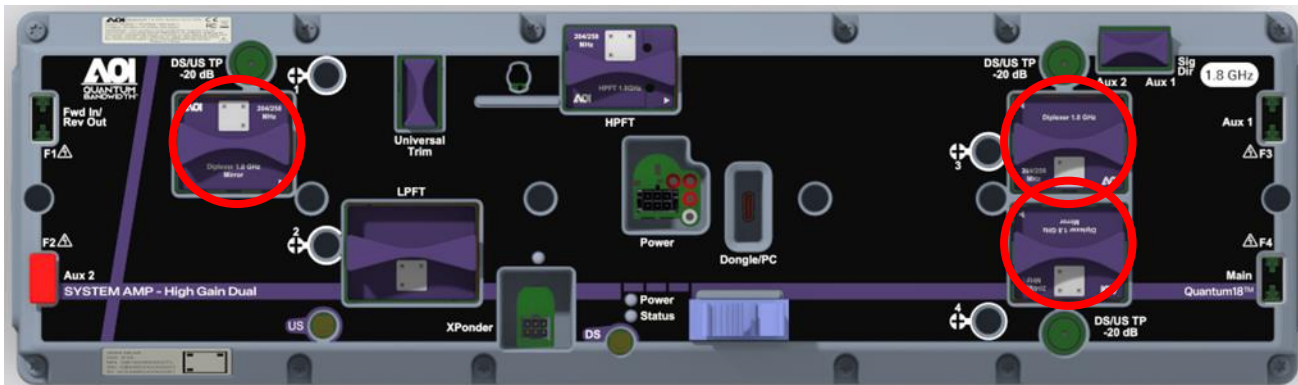

Figure 1- 6: AC/DC Test Point Locations

**ILLUSTRATIONS**

**HGD System Amplifier Accessories**

The following diagram shows the three duplex filter locations for the Quantum18 1.8GHz HGD System Amplifier.



*Figure 1- 7: HGD Duplex Filter Locations*



*Figure 1- 8: HGD QuantumLink Local Wireless Interface*



*Figure 1- 9: HGD High Pass and Low Pass Filter Trims*

Installation and Operation Guide

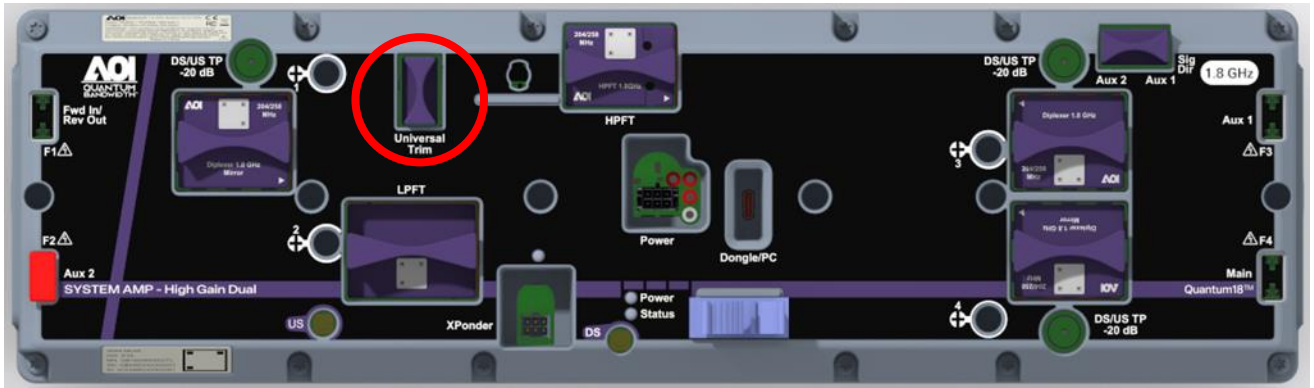
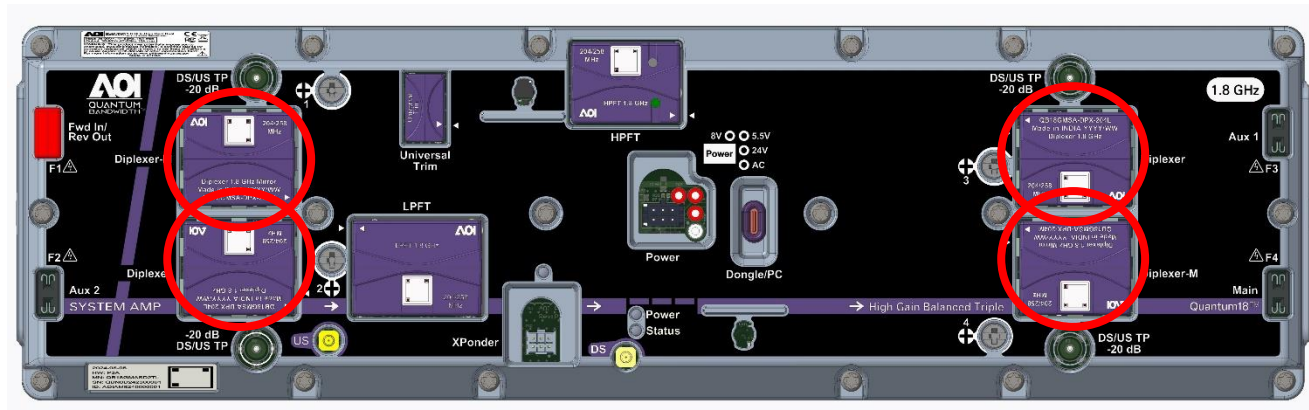

Figure 1- 10: HGD FWD Universal Trim (ships with 0dB)

**HGBT System Amplifier Accessories**

The following diagram shows the four diplex filter locations for the Quantum18 1.8GHz HGBT System Amplifier.



**Figure 1- 11: HGBT Diplex Filter Locations**

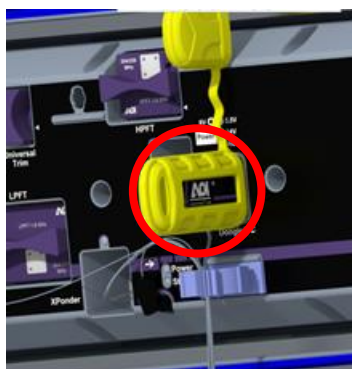

**Figure 1- 12: HGBT QuantumLink Local Wireless Interface**

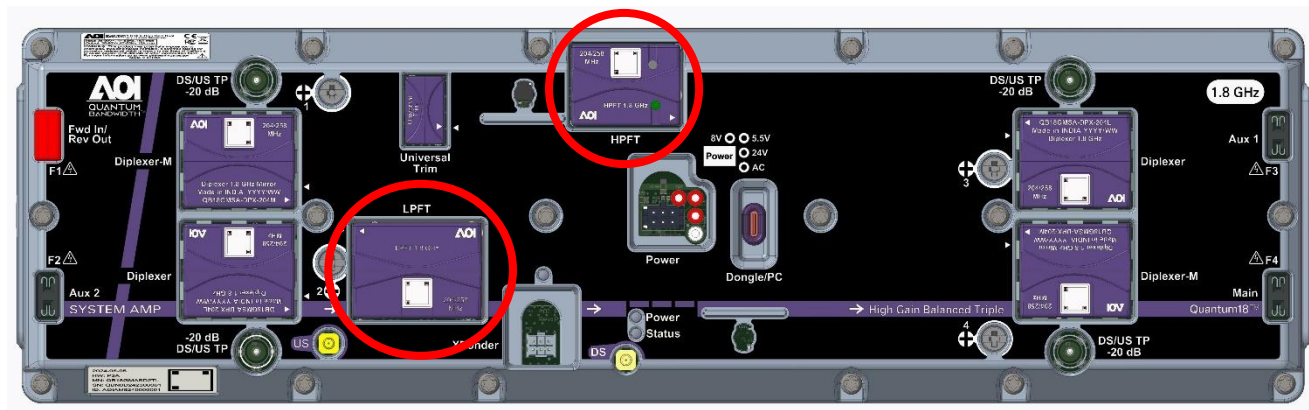

**Figure 1- 13: HGBT High Pass and Low Pass Filter Trims**

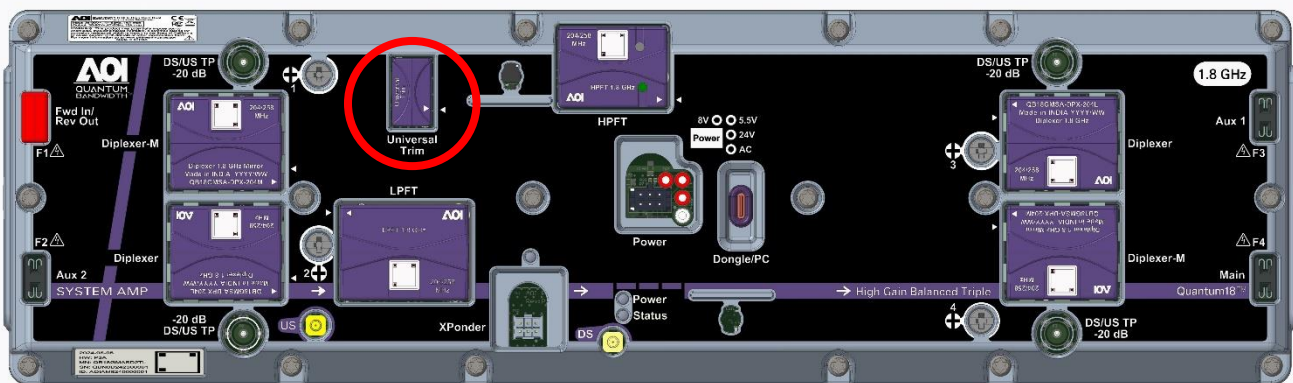

Figure 1- 14: HGBT FWD Universal Trim (ships with 0dB)

### Ordering Information

The Quantum18 1.8GHz System Amplifier is available with several forward / reverse bandwidths and user defined AGC pilot frequencies. There are also several customer selectable accessories which will be ordered separately by customers. These accessories may be ordered to complete the field set up of the System Amplifier (Diplex Filters) or spare items (power supplies, surge protectors, etc.). Please refer to the Quantum18 1.8 GHz System Amplifier Data Sheet for a full listing of accessories that are available.

**NOTE: Please consult with your Account Representative, Customer Service Representative, or System Engineer to determine the best Order for your particular application.**



Installation and Operation Guide

BLOCK DIAGRAM

The following illustration is a block diagram of the Quantum18 1.8 GHz System Amplifier module.

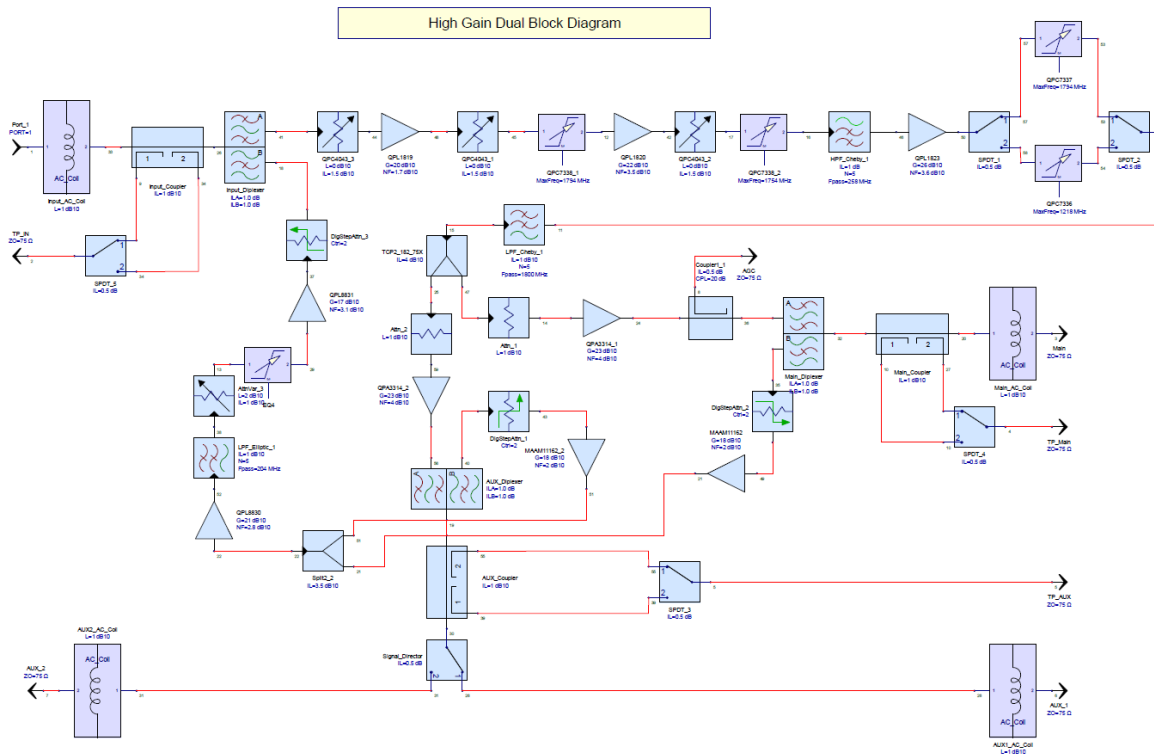

Figure 1- 15 – HGD Block Diagram

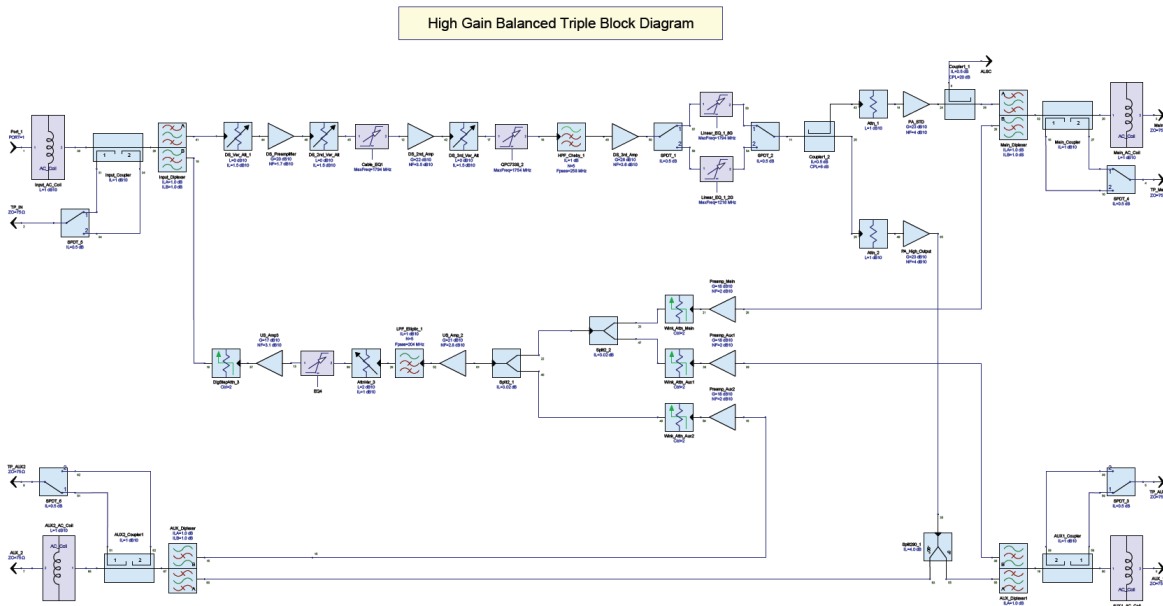

Figure 1- 16 – HGBT Block Diagram

# 2. Installation and Configuration

## In this Chapter...

OVERVIEW.....	14
BEFORE YOU BEGIN.....	15
AMPLIFIER MODULE COVER .....	17
MODULE AND HOUSING COMPATABILITY.....	17
OPENING THE SYSTEM AMPLIFIER HOUSING.....	18
UPGRADING EXISTING HOUSING SEIZURES .....	19
UPGRADING AN EXISTING HOUSING LID .....	21
INSTALLING THE POWER SUPPLY.....	23
ATTACHING THE COAXIAL CONNECTORS.....	25
INSTALLING THE HOUSING .....	27
INSTALLING ACCESSORIES .....	30
INSTALLING THE SYSTEM AMPLIFIER MODULE.....	32
REMOVING THE SYSTEM AMP MODULE FROM THE HOUSING .....	34
CLOSING THE SYSTEM AMPLIFIER HOUSING.....	35

**OVERVIEW**

This chapter provides instructions for installing and configuring the Quantum18 1.8 GHz System Amplifier in your cable system.

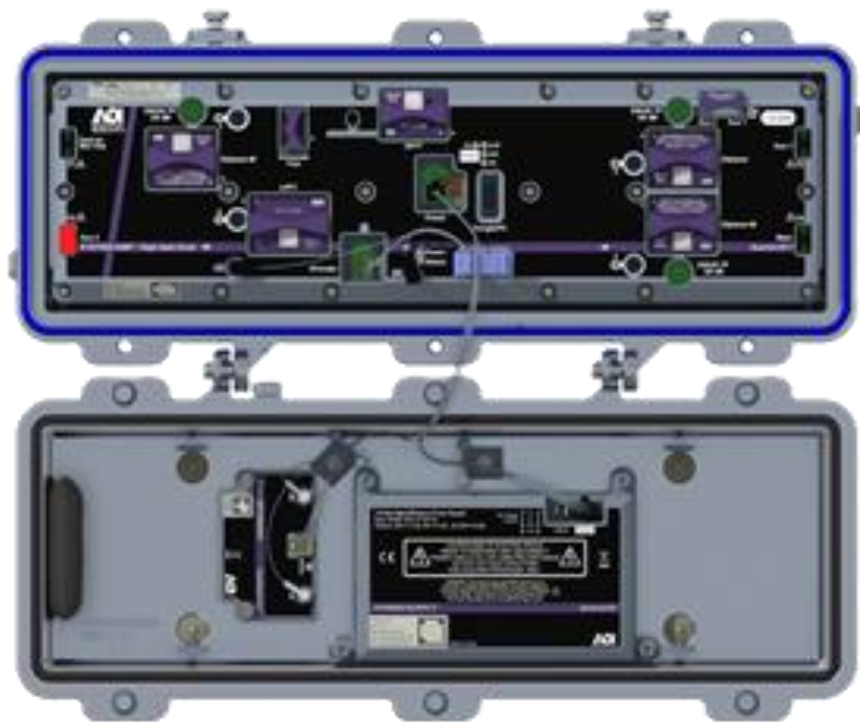

*Figure 2- 1: HGD Open Enclosure*

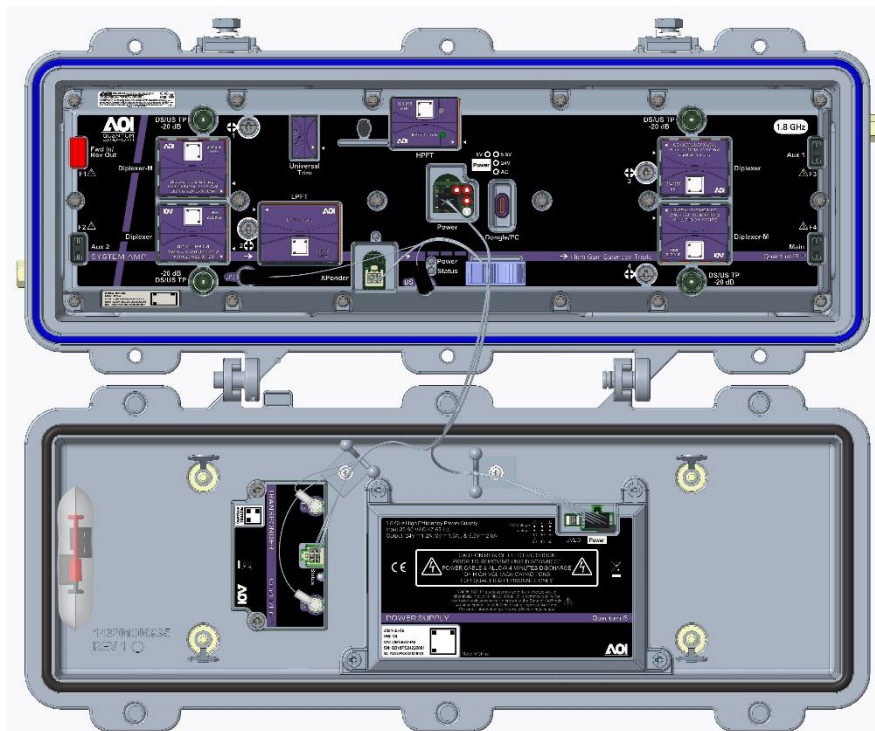

*Figure 2- 2: HGBT Open Enclosure*



*Figure 2- 3: QuantumLink Local Wireless Interface*

## BEFORE YOU BEGIN

The procedures in this chapter assume that you have completed the following:

- Prepared the installation site.
- Located and prepared the coaxial connectors mounted on the cable.
- Have the QL Local Wireless Interface and associated equipment required to Setup/Configure the Amplifier (Section 3).







## Required Equipment

Before you start, make sure that you have the following equipment:

- 1/2" wrench or nut driver.
- Torque wrench with a 1/2" socket.
- Cross-Recess head No. 2 is recommended.
- Heavy-duty wire cutters or snips.

### Torque Specifications

The following table gives the torque specifications for the module:

Fastener	Torque Specification	Illustration
<b>Transponder Module Securing Screws (Combo Head)</b>	18 in-lb to 20 in-lb (2 Nm to 2.3 Nm)	
<b>Power Supply Module Securing Screws (Combo Head)</b>	18 in-lb to 20 in-lb (2 Nm to 2.3 Nm)	
<b>Strand Clamp Mounting Bracket Bolts</b>	5 ft-lb to 8 ft-lb (6.8 Nm to 10.8 Nm)	
<b>System Amplifier Module Shoulder Screws (Combo Head)</b>	18 in-lb to 20 in-lb (2.0 Nm to 2.25 Nm)	
<b>Housing Closure Bolts</b>	10 ft-lb to 15 ft-lb (6.8 Nm to 16.3 Nm)	
<b>Test Point Port Plugs</b>	5 ft-lb to 8 ft-lb (6.8 Nm to 10.8 Nm)	

**AMPLIFIER MODULE COVER**

Quantum18 1.8 GHz System Amplifier modules have an aluminum cover attached to the chassis with self-tapping screws. Normal field maintenance will not require the removal of this cover.

**MODULE AND HOUSING COMPATABILITY**

**Housing Lid**

The Quantum18 1.8 GHz System Amplifier module is compatible with the Quantum18 System Amplifier housing lid only.

**Housing Base**

The Quantum18 1.8 GHz System Amplifier module is compatible with the Quantum12 System Amplifier housing base. Additionally, the Quantum18 1.8 GHz System Amplifier housing base is marked with a purple label to indicate that it contains 15 A capable 1.8 GHz spring-loaded seizures. Both 1.2 GHz and Quantum18 1.8 GHz System Amplifier will operate in the new Quantum18 1.8 GHz System Amplifier housing base.

**Housing Dimensions**

The diagram shows the dimensions, in inches and millimeters, of the Quantum18 1.8 GHz System Amplifier housing. Use these measurements to calculate clearance requirements for your installation

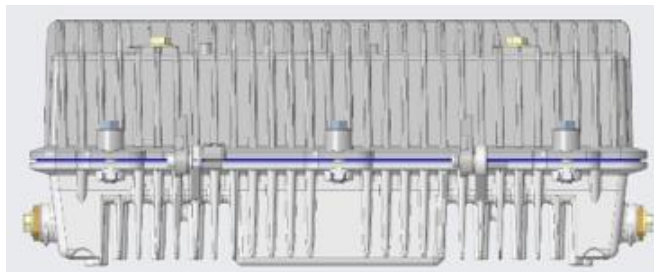

*Figure 2- 4: Closed Housing*

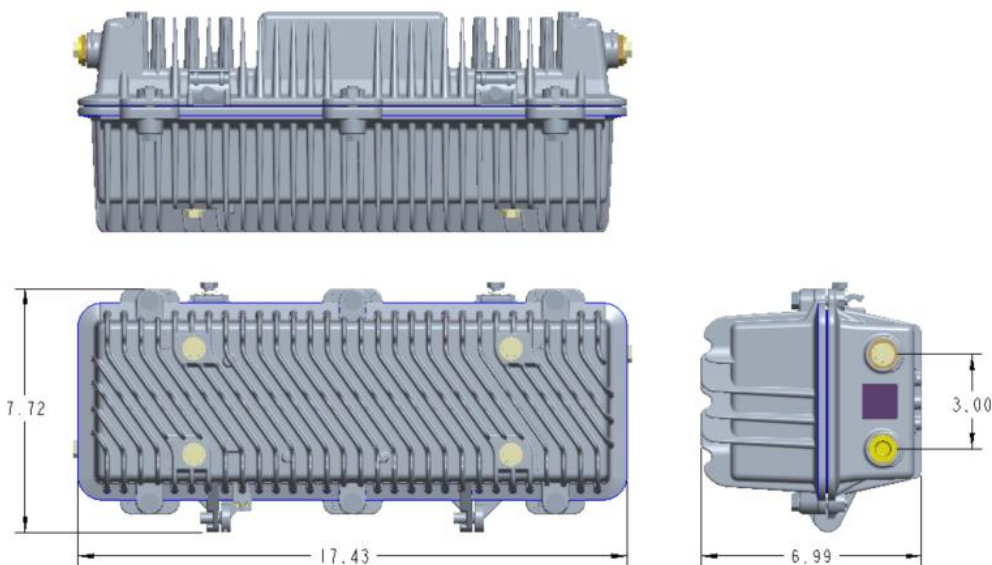
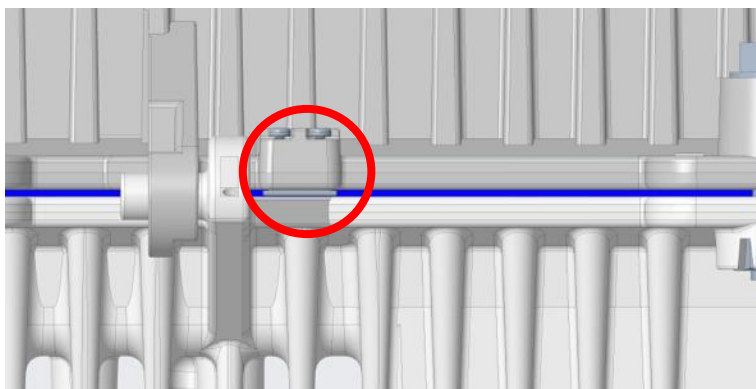

*Figure 2- 5: Enclosure Dimensions*

## OPENING THE SYSTEM AMPLIFIER HOUSING

Complete the following steps to open the System Amplifier housing.

**IMPORTANT:** Before unscrewing the housing closure bolts, make sure the Spring-Loaded Latch near the hinge is in place and secure. The latch prevents separation of the lid from the base.



**Figure 2- 6: Spring-Loaded Latch Location**

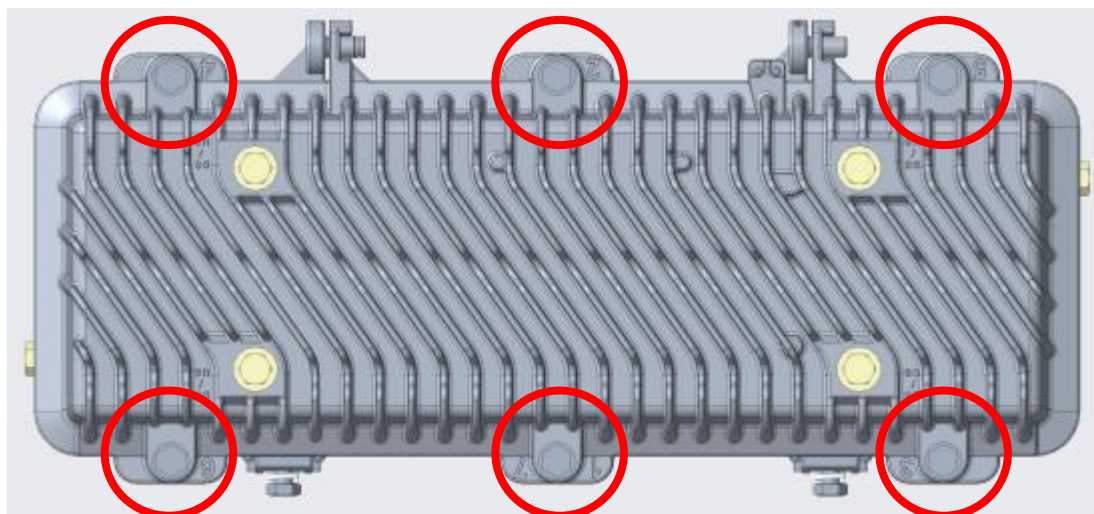

**Figure 2- 7: Housing Closure Bolts**

1. Unscrew the 1/2" Housing Closure Bolts on the housing lid until they are loose.
2. Open the housing.

**NOTE:** The closure bolts will remain attached to the housing

**UPGRADING EXISTING HOUSING SEIZURES**

The Quantum18 System Amplifier modules have a higher current-carrying capacity than some earlier amplifier module products. If you are replacing an earlier amplifier module (SA II, SA II+, or SA III) with a Quantum18 System Amplifier module, you will need to upgrade the housing base to handle the higher current demands. 15 A seizures are required with 0.063 in. diameter pins and a blue plastic material. These 15 A seizures also support higher temperatures. If they were upgraded in the past a blue label on the outside of the housing was added to indicate the seizures were upgraded. The best method is to look at the seizure and confirm the blue color plastic material is seen in the seizure.

**NOTE: The RF connectors, seizures, and anvils are coded blue for ease of identification.**



**Figure 2- 8: 15 A Blue Seizures**

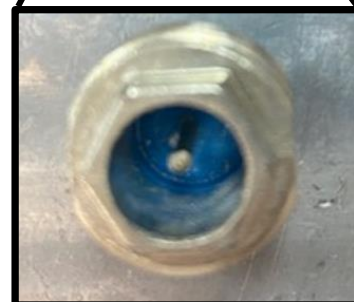



### To Install the New Housing Seizures

Complete the following steps to upgrade a system amplifier housing to 15 A current capacity.

**IMPORTANT:** *The power shunts must be removed before installing the unit into a powered housing. With shunts removed, it reduces the power surge to the components and F-connectors.*



**CAUTION:**

RF connectors and housing seizure assemblies can be damaged if AC shunt power directors are not removed from the amplifier before installing or removing the amplifier module from the housing. A red shunt indicates the input power port.

1. If an amplifier module is installed in the housing, you must remove it before continuing. Refer to “**Removing the Amplifier Module from the Housing**”.
2. Using a 1/2" nut driver, remove the seizures from the housing
3. Using a 1/2" nut driver, install the new seizure screws from the upgrade kit in the housing.
4. Do one of the following as appropriate:
  - If the coaxial cable is connected to the housing, tighten each seizure to 17 in-lb (20 kgf-cm)
  - If the coaxial cable is not connected to the housing, proceed to “**To Connect the Coaxial Cable Pin Connector to the Node Housing**”.
5. Place the purple stickers on the outside of the housing between the ports to indicate that the upgrade has been completed.

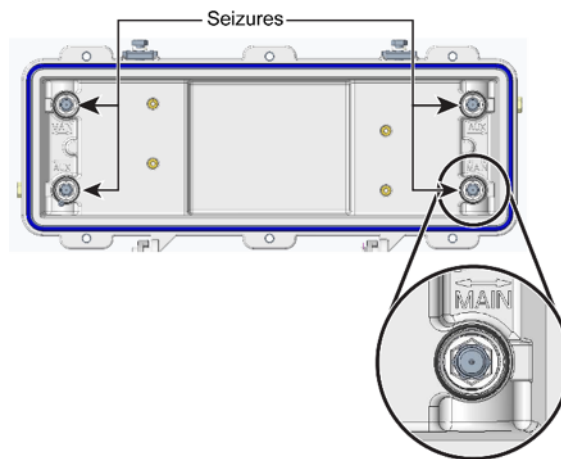

**Figure 2- 9: Seizure location**

**UPGRADING AN EXISTING HOUSING LID**

The Quantum18 System Amplifier requires a new enhanced housing lid. When replacing an earlier System Amplifier (SA II, SA II+, SA III, or GainMaker) with a Quantum18 System Amplifier, replace the existing housing lid with an updated lid, providing improved thermal design and an integrated power supply for the System Amplifier, and mounting for a Quantum Link Transponder.

**To Install the New Housing Lid**

Complete the following steps to upgrade a system amplifier housing with the newest housing lid.

	<p><b>CAUTION:</b></p> <p>RF connectors and housing seizure assemblies can be damaged if AC shunt power directors are not removed from the amplifier before installing or removing the amplifier module from the housing. A red shunt indicates the input power port.</p>
---	---

	<p><b>WARNING:</b></p> <p>Before starting this procedure in an aerial or strand mounted application, be sure to clear the area below the housing of all people, and if possible, property.</p>
---	--

	<p><b>CAUTION:</b></p> <p>In an aerial or strand mounted application, you will need to take steps to ensure that the housing lid does not fall to the ground. See the following recommended procedure.</p>
---	--

1. Use a torque wrench to loosen the housing closure bolts on the housing lid. Remove Hinge Screw if legacy housing lid.
2. Firmly grasp the housing lid and open it carefully. For legacy housing lid remove retaining screw or e-ring to enable removal of lid. If new housing lid, depress the housing lid spring load latch near the hinge. The housing lid will now swivel completely open, allowing it to be removed from the housing base.



*Figure 2- 10: Legacy Retaining Screw*

**IMPORTANT:** The enhanced lid contains a new shielding/weather-tight gasket. Inspect and clean the installed base housing gasket and all adjacent surfaces, to ensure the best possible sealing between lid and base.

Installation and Operation Guide



**WARNING:**

It is possible for the housing lid to separate from the housing base and fall, possibly causing injury or damage to persons or property below.

3. Firmly grasp the new Quantum18 housing lid, depress the housing lid spring latch, and place it onto the housing bottom, swiveling it into place on the housing hinge.

**New Housing Lid**

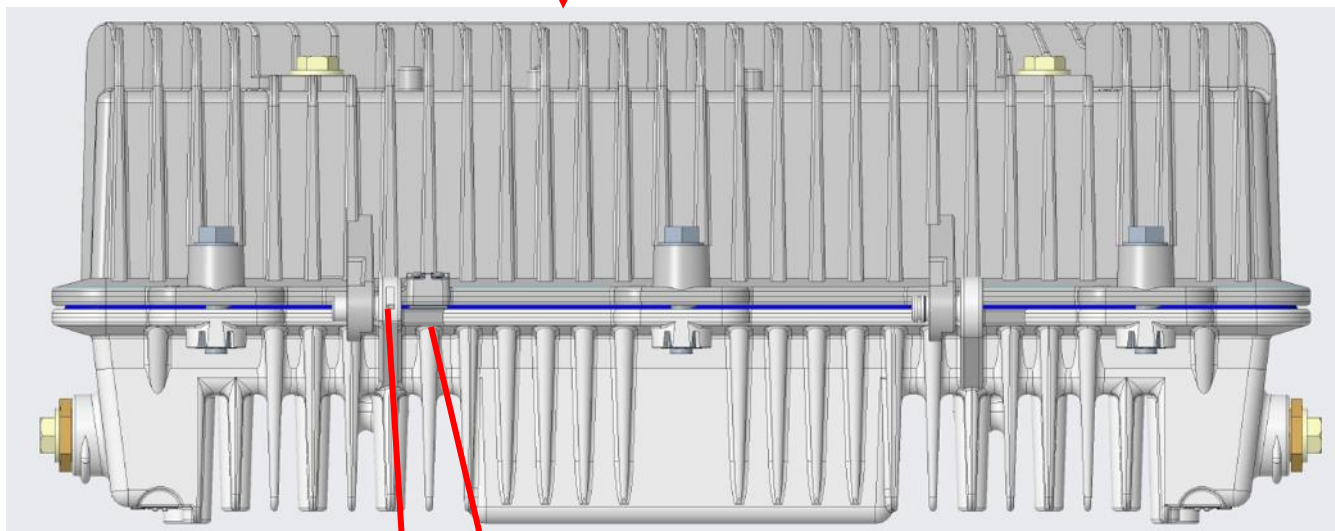

**Screw  
Removed**

**Housing Lid  
Latch**

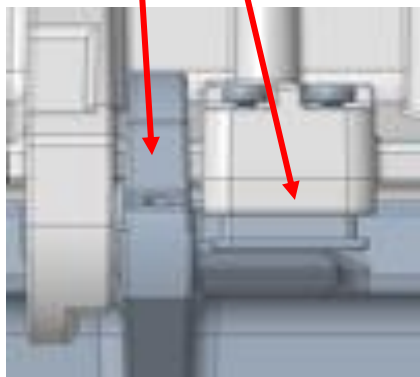

*Figure 2- 11: New Housing Lid Latch*

## INSTALLING THE POWER SUPPLY

**IMPORTANT:** The AC shunt power directors must be removed before installing the unit. Removal of the AC shunt power directors reduces the power surge to the components and F-connectors.



**CAUTION:**

RF connectors and housing seizure assemblies can be damaged if AC shunt power directors are not removed from the amplifier before installing or removing the amplifier module from the housing. A red shunt indicates the input power port.

### To Install the Power Supply Module

Complete the following steps to install the power supply module:

1. Start with the housing lid open. The power supply is installed in the housing lid.
2. Install the power supply module in the power supply cavity.

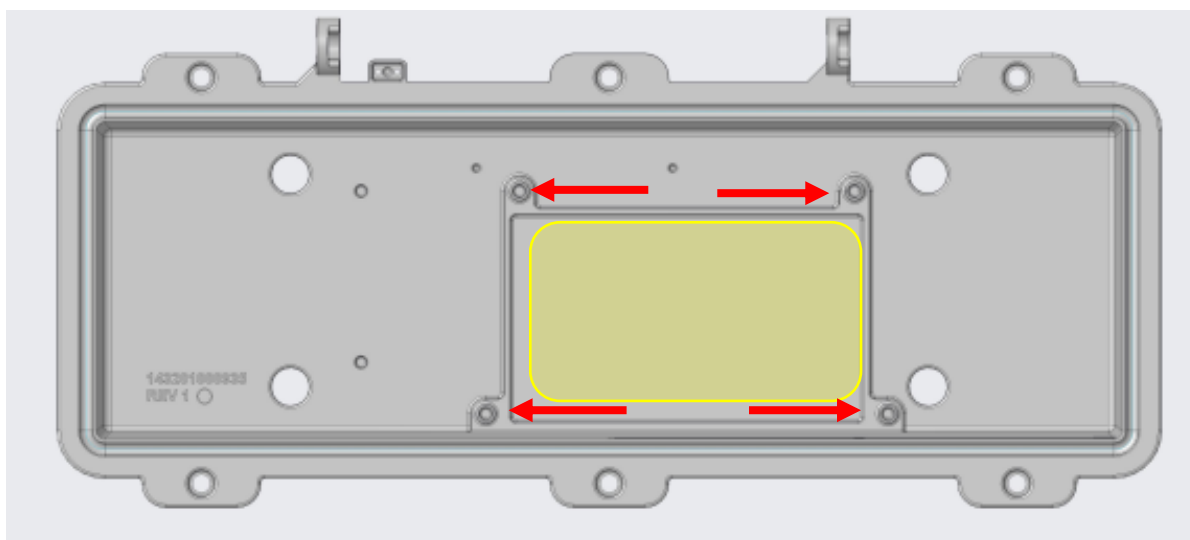

**Figure 2- 12: Installing the Power Supply**

**NOTE:** There is only one correct way to install the power supply module. Use the metal tabs as a guide to position the power supply module correctly inside the power supply cavity. Be sure that the plastic retaining tabs that secure the test point plugs to the housing lid are not pinched between the power supply and the interior of the housing lid. This will make it difficult to open the test point plug. It is important to push down on the Power Supply Assembly to ensure thermal pad is well seated.

3. Tighten the four module screws on the power supply module to 18 in-lb to 20 in-lb (2.0 Nm to 2.3 Nm). Torque the screws in the following sequence – bottom left, bottom right, top left, top right.

Installation and Operation Guide

- Attach the 8-pin keyed connector of the power cable and harness to the power supply module.

**NOTE: The 8-pin keyed connector can be connected one way only. Be sure that the connector is installed securely to the power supply module connector.**

- Proceed to “To Set the AC Undervoltage Lockout Selector”.

**To Set the AC Undervoltage Lockout Selector**

Set the AC undervoltage lockout selector for your application as specified by your system engineering guidelines.

Undervoltage Lockout Setting	Application
30 V Lockout	60 VAC System
40 V Lockout	90 VAC System
50 V Lockout	90 VAC System

Complete the following steps to set the AC undervoltage lockout selector.

- Locate the AC undervoltage lockout selector on the power supply in the housing lid.
- Set the AC undervoltage lockout jumper for your application as illustrated in the following diagram.

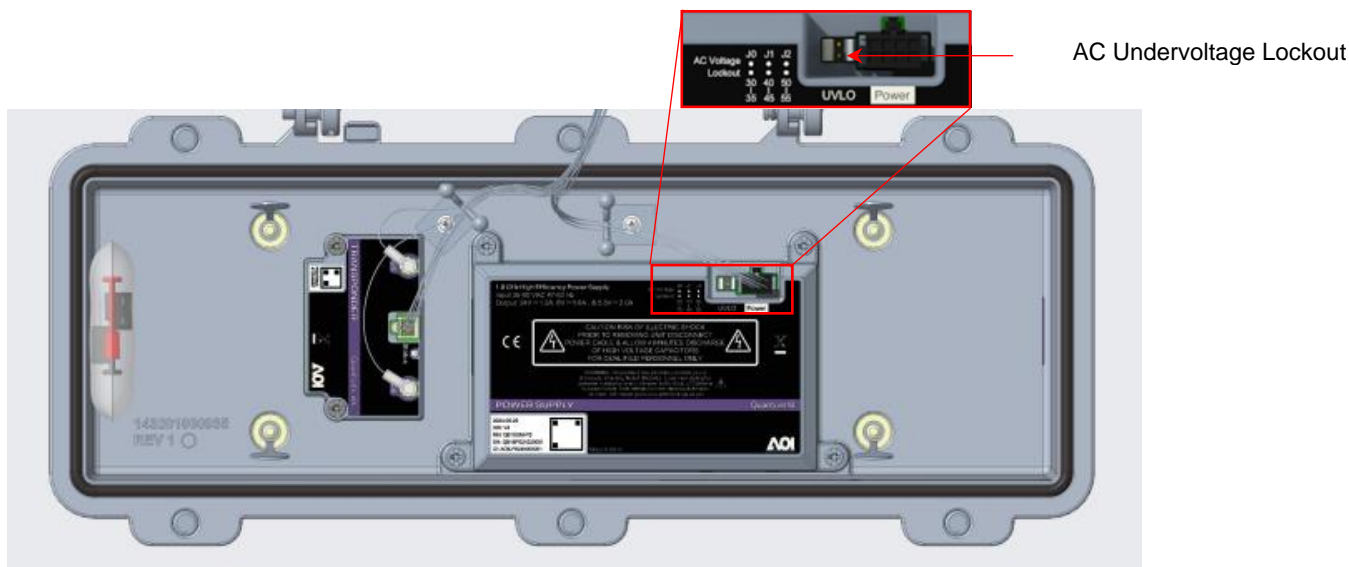

**Figure 2- 13: AC Undervoltage Lockout Selector**

**NOTE: The AC undervoltage lockout selector positions are also noted on the power supply**

- Proceed to “Attaching the Coaxial Connectors”.

## ATTACHING THE COAXIAL CONNECTORS

### To Trim the Center Conductor

The Quantum18 1.8 GHz System Amplifier requires pin-type connectors for all RF connections. Standard pin connectors, with pins extending 1.55 in. to 1.6 in from the connector shoulder. The longer length allows for the pin to engage the internal spring-loaded contact before the connector threads engage the housing. This reduces the required insertion force when working to engage the connector threads. It may also help to twist the connector back and forth slightly while pressing in against the seizure to get the tip of the pin to engage.

**IMPORTANT: Do not allow the pin to exceed the 1.6-inch maximum length. We also recommend the cut tip of the pin connector be filed smooth to remove any metal burrs.**

Complete the following steps to trim long pins:

1. Place the connector in one of the 4 “cradles” so that it lines up with the “cut” line.
2. Trim the pin at the small Arrow above the word “cut”.

The following diagram shows a visual guide of the center conductor trim length.

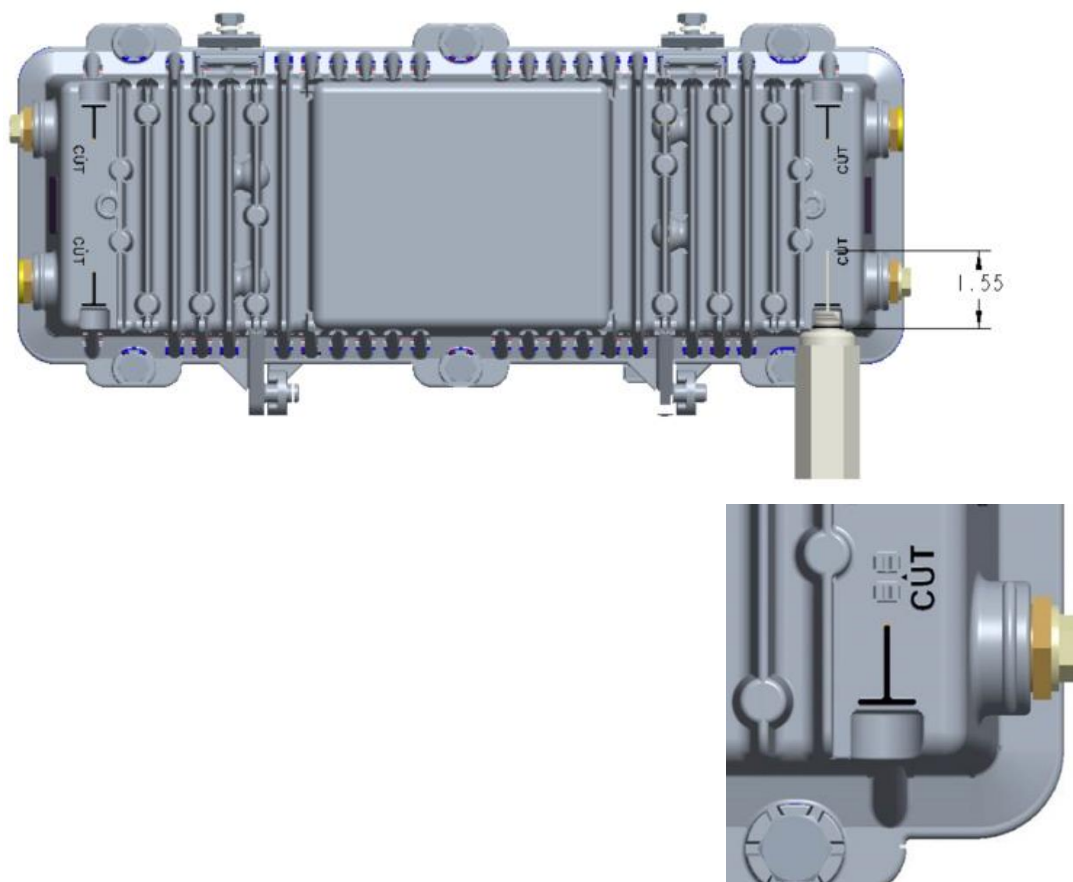

Figure 2- 14: Coaxial Cut Length

### To Connect the Coaxial Cable Pin Connector to the System Amplifier Housing

Complete the following steps to connect the coaxial cable pin connector to the Quantum18 1.8 GHz System Amplifier housing:

1. Begin this procedure with the System Amplifier housing open. Refer to “To Open the System Amplifier Housing”.
2. If the coaxial cable connector center pin extends more than the length specified in “To Trim the Center Conductor”, trim the pin with heavy-duty wire cutters.
3. Insert the appropriate coaxial connector into the housing at the desired housing port. Tighten the connector nut according to manufacturer specifications.
4. Tighten the coaxial cable connector to housing entry port to 20 – 25 ft-lb (27 – 33.9 N-m).
5. Tighten the seizure screw to 17 in-lb (20 kgf-cm).
6. Repeat steps 2 through 5 for the other RF ports.
7. Proceed to “Installing the Housing”.

**INSTALLING THE HOUSING**

The following procedures detail how to install the Quantum18 1.8 GHz System Amplifier housing on a strand (aerial) or in a pedestal.

**To Install the Housing on a Strand (Aerial)**

Complete the following steps to install the housing on a strand (aerial). The housing does not need to be opened for strand installation.

**IMPORTANT:** *The minimum strand diameter should be 5/16”.*

	<p><b>CAUTION:</b></p> <p>Be aware of the size and weight of the housing while strand mounting.</p> <p>Ensure that the strand can safely support the weight of the housing.</p>
---	---

1. Loosen the strand clamp bolts.
2. Lift the housing into proper position on the strand.
3. Slip the strand clamps over the strand and finger-tighten the clamp bolts. This allows additional movement of the housing as needed.
4. Move the housing as needed to install the coaxial cable and connectors. See the diagrams below for examples.
5. Ensure proper grounding of the housing meets industry standards and local code requirements (NESC, etc.)

**Signal Flow From Left to Right**

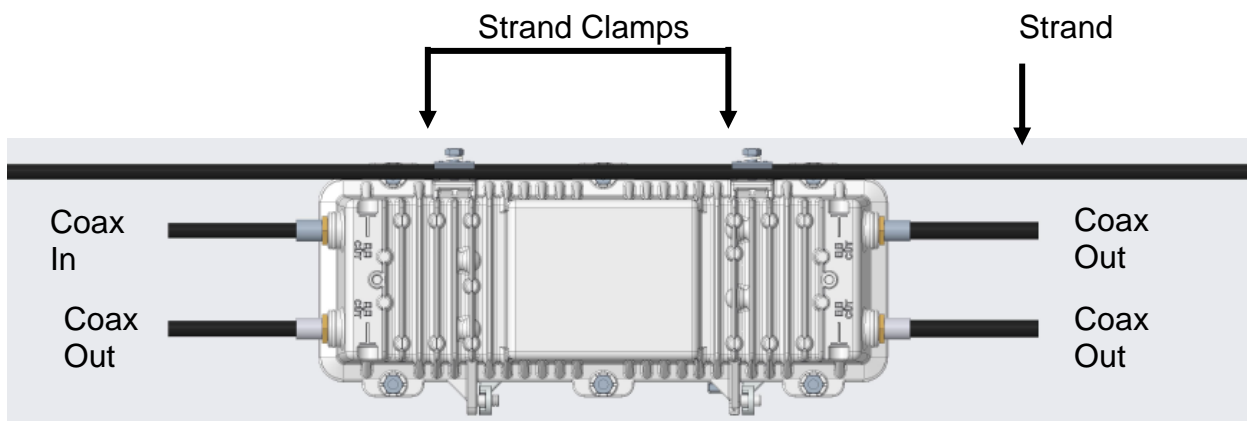

**Figure 2- 15: Signal Flow From Left to Right**

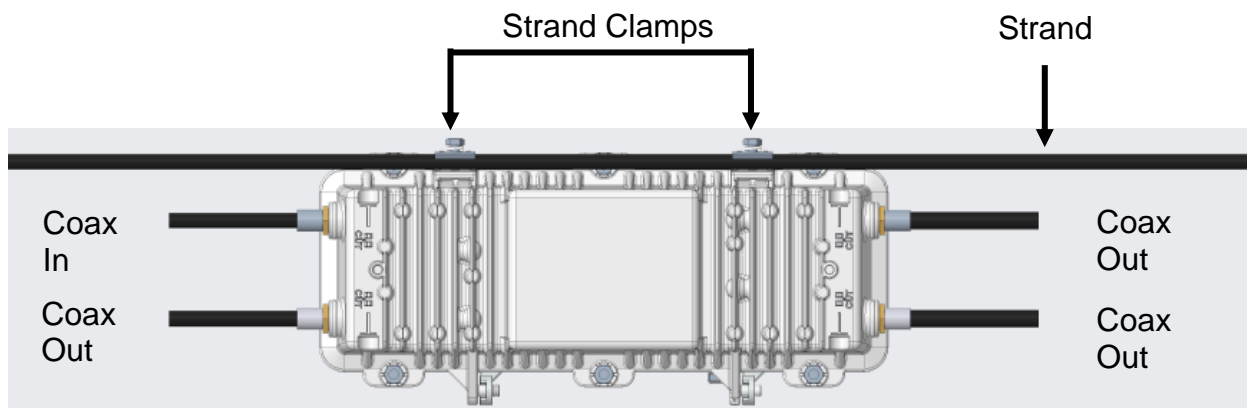

**Signal Flow From Right to Left****Figure 2- 16: Signal Flow From Right to Left**

**NOTE: Coax In may be switched with the Coax Out if you reverse the system amplifier module and feed the signal from right to left.**

6. Using a 1/2" torque wrench, tighten the strand clamp bolts from 5 ft-lb to 8 ft-lb (6.8 Nm to 10.8 Nm). Make sure there is good mechanical contact between the strand and the housing.

**NOTE: A slight tilt of the face of the housing is normal. Cable tension will cause the housing to hang more closely to vertical.**

7. Connect the coaxial cable to the pin connector according to connector manufacturer specifications.
8. Proceed to "Installing the System Amplifier Module"

### To Install the Housing in a Pedestal

Complete the following steps to install the system amplifier in a pedestal:

1. Remove the cover of the pedestal.
2. Remove the self-tapping bolts from the strand clamps and set the bolts and strand clamps aside.
3. Position the housing in the pedestal frame as shown in the following illustration. Line up the self-tapping bolt holes on the bottom of the housing with the mounting holes on the bracket.

**NOTE:** *The housing mounts to the bracket provided by the pedestal manufacturer.*

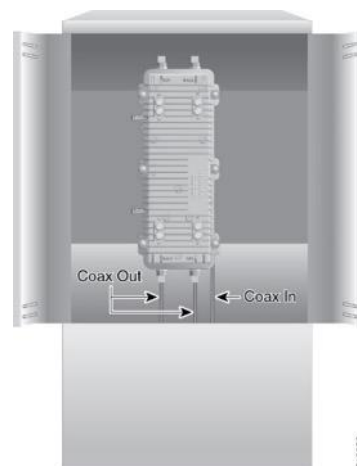

**Figure 2- 17: Pedestal Installation**

4. Secure the housing to the bracket by using the bolts that you removed in Step 2. Use the strand clamps as spacers if necessary. Ensure proper grounding of the housing meets industry standards and local code requirements (NESC, etc.)
5. Torque the bolts from 8 ft-lb to 10 ft-lb (10.8 Nm to 13.6 Nm).
6. Connect the coaxial cable to the pin connector according to connector manufacturer specifications.
7. Proceed to “**Installing the System Amplifier Module**”.

**INSTALLING ACCESSORIES**

**To Install the Plug-in Signal Director (High Gain Dual Only)**

Complete the following steps to install the signal director in the amplifier:

1. Begin this procedure with the housing open. Refer to “Opening the System Amplifier Housing”.

**NOTE: This accessory can be installed without removing the amplifier cover.**

2. Choose the correct signal director for your system as specified by the design print.

If you are Installing a....	This will...
Jumper	activate only one auxiliary port
Splitter	activate both auxiliary ports with equal signal levels
8 dB Coupler, 10 dB Coupler or 12 dB Coupler	activate both auxiliary ports with differing signal levels

**IMPORTANT: Be sure that the signal director is oriented in the proper direction for your system. Rotating the signal director in the slot will change which ports are activated by which signal. Refer to the following table to determine the orientation appropriate for your system installation.**

**NOTE: Be sure all pins on the signal director bottom align with the pin holes in the signal director slot, allowing the signal director to install flat against the amplifier module.**

**Jumpers**

To activate the....	Orient the jumper...
Aux 1 Port	so that the word “Thru” on the jumper label is next to the word “AUX 1” on the amplifier module cover.
Aux 2 Port	so that the word “Thru” on the jumper label is next to the word “AUX 2” on the amplifier module cover.

**Splitter**

To activate the....	Orient the jumper...
Aux 1 Port and Aux 2 Port	so that the word “AUX 1” on the jumper label is next to the word “AUX 1” on the amplifier module cover, and so that the word “AUX 2” on the jumper label is next to the word “AUX 2” on the amplifier module cover. <b>IMPORTANT: Do NOT reverse the splitter and the signal director slot as this could degrade the amplifier signal.</b>

Installation and Operation Guide

**8 dB Coupler**

To activate the....	Orient the jumper...
Aux 1 Port with the 8 dB “Tap Leg” Signal and Aux 2 Port with a “Thru Leg” Signal	so that the “8” on the jumper label is next to the word “AUX 1” on the amplifier module cover, and so that the word “Thru” on the jumper label is next to the word “AUX 2” on the amplified module cover.
Aux 2 Port with the 8 dB “Tap Leg” Signal and Aux 1 Port with the “Thru Leg” Signal	so that the “8” on the jumper label is next to the word “AUX 2” on the amplifier module cover, and so that the word “Thru” on the jumper label is next to the word “AUX 1” on the amplified module cover.

**10 dB Coupler**

To activate the....	Orient the jumper...
Aux 1 Port with the 10 dB “Tap Leg” Signal and Aux 2 Port with a “Thru Leg” Signal	so that the “10” on the jumper label is next to the word “AUX 1” on the amplifier module cover, and so that the word “Thru” on the jumper label is next to the word “AUX 2” on the amplified module cover.
Aux 2 Port with the 10 dB “Tap Leg” Signal and Aux 1 Port with the “Thru Leg” Signal	so that the “10” on the jumper label is next to the word “AUX 2” on the amplifier module cover, and so that the word “Thru” on the jumper label is next to the word “AUX 1” on the amplified module cover.

**12 dB Coupler**

To activate the....	Orient the jumper...
Aux 1 Port with the 12 dB “Tap Leg” Signal and Aux 2 Port with a “Thru Leg” Signal	so that the “12” on the jumper label is next to the word “AUX 1” on the amplifier module cover, and so that the word “Thru” on the jumper label is next to the word “AUX 2” on the amplified module cover.
Aux 2 Port with the 12 dB “Tap Leg” Signal and Aux 1 Port with the “Thru Leg” Signal	so that the “12” on the jumper label is next to the word “AUX 2” on the amplifier module cover, and so that the word “Thru” on the jumper label is next to the word “AUX 1” on the amplified module cover.

3. Install other options or accessories as desired or proceed to “**Installing the System Amplifier Module**”.

## INSTALLING THE SYSTEM AMPLIFIER MODULE

The System Amplifier module plugs into the strand-mounted or pedestal-mounted (bottom) of the housing via RF connectors on the bottom side of the module.

System Amplifier housings and System Amplifier modules are designed so that you can orient the module conveniently for maintenance. Because the input and main output ports are located diagonally across from each other, the System Amplifier module is reversible. This allows you to orient all System Amplifier housings to open either to the roadside or to the field side. The System Amplifier is then installed in the appropriate position, either right side up or upside down.

### To Install the System Amplifier Module

Complete the following steps to install the system amplifier module:

1. Perform the following if you are working with the system amplifier where AC is present.



#### CAUTION:

RF connectors and housing seizure assemblies can be damaged if shunts are not removed from the system amplifier before installing or removing the system amplifier module from the housing. A **red** shunt indicates the input power port.

- Install the AC shunt power directors in the amplifier **after** you install the amplifier module in the housing.
  - Remove the AC shunt power directors from the amplifier **before** you remove the amplifier module from the housing.
2. Orient the system amplifier module so the **Input** and **Main** output ports (the locations of which are stamped on the module cover) are in the proper corners for your installation.
  3. Line up the RF connectors on the system amplifier module and the housing, and then push the system amplifier module into the housing.

Installation and Operation Guide

- Secure the System Amplifier module to the housing by tightening the four System Amplifier module retainer screws. Tighten combo head screws to 18 in-lb to 20 in-lb (2.0 Nm to 2.25 Nm). See the following illustration for the location of the retainer screws (circled in red in Figure 2.17 below).

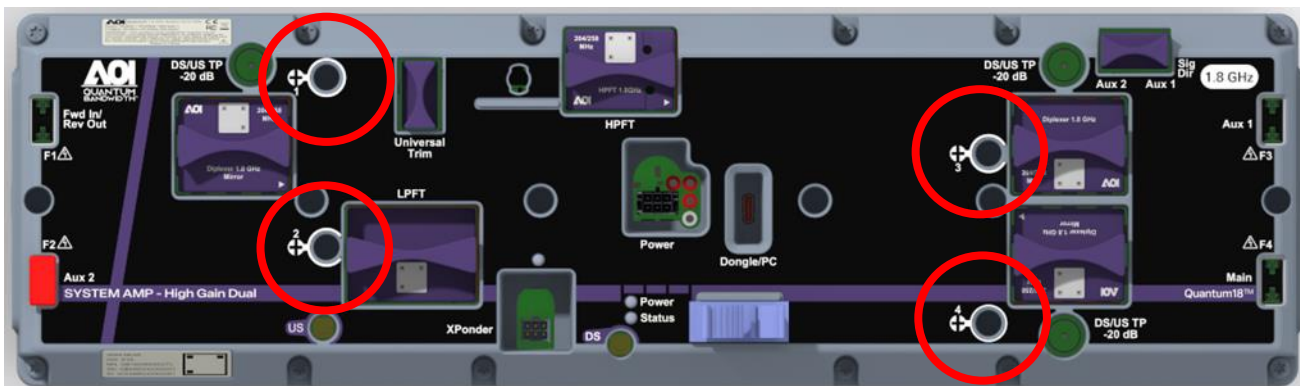

Figure 2- 18: Screw Locations

- Snap the power cable harness into place in the holes provided.
- Attach the 6-pin keyed connector of the power cable and harness to the system amplifier module.

**NOTE: The 6-pin connector can be connected one way only. Confirm that the connector installs securely to the System Amplifier module.**

- Install the shunts (locations circled in red) into the sockets to route the AC into and through the module to downstream active devices. They are in a plastic pocket attached to the System Amplifier cover. A red shunt indicates the input power port.

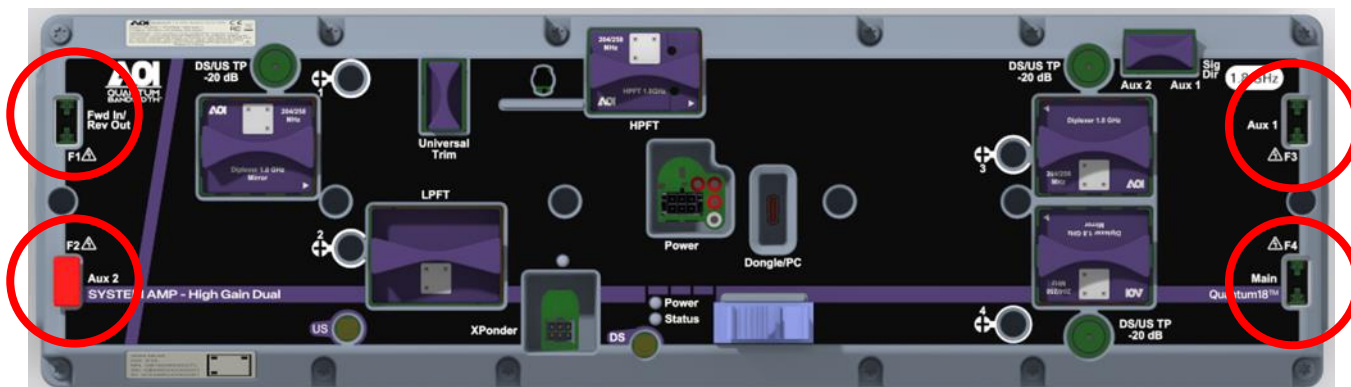

Figure 2- 19 - Shunt Locations

## REMOVING THE SYSTEM AMP MODULE FROM THE HOUSING

### To Remove the System Amplifier Module

Complete the following steps to remove the system amplifier module:

1. Open the housing. Refer to “**To Open the System Amplifier Housing**”.
2. Remove the AC shunt power directors from the amplifier before you remove the amplifier module from the housing. A red shunt indicates the input power port.
3. Unplug the 6-pin keyed connector of the power cable harness from the System Amplifier module.
4. Remove the power cable harness from the white plastic retainer clip.
5. Using a cross-recess driver No. 2, loosen the two module retaining screws.
6. Remove the system amplifier module from its housing and place the system amplifier module on a secure surface

**CAUTION:**

Avoid personal injury and damage to the system amplifier module. Make sure that you place the system amplifier module on a secure surface.

## CLOSING THE SYSTEM AMPLIFIER HOUSING

### To close the System Amplifier Housing

Complete the following steps to close the system amplifier housing:



**CAUTION:**

Avoid moisture damage and RF leakage! Follow the procedure exactly as shown below to ensure a proper seal.

1. Inspect the housing gasket and all mating surfaces. Wipe off any excess dirt and debris.
2. Close the housing and finger-tighten all housing closure bolts.
3. Use a torque wrench with a 1/2" socket to tighten each closure bolt from 10 ft-lb to 15 ft-lb (13.6 Nm to 20.3 Nm) each.
4. The tightening sequence is shown in the following **Torquing Sequence** section. Follow the numbered sequence to tighten the housing closure bolts.

### Torquing Sequence

The following diagram shows the proper torquing sequence for the housing closure bolts.

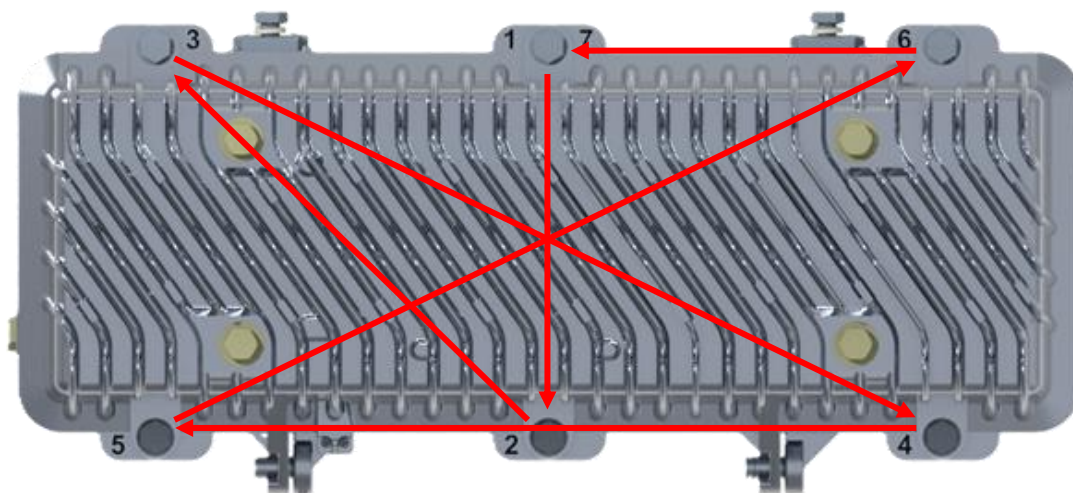

*Figure 2- 20: Torquing Sequence*



# 3. Balancing and Setup

In this Chapter...

INTRODUCTION .....	37
PREPARING FOR AMPLIFIER SET-UP.....	38
VERIFY/UPDATE AMPLIFIER INFORMATION .....	40
VERIFY/UPDATE AMPLIFIER CONFIGURATION.....	41
LOCATION DATA .....	42
DOWNSTREAM PROFILE CONFIGURATION.....	43
DOWNSTREAM AUTO ALIGNMENT .....	44
DOWNSTREAM MANUAL ALIGNMENT.....	45
VIEW DOWNSTREAM SPECTRUM .....	46
UPSTREAM ALIGNMENT .....	47
UPSTREAM ALIGNMENT...continued.....	48
CASCADE ALSC ACTIVATION .....	49
TEST POINTS .....	50
DIAGNOSTICS.....	51

**INTRODUCTION**

This section provides instructions for the initial setup and balancing methods for both the Quantum18 1.8 GHz HGD and HGBT System Amplifier. The process is the same for both, the description below shows the HGD. Troubleshooting and Diagnostics is also covered.

During the initial install, the steps outlined will provide steps to identify the Quantum18 1.8 GHz System amplifier and its location in the network. Following steps will focus on the downstream and upstream initial setup using an auto-alignment or manual process. During the auto-alignment process the steps will allow the amplifier to automatically adjust itself to provide unity gain within the RF design of the network, the Quantum18 1.8 GHz System Amplifier is being installed. This is achieved without the need of field level measurements, that are typically required during an RF network setup.

The technician will establish a Bluetooth connection to the amplifier to perform the activations process via the QuantumLink Local Wireless Interface that is plugged into the Quantum18 1.8 GHz System amplifier module. All Quantum18 1.8 GHz System Amplifier are expected to have identical RF output levels with the varying RF inputs electronically adjusted for optimal performance. There is no field-level adjustment of levels (downstream & upstream) once the initial installation process is completed.

These procedures are performed once the amplifier has been spliced into the outside plant in accordance with the system operator’s typical field practices. An Android or iOS device is used to establish a Bluetooth connection with the QuantumLink Local Wireless Interface plugged into the Quantum18 1.8 GHz System Amplifier module (shown below).

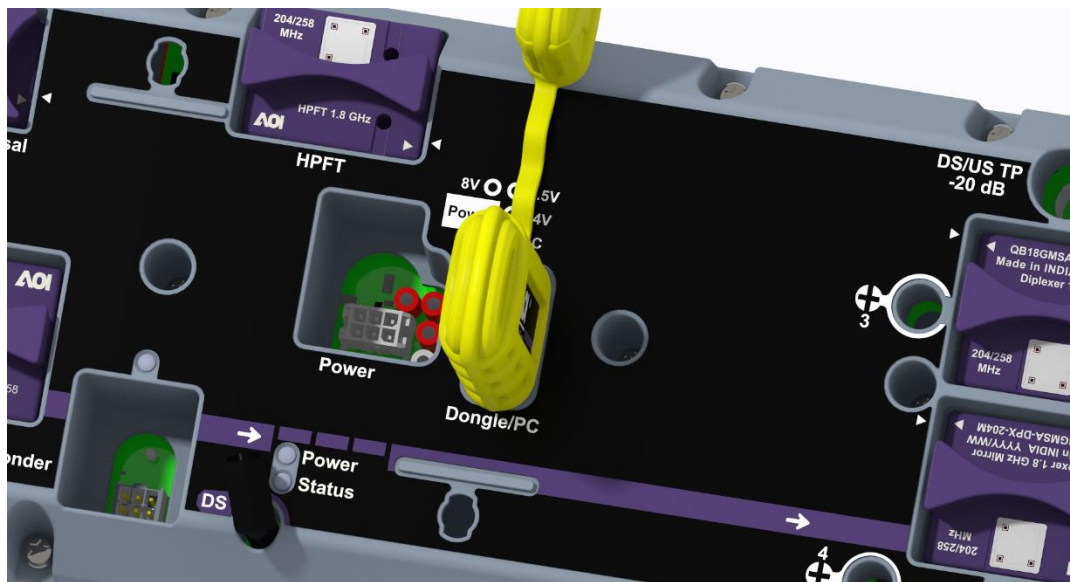

**Figure 3- 1: QuantumLink Local Wireless Interface installed in a SA**

**PREPARING FOR AMPLIFIER SET-UP**

- Locate and Initiate QuantumLink Local Mobile Application on the Technician’s portable device (Tablet/Handheld), see Figure 3-2.
- Insert the QuantumLink Local Wireless Interface in the Quantum18 1.8 GHz System Amplifier, amplifier module as shown above, see Figure 3-1.
- Establish point to point connections via Bluetooth between the technician’s portable device and the QuantumLink Local Wireless Interface by using “Select Device” drop down in the QuantumLink Local Mobile Application menu to select the proper QuantumLink Local Wireless Interface, see Figure 3-3.
- Log into the QuantumLink Local Mobile Application, using an accepted username and password, see Figure 3-4.

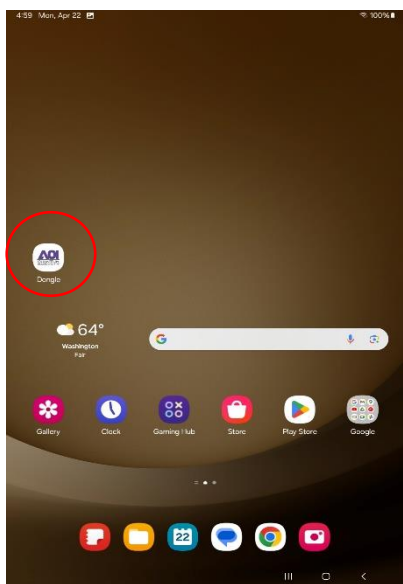

**Figure 3- 2: Home Screen**

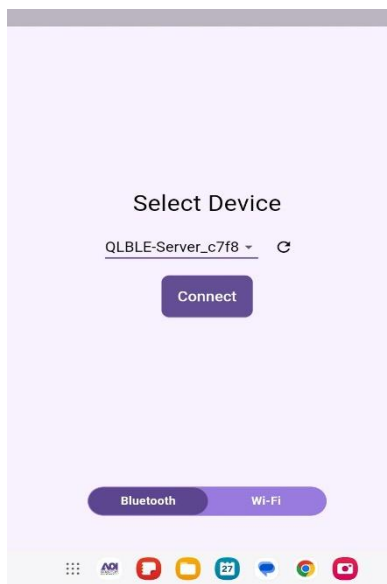

**Figure 3- 3: Device Selection**

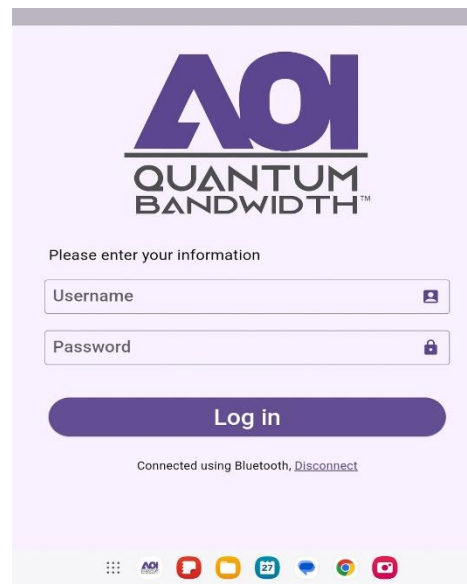

**Figure 3- 4: User Login**

**VERIFY LATEST FIRMWARE AND MAC ADDRESS**

- From the Main Menu located in the top left section of the QuantumLink Local Mobile Application, select the menu, then select “About”. Figure 3-5.
- A new screen appears showing the present version of the QuantumLink Local Wireless Interface firmware, the QuantumLink Local Mobile Application. Version, and the QuantumLink Local Wireless Interface Mac Address. Figure 3-6.

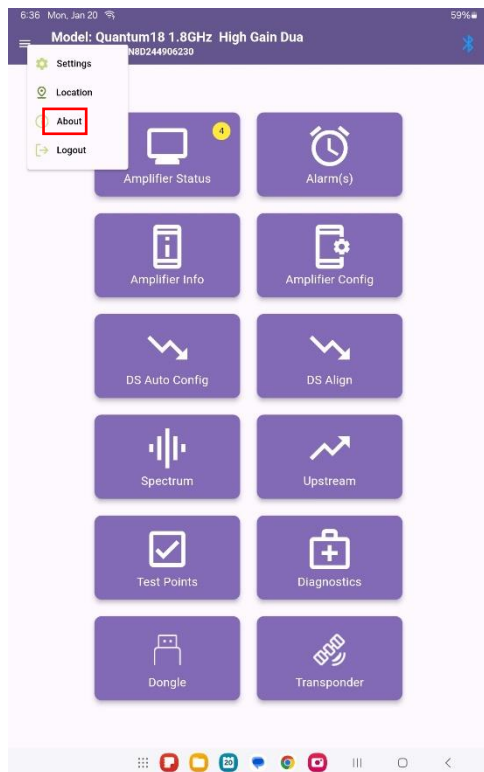

**Figure 3- 5: Main Menu**



**Figure 3- 6: About Information**

**VERIFY/UPDATE AMPLIFIER INFORMATION**

- Select the “Amplifier Info Tile” to obtain the data specific to this Amplifier. Figure 3-7.
- See below for Amplifier Info available. Device Alias and Device Description are not initially populated, to update, select and update to a desired Alias and Device Description. Select return to main menu.

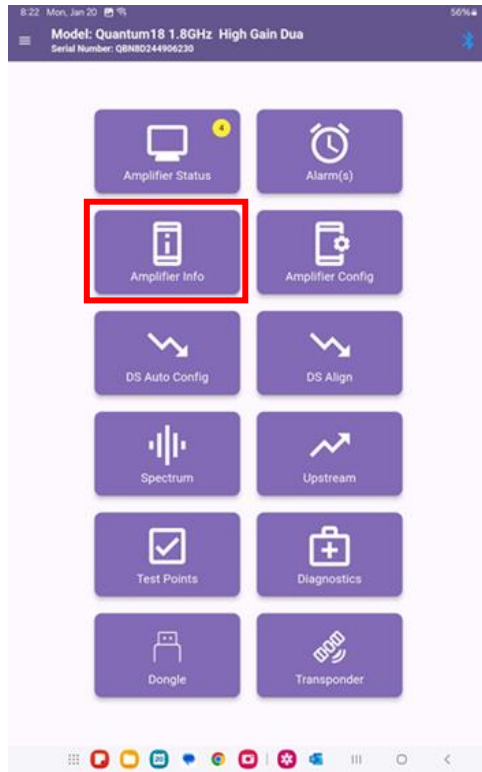

**Figure 3- 7: Amplifier Info Tile**

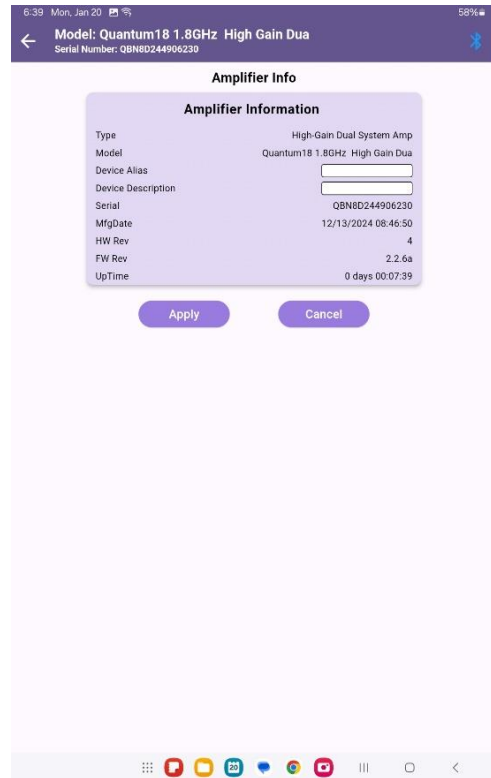

**Figure 3- 8: Amplifier Info Details**

**VERIFY/UPDATE AMPLIFIER CONFIGURATION**

- Select the Amplifier Config Tile Figure 3-5.:
  - Diplex Filter – Verify correct frequency split is displayed. If not select proper frequency split from frequency split drop down.
  - ALSC – Is default selected to “OFF”. To turn on, select “ON”. The active selection is darker in appearance.
  - Operational Mode – Is default to 1.8GHz. To change to 1.2GHz, select the “1.2GHz”.
  - The active bank is indicated with a green check mark, signifying the memory location for the amplifier’s active firmware version. If an update to the amplifier firmware is necessary, the "Update" option should be used. Refer to the Amplifier Firmware Update procedure for detailed instructions.

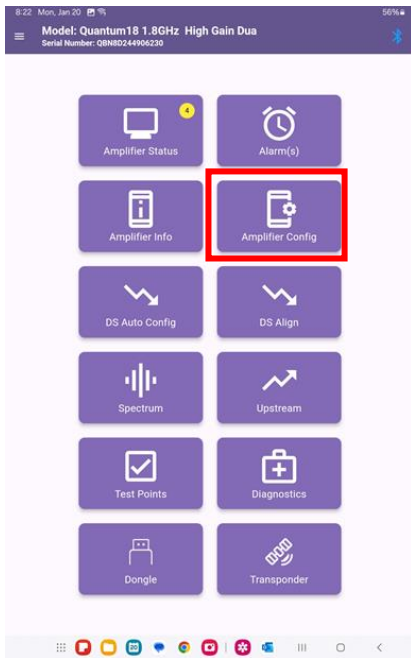

**Figure 3- 9: Amplifier Configuration Tile**

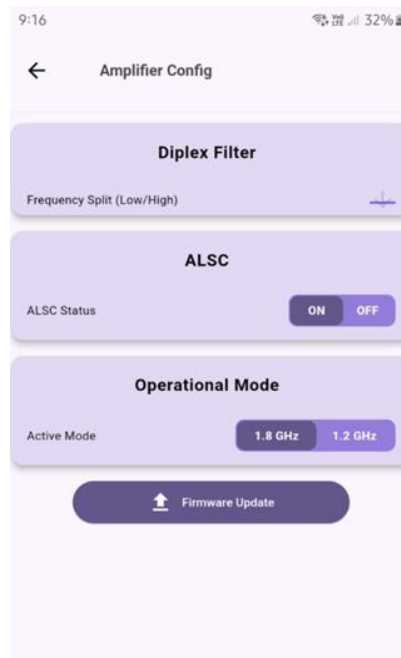

**Figure 3- 10: Amplifier Configuration Details**

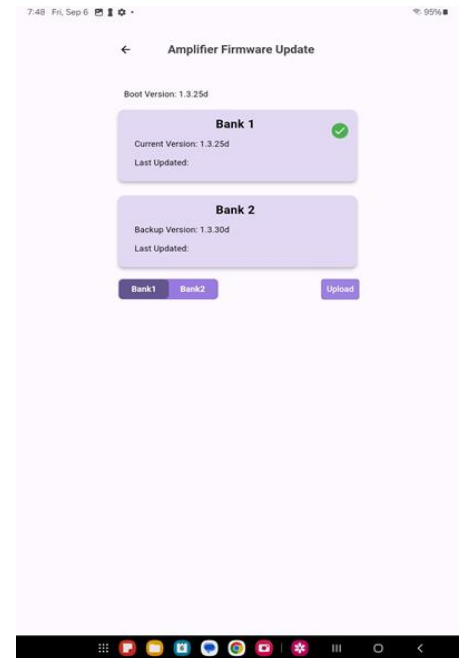

**Figure 3- 11: Amplifier Firmware Update**

**LOCATION DATA**

The specific geo-location of the device is either manually or automatically written into the device’s memory. The portable device’s GPS coordinates, Google Maps, and manual Long/Lat entry are available options.

- To automatically set the geo-location with a portable device, select the location icon from the drop-down menu of the Home screen. Figure 3-12.
- Next select, Edit location at the bottom of the screen. Figure 3-13.
- Finally select, the “My Location” icon on the screen and then press save location afterwards. Figure 3-14.

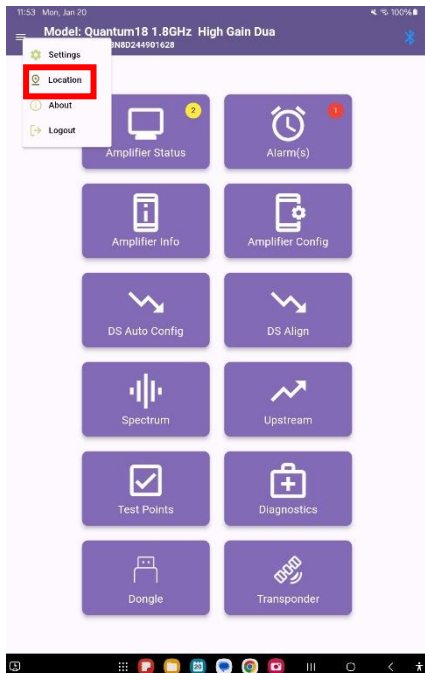

Figure 3- 13: Location Menu

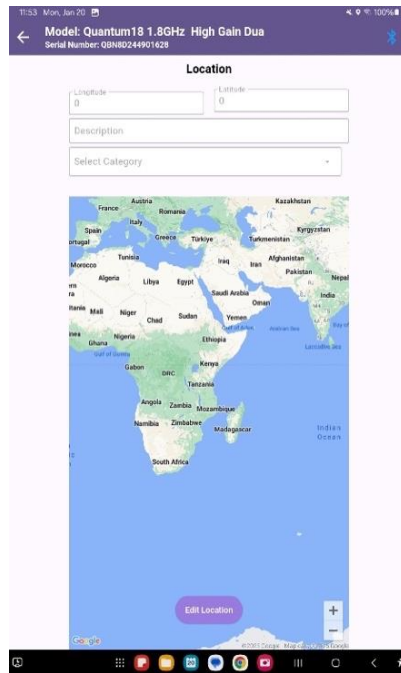

Figure 3- 14: Edit Location

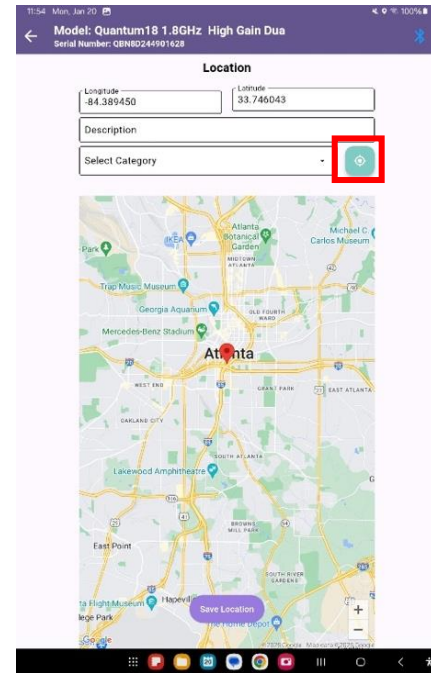

Figure 3- 12: Set Location

### DOWNSTREAM PROFILE CONFIGURATION

Select DS Auto Config Tile from the Main Menu. Figure 3-15.

The default factory Downstream Configuration Parameters are displayed here.

- Auto Config – Update frequency settings and power levels as defined for this Amplifier’s Profile
- ALSC – No action required, for information only
- Auto Align Marker Pilots – No action required, for information only

After updates are made select Apply to save changes to the Amplifiers settings. Figure 3-16.

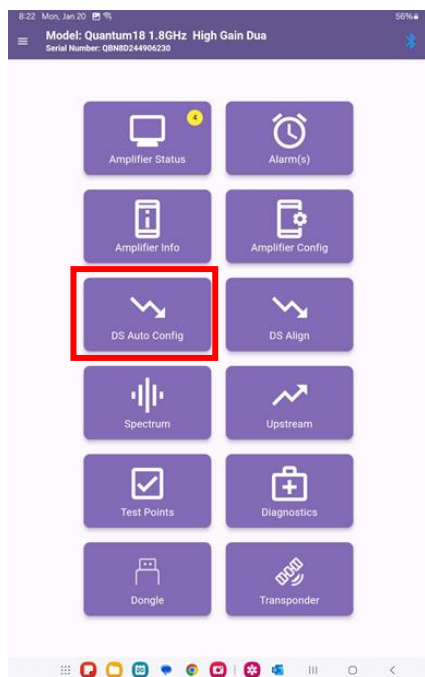

Figure 3- 15: DS Auto Config Tile

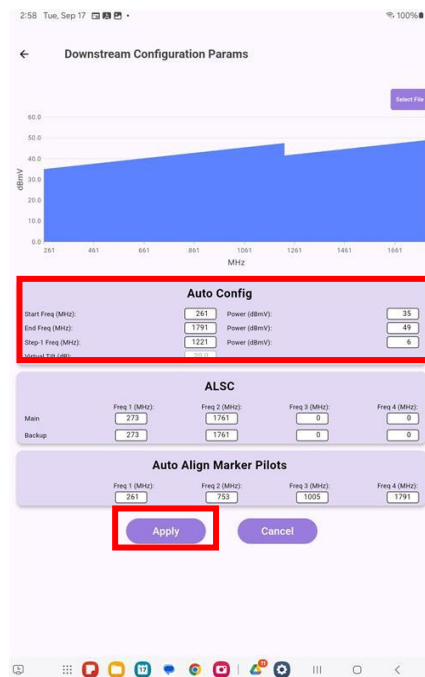

Figure 3- 16: Auto Config Details and Apply



### DOWNSTREAM AUTO ALIGNMENT

The Downstream (DS) auto-alignment is performed after the pilot carrier frequencies are confirmed and properly stored in the amplifier, during the Downstream Profile Configuration section. Figure 3-17.

- Select DS Align Tile from the Main Menu
- Select Auto and then select Start Downstream Alignment to begin Auto Alignment. Figure 3-18.

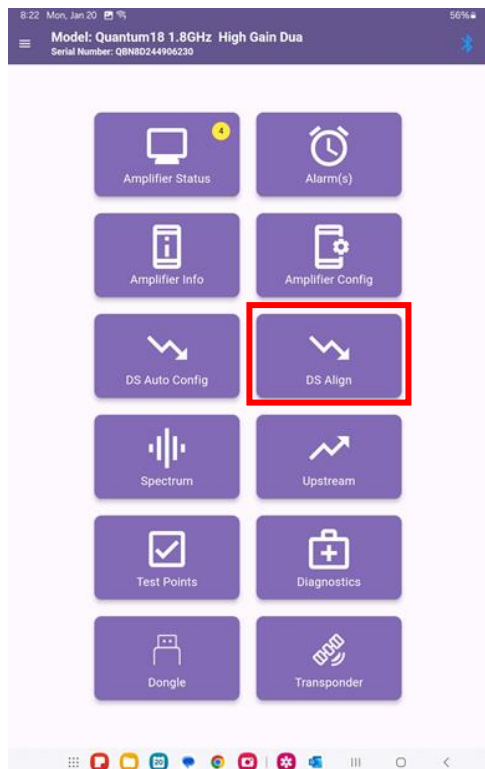

Figure 3- 17: DS Align Tile



Figure 3- 18: Auto Alignment Button

### DOWNSTREAM MANUAL ALIGNMENT

The Downstream (DS) manual alignment must be performed after an Auto-alignment has been completed. The technician reviews how relative changes are made by dynamically changing the Pilot Frequency Power Levels. This process is described below. ***This is typically not required under normal field operational conditions.***



1. Select Manual
2. Adjust the different values one at a time to verify the Level Marker frequency levels match the Ref. Marker frequency levels.
3. The check box to the right of the +/- is pressed to apply the changes but are not saved.
4. After pressing the check box and selecting the Save Configuration are the changes saved to the amplifier.
5. Should the results be undesirable, simply press the "Revert" key to return to factory pre-set which will allow DS-Auto Align to override Manual activity.

Figure 3- 19: Downstream Alignment

**VIEW DOWNSTREAM SPECTRUM**

The Spectrum Tile, Figure 3-20, is selected to verify the downstream RF configuration has been successfully completed. This process requires approximately 30 seconds to scan the output downstream RF response.

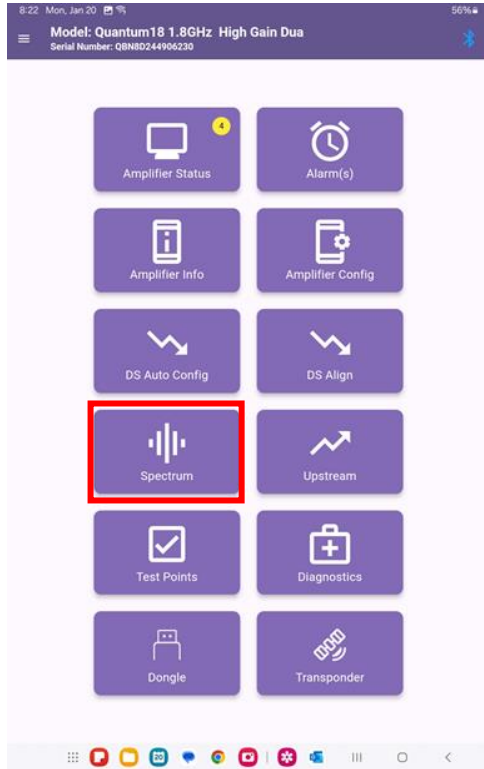

**Figure 3- 20: Spectrum Tile**

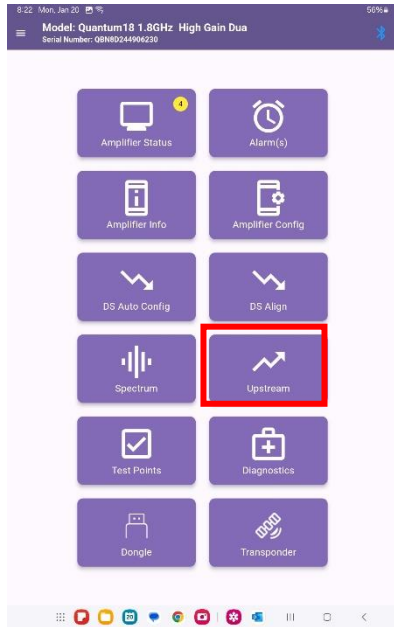

**Figure 3- 21: Spectrum Capture**

**UPSTREAM ALIGNMENT**

Upon completion of the Downstream setup and balancing for a cascade of amplifiers, the Upstream alignment must begin with the last amplifier in the cascade. Upstream alignment can be performed in Auto or Manual modes.

- Select the Upstream Tile – Figure 3-22.
- For Auto Alignment - Select Start Auto. Figure 3-23.
- After Auto Alignment is successfully completed a pop-up window appears requesting to Save or Revert (redo) the alignment.



**Figure 3- 22: Upstream Tile**

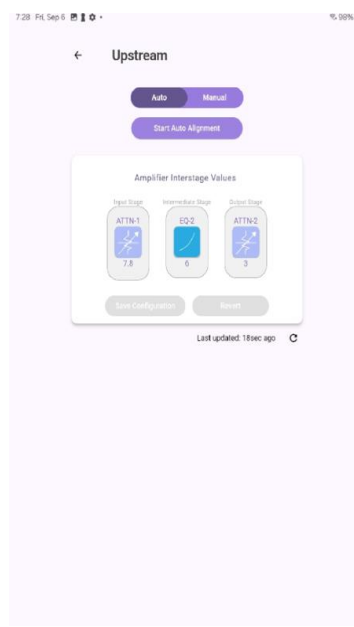

**Figure 3- 23: Auto Alignment**

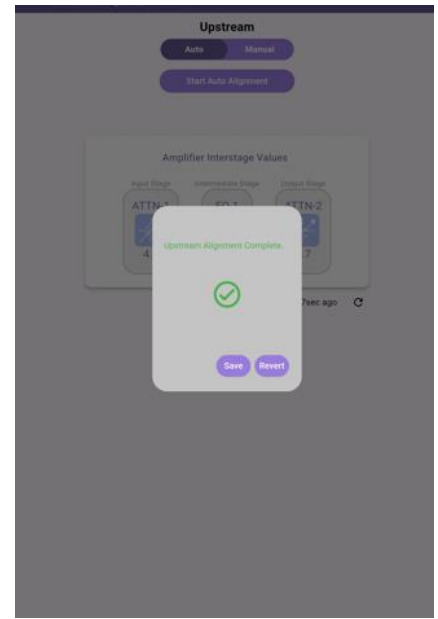
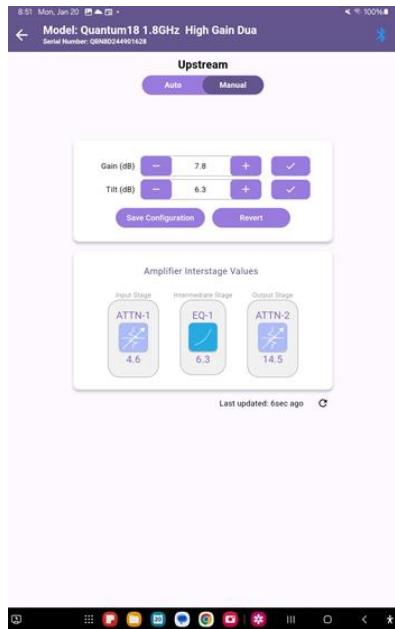

**Figure 3- 24: Alignment Complete**

**UPSTREAM ALIGNMENT...continued**

- For Manual Alignment-Select Manual: Figure 3-25. A Viavi “ONX-630” meter is required. The Viavi meter, in the DOCSIS Expert mode, will be used as the US alignment measurement tool. Initiate the US alignment procedure to force the US to adhere to the levels required for the desired network operation.

**IMPORTANT: Failure to correct the US levels could result in partial Node outages by driving the US levels to be either too high or too low.**



**Figure 3- 25: Upstream Alignment**

1. Select Manual
2. Adjust the Gain and Tilt one at a time to check the marker frequency levels.
3. The check box to the right of the +/- is pressed to apply the changes but are not saved.
4. After pressing the check box and selecting the Save Configuration all the changes are saved to the amp.
5. Should the results be undesirable, simply press the “Revert” key to return to factory pre-set which will allow US-Auto Align to override Manual activity.

Viavi DOCSIS Expert US-Settings		
F-Center	Type	RF Level
17.5	TDMA	38.0
24	TDMA	38.0
30.4	TDMA	38.0
36.8	TDMA	38.0

**Table: Example of US settings for 750MHz**

**CASCADE ALSC ACTIVATION**

Upon completion of both Downstream and Upstream Alignment, Enable ALSC for each amplifier:

- At main menu select Amplifier Config – Figure 3-26.
- At Amplifier Config Select ALSC to the ON position – Figure 3-27.
- Repeat for All Amplifiers in Cascade

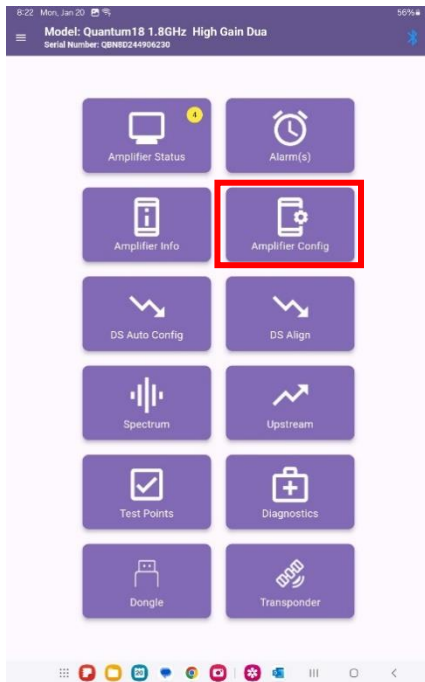

**Figure 3- 27: Amplifier Config Tile**

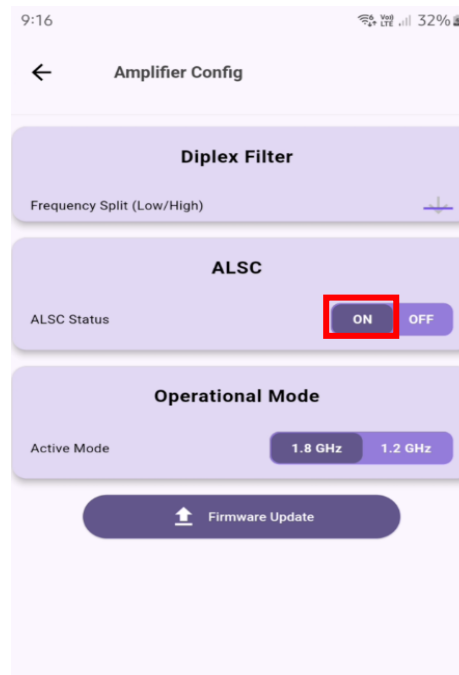
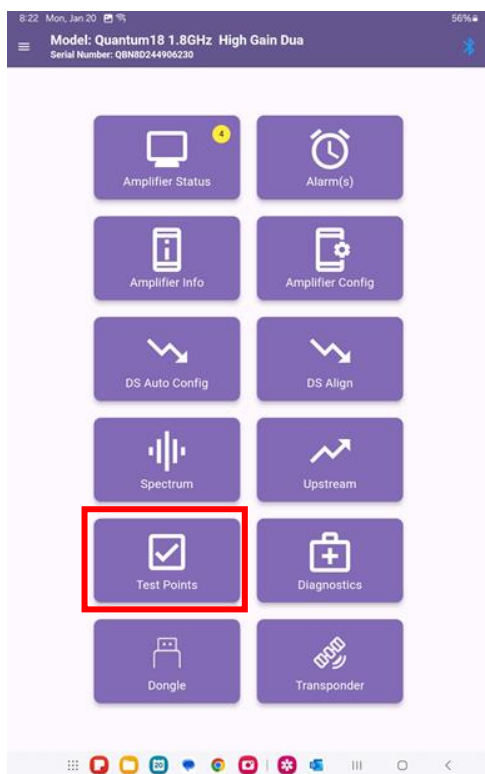

**Figure 3- 26: ALSC Status**

**TEST POINTS**

Configuring Test Points for Measurement in the Downstream and the Upstream.

- At main menu select Test Points Tile – Figure 3-28.
- Select Test Point Operation – Figure 3-29.
  - Main FWDIN – Select either FWD IN or REV OUT to measure the desired upstream signal or downstream signal
  - Main FWDOUT – Select either FWD OUT or REV IN to measure the desired upstream signal or downstream signal
  - Aux FWDOUT – Selecting either FWD OUT or Rev IN to measure the desired upstream signal or downstream signal



**Figure 3- 28: Test Points Tile**

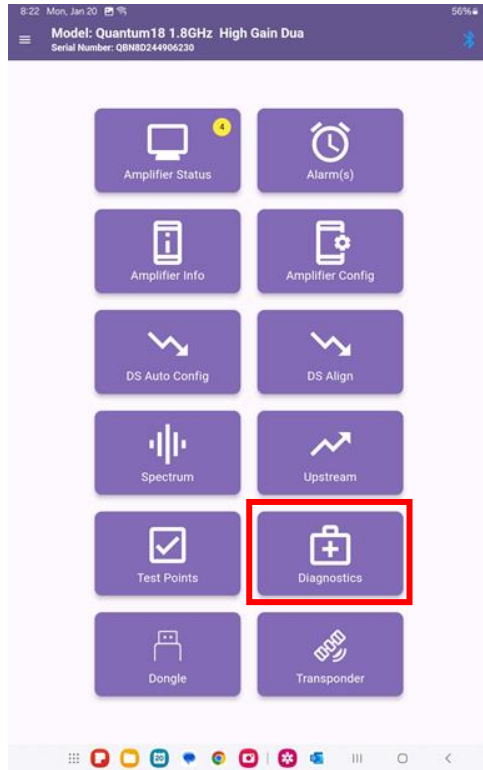

**Figure 3- 29: Test Point Status**

**DIAGNOSTICS**

The ingress switch can be used to attenuate the US signals by a variable amount.

- At main menu select Diagnostics Tile – Figure 3-31.
- In the Diagnostics Mode – Figure 32. The Ingress Switch for either the Main output port or AUX 1 and Aux 2 ports can be selected to one of three Positions
  1. Off – 0 dB for normal operation
  2. 6 dB of attenuation is commonly used to isolate the coaxial spans before the US amplifier to isolate the ingress point(s) - SNR degradation
  3. Max ~ 30 dB of attenuation



**Figure 3- 30: Diagnostics Tile**

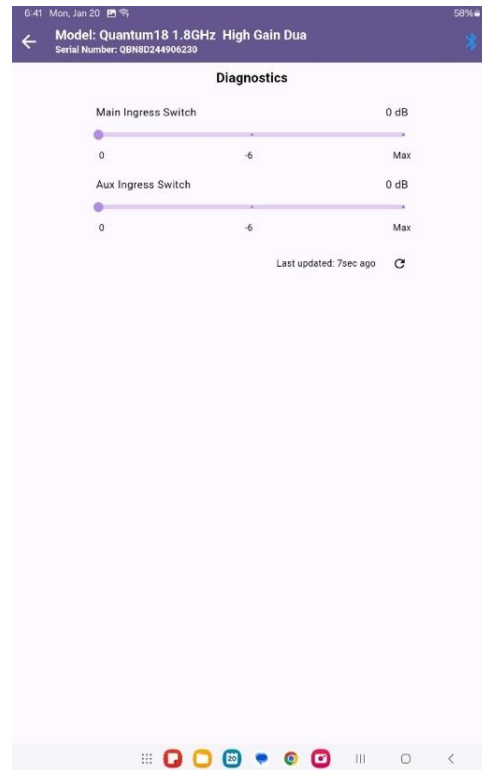

**Figure 3- 31: Diagnostics Information**



# 4. TROUBLESHOOTING

## In this Chapter...

INTRODUCTION .....	53
NO AC POWER .....	54
NO DC POWER .....	56
NO DC POWER TROUBLE SHOOTING TABLE .....	56
NO FORWARD RF SIGNAL .....	57
LOW OR DEGRADED FORWARD RF SIGNAL .....	58
NO REVERSE RF SIGNAL.....	59
LOW OR DEGRADED REVERSE RF SIGNAL .....	60

## INTRODUCTION

The Quantum18 1.8 GHz System Amplifier is configured with modules that support different functions. This modular design approach provides the following benefits:

- The housing design has the flexibility to accept a variety of Diplex Filter modules.
- A future Quantum Link transponder can be added to allow full amplifier telemetry

This chapter describes the steps you may take to troubleshoot the Quantum18 1.8 GHz System Amplifier.

**NO AC POWER**



AC power can be measured at the AC power supply test points and power wiring harness.

Troubleshooting

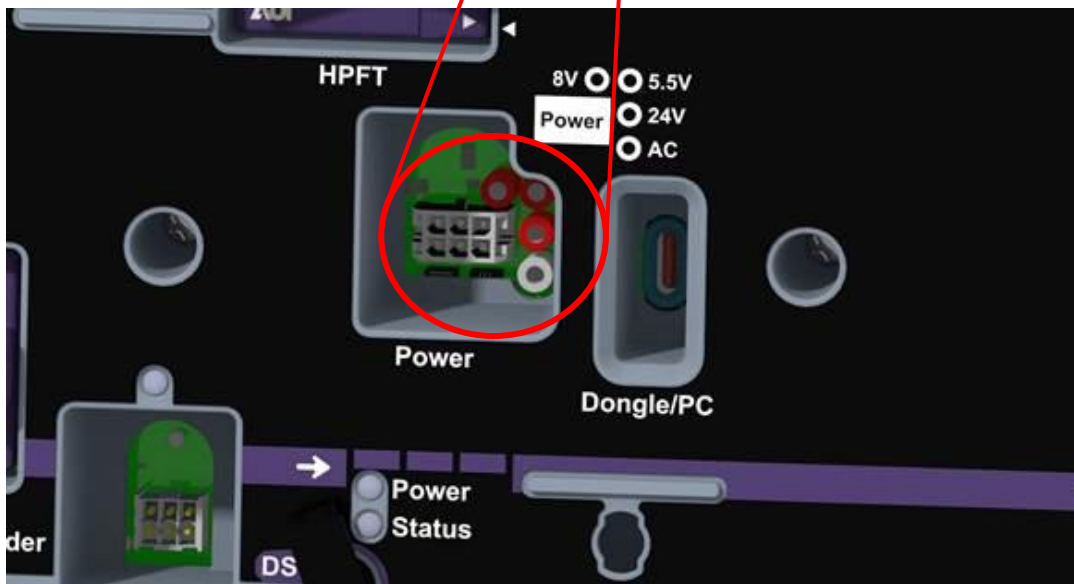
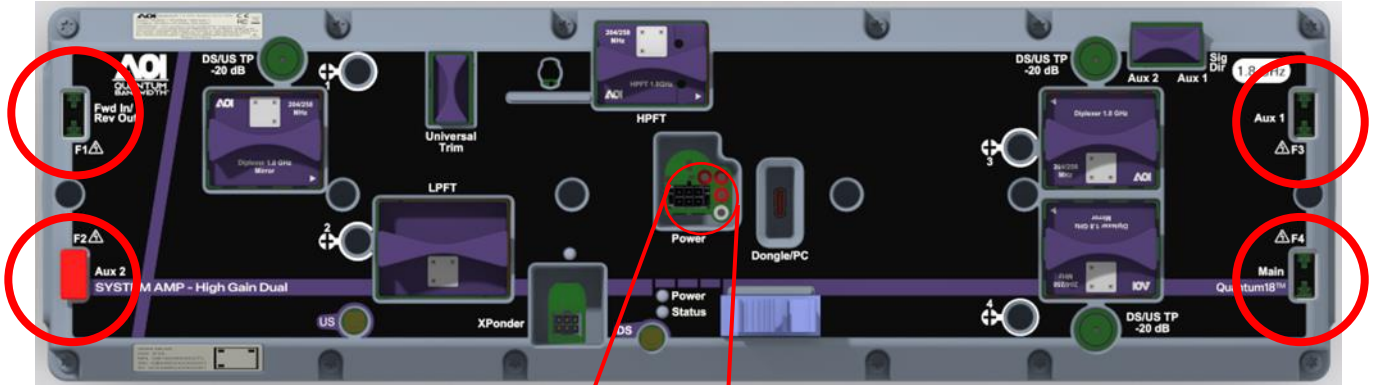

**Figure 4- 1 – AC Test Points**

AC power can be measured at the system amplifier seizure screws and AC test point next to the power harness on the system amplifier module.

### No AC Power Troubleshooting Table

Before you begin troubleshooting for no AC power, verify that there is proper AC power input coming into the system amplifier and that the AC voltage lockout threshold is set to your system's power requirements.

Possible Cause	Solution
<b>No AC at the Housing Seizure</b>	<ul style="list-style-type: none"> <li>■ Check the AC source.</li> <li>■ Check the AC shunt power director configuration at the System Amplifier feeding AC to this System Amplifier.</li> <li>■ Make sure that the housing seizure is properly tightened.</li> </ul>
<b>AC at the Housing Seizure But Not at the AC Test Point</b>	<ul style="list-style-type: none"> <li>■ Verify that the amp module is fully seated in the housing base and the screws tightened as specified.</li> <li>■ Check and / or replace the AC shunt power director.</li> <li>■ Check and / or replace the System Amplifier module.</li> </ul>

**NO DC POWER**



DC power can be measured at the DC power supply test points and power wiring harness.

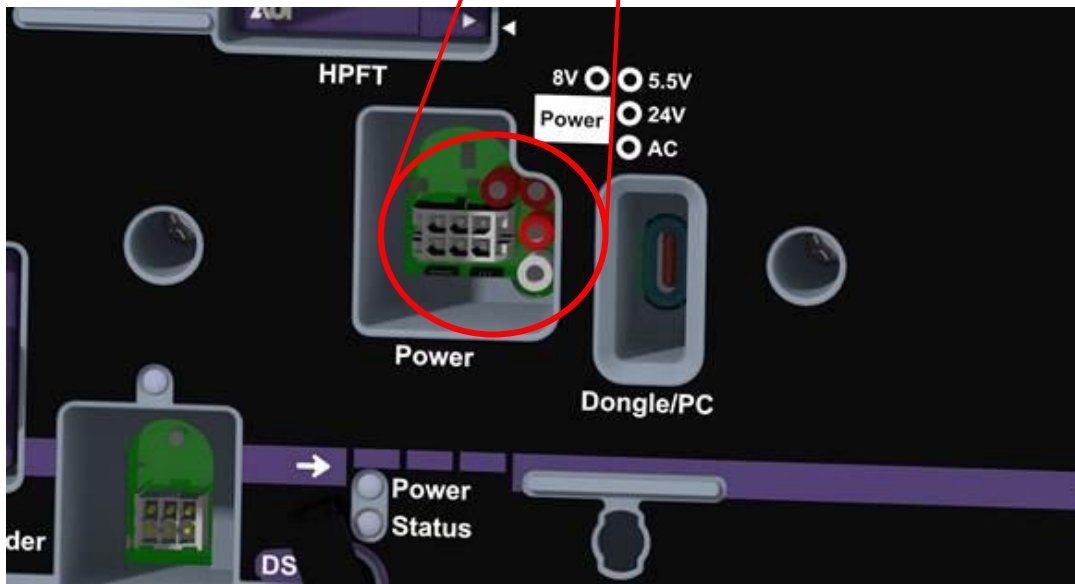
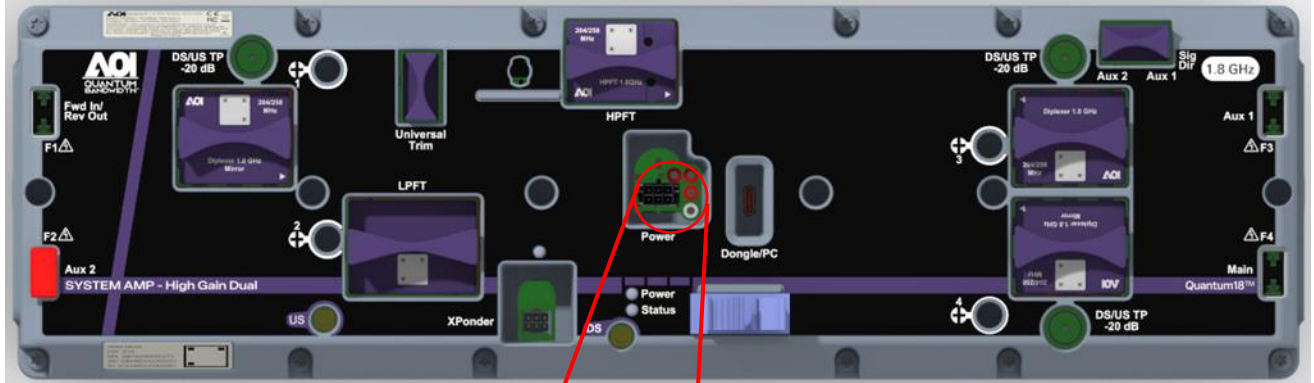

Figure 4- 2 – DC Test Points

**NO DC POWER TROUBLE SHOOTING TABLE**

Before you begin troubleshooting for no DC power, verify that there is proper AC power input coming into the DC power supply and that the AC voltage lockout threshold is set to your system's powering requirements.

Possible Cause	Solution
No DC Power at the amplifier DC test points	<ul style="list-style-type: none"> <li>■ Check and / or replace the power wiring harness</li> <li>■ Check and / or replace the power supply.</li> </ul>

## NO FORWARD RF SIGNAL

The forward RF signal can be measured at the system amplifier module forward input and forward output test points.

### No Forward RF Signal Troubleshooting Table

Before you begin troubleshooting for no forward RF signal, verify that the system amplifier is receiving the proper forward RF input signal from the upstream equipment.

**IMPORTANT:** *You cannot balance the system amplifier without the proper forward RF input signal.*

Possible Cause	Solution
<b>No Forward RF Signal at the Forward Input Test Point</b>	<ul style="list-style-type: none"> <li>■ Verify that the amp module is fully seated in the housing base and the screws tightened as specified.</li> <li>■ Verify the test point is configured to provide the forward input signal.</li> </ul>
<b>There Is Forward RF Signal at the Forward Input Test Point, But No Signal at One or All of the Forward Output Test Points</b>	<ul style="list-style-type: none"> <li>■ Verify that the amp module is fully seated in the housing base and the screws tightened as specified.</li> <li>■ Verify the test point is configured to provide the forward input signal.</li> <li>■ Verify that the system amplifier module is receiving the proper AC and DC voltages. Refer to “No AC Power and No DC Power”.</li> <li>■ Verify that all the plug-in accessories are firmly installed in the correct locations.</li> <li>■ Verify the power LED is on and red and status LED is blinking green. NEED TO CONFIRM THIS BEHAVIOR.</li> <li>■ Perform QuantumLink Local Downstream Auto-Alignment per Amplifier balancing, Section 3.</li> <li>■ Replace the system amplifier module.</li> </ul>

### LOW OR DEGRADED FORWARD RF SIGNAL

The forward RF signal can be measured at the system amplifier module forward input and forward output test points.

#### Low or Degraded Forward RF Signal Troubleshooting Table

Before you begin troubleshooting for a low or degraded forward RF signal, verify that the system amplifier is receiving the proper forward RF input signal from the upstream equipment.

**IMPORTANT:** *You cannot balance the system amplifier without the proper forward RF input signal.*

Make sure you have configured the system amplifier module according to the specifications in the design print, and that the system amplifier has warmed up for approximately one hour.

Possible Cause	Solution
Low or Degraded Forward RF Signal at the Forward Input Test Point	<ul style="list-style-type: none"> <li>Verify that the amp module is fully seated in the housing base and the screws tightened as specified.</li> </ul>
There is a Proper Forward RF Signal at the Forward Input Test Point, But a Low or Degraded Signal at One or All of the Forward Output Test Points	<ul style="list-style-type: none"> <li>Verify that the amp module is fully seated in the housing base and the screws tightened as specified.</li> <li>Verify that the system amplifier module is receiving the proper DC voltages. Refer to “<b>No DC Power</b>”.</li> <li>Verify that all the plug-in accessories are firmly installed in the correct locations.</li> <li>Verify the power LED is on and red and status LED is blinking green. NEED TO CONFIRM THIS BEHAVIOR.</li> <li>Perform the Downstream alignment process via the QuantumLink Local application. Refer to “<b>Balancing and Setup</b>”, <b>Section 3</b> for more information.</li> <li>Replace the system amplifier module.</li> </ul>

### NO REVERSE RF SIGNAL

The reverse RF signal can be measured at the system amplifier module reverse input and reverse output test points.

#### No Reverse RF Signal Troubleshooting Table

Before you begin troubleshooting for no reverse RF signal, verify that the system amplifier is receiving the proper reverse RF input signals from the downstream system amplifier at the system amplifier reverse input test point.

**IMPORTANT:** You cannot balance the system amplifier without the proper reverse RF input signals.

Possible Cause	Solution
<b>No Reverse RF Signal at the Reverse Input Test Point</b>	<ul style="list-style-type: none"> <li>■ Verify that the amp module is fully seated in the housing base and the screws tightened as specified.</li> <li>■ Verify the test point is configured to provide the reverse input signal.</li> </ul>
<b>There is a Proper Reverse RF Signal at the Reverse Input Test Point, But No Signal at the Reverse Output Test Point</b>	<ul style="list-style-type: none"> <li>■ Verify that the amp module is fully seated in the housing base and the screws tightened as specified.</li> <li>■ Verify the test point is configured to provide the reverse input signal.</li> <li>■ Verify that the system amplifier module is receiving the proper AC and DC voltages. Refer to “<b>No AC Power</b>” and “<b>No DC Power</b>”.</li> <li>■ Verify that the system amplifier module is receiving the proper forward RF signal. Refer to “<b>No Forward RF Signal</b>”.</li> <li>■ Verify that all the plug-in accessories are firmly installed in the correct locations.</li> <li>■ Verify the power LED is on and red and status LED is blinking green. NEED TO CONFIRM THIS BEHAVIOR.</li> <li>■ Replace the system amplifier module.</li> </ul>



## LOW OR DEGRADED REVERSE RF SIGNAL

The reverse RF signal can be measured at the system amplifier module reverse input and reverse output test points.

### Low or Degraded Reverse RF Signal Troubleshooting Table

Before you begin troubleshooting for a low or degraded reverse RF signal, verify that the system amplifier is receiving the proper reverse RF input signals from the downstream system amplifier at the system amplifier reverse input test point.

**IMPORTANT:** You cannot balance the system amplifier without the proper reverse RF input signals.

Make sure you have configured the system amplifier module according to the specifications in the design print, and that the system amplifier has warmed up for approximately one hour.

Make sure you are using the proper total tilt reference when setting receive levels. Refer to the reverse equalizer charts in “**Technical Information**” for more information.

**IMPORTANT:** If the system amplifier cover was ever removed, make sure it was properly reinstalled. Improperly reinstalling the system amplifier module cover may result in RF signal degradation.

Possible Cause	Solution
Low or Degraded Reverse RF Signal at the Reverse Input Test Point	<ul style="list-style-type: none"> <li>Verify that the amp module is fully seated in the housing base and the screws tightened as specified.</li> </ul>
There are Proper Reverse RF Signals at the Reverse Input Test Point, But a Low or Degraded Signal at the Reverse Output Test Point	<ul style="list-style-type: none"> <li>Verify that the amp module is fully seated in the housing base and the screws tightened as specified.</li> <li>Verify that the system amplifier module is receiving the proper DC voltages. Refer to “<b>No DC Power</b>”.</li> <li>Measure the main reverse input test point and the reverse output test point. Subtract the reverse amplifier gain and add the pad values and EQ insertion loss to verify proper reverse amplifier gain.</li> <li>Verify that all the plug-in accessories are firmly installed in the correct locations.</li> <li>Verify the power LED is on and red and status LED is blinking green. NEED TO CONFIRM THIS BEHAVIOR.</li> <li>Perform the Upstream alignment process via the QuantumLink Local application. Refer to “<b>Balancing and Setup</b>”, <b>Section 3</b> for more information.</li> </ul>

Installation and Operation Guide

Possible Cause	Solution
<p><b>Reverse RF Signal Still Low or Degraded</b></p>	<ul style="list-style-type: none"> <li>■ Use a spectrum analyzer to look at the reverse RF input signal spectral quality at each reverse input test point and compare it to the reverse RF output signal spectral quality.                             <ul style="list-style-type: none"> <li>– If degradation is generated in the reverse amplifier, replace the system amplifier module.</li> <li>– If degradation is generated by the downstream system amplifier reverse RF signal, troubleshoot the system amplifier feeding this station.</li> </ul> </li> <li>■ Replace the system amplifier module.</li> </ul>

# 5. CUSTOMER SUPPORT INFORMATION

## IF YOU HAVE QUESTIONS

---

If you have technical questions, call AOI for assistance. Follow the menu options to speak with a service engineer.

Access your company's extranet site to view or order additional technical publications. For accessing instructions, contact the representative who handles your account. Check your extranet site often as the information is updated frequently.

# RF SPLIT UPGRADE APPLICATION NOTE

# APPENDIX A: RF SPLIT UPGRADE APPLICATION NOTE

In this Application Note...

BEFORE YOU BEGIN.....2

UPGRADING THE RF SPLIT IN THE 1.8GHz SYSTEM AMPLIFIER .....4

CONNECT TO QUANTUMLINK LOCAL FOR CONFIGURATION AND VERIFICATION .....6

TO CLOSE THE SYSTEM AMPLIFIER HOUSING .....12

## RF SPLIT UPGRADE APPLICATION NOTE

**BEFORE YOU BEGIN****Introduction**

As cable operators face an exponential rise in the requirements for more reverse path bandwidth driven by the popularity of advanced, on-demand services from an increasing number of subscribers, operators need an upgrade path for deployed equipment to overcome this operational challenge. Commercial services driven by mixed-use urban environments is a practical example of geographic portions of the outside plant where the service provider may wish for more symmetric data services.

**Purpose**

This application note describes the RF split upgrade procedure for 1.8GHz System Amplifier.

You will note that the final instruction in the split change process calls for the verification the split change was successful using the QuantumLink Local Mobile Application. This verification is included to ensure that all component replacements with respect to the split upgrade were performed correctly and to ensure that all replacement components perform as specified.

Should you need assistance with your upgrade, contact Applied Optoelectronics Inc. for support.

**WARNING:**

Avoid electric shock. Opening or removing this equipment cover may expose you to dangerous voltages. RF split upgrades should only be conducted on amplifiers that have been removed from the cable system, not on amplifiers actively in service.

**Qualified Personnel****CAUTION:**

Allow only qualified and skilled personnel to install, operate, maintain, and service this product. Otherwise, personal injury, or equipment damage may occur.

**Related Publications**

You may find the following publications useful as you implement the procedures in this document.

- *Quantum18 - 1.8GHz System Amplifier Installation and Operation Guide*

## RF SPLIT UPGRADE APPLICATION NOTE

**Components Required to Make the Split Change**

- (1) Low Pass Filter Trim Assembly
- (1) High Pass Filter Trim Assembly
- (2) Mirrored Diplex Filters
- (1-HGD) (2-HGBT) Non-mirrored Diplex Filters
- Part number label

**NOTE:** *Part numbers differ depending on desired final split.*

**Equipment Required to Make the Split Change**

- 1/2-inch socket driver
- Torque wrench with 1/2-inch socket

## RF SPLIT UPGRADE APPLICATION NOTE

**UPGRADING THE RF SPLIT IN THE 1.8GHz SYSTEM AMPLIFIER**

There are two methods associated with upgrading the RF split of an amplifier in the field. The first method is upgrading the RF Split on the Amplifier Module by swapping the accessories to the new frequency split without powering down the amplifier. The second method is to swap the existing Amplifier module with a new amplifier module that has the new split. Swapping the Amplifier modules in the field requires removing power from the original Amplifier module before removal and powering the new Amplifier module after installation. Removing the **Red** shunt, removes power from the Amplifier module. After installing the replacement Amplifier module, power is restored by installing the **Red** shunt in the same location as previously used. The Black shunt, if used, will allow power to be fed down/up the line.

**NOTE: For Amplifier module installation, after module is installed, install the Black Shunt first and then install the Red Shunt.**

The follow the steps outline upgrading the RF Split for the 1.8GHz Amplifier Module, presently installed in the field, by swapping the accessories to the new frequency split.

**IMPORTANT: Before unscrewing the housing closure bolts, if the housing uses a locking screw, make sure the removable locking screw in the hinge is in place and secure. The locking screw prevents separation of the lid from the base.**

**Upgrading the Amplifier Module**

1. Unscrew the ½-inch housing closure bolts on the housing lid until they are loose.

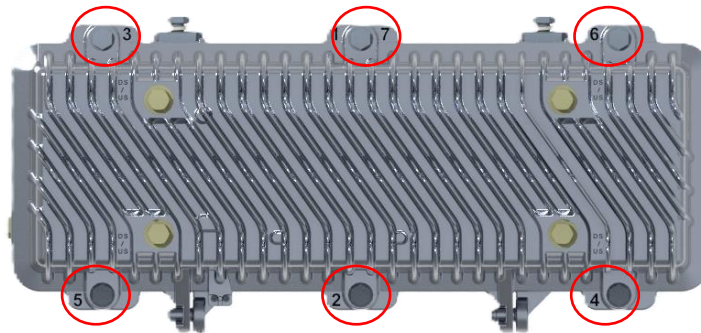

**Figure A- 1: Housing Closure Bolt Locations**



RF SPLIT UPGRADE APPLICATION NOTE

2. Open the housing.
  - NOTE: The housing closure bolts will remain attached to the housing.**
3. Remove the Diplex filters, High Pass Filter Trim and Low Pass Filter Trim

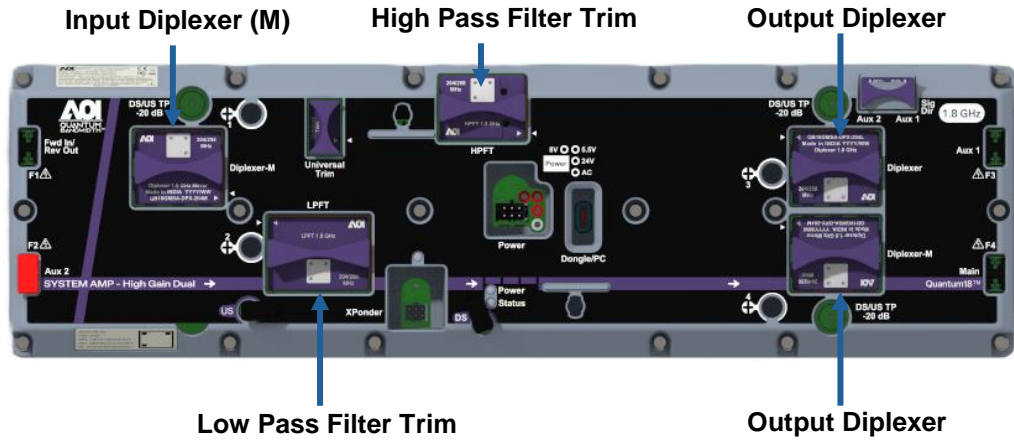

Figure A- 2: HGD Filter / Diplexer Locations

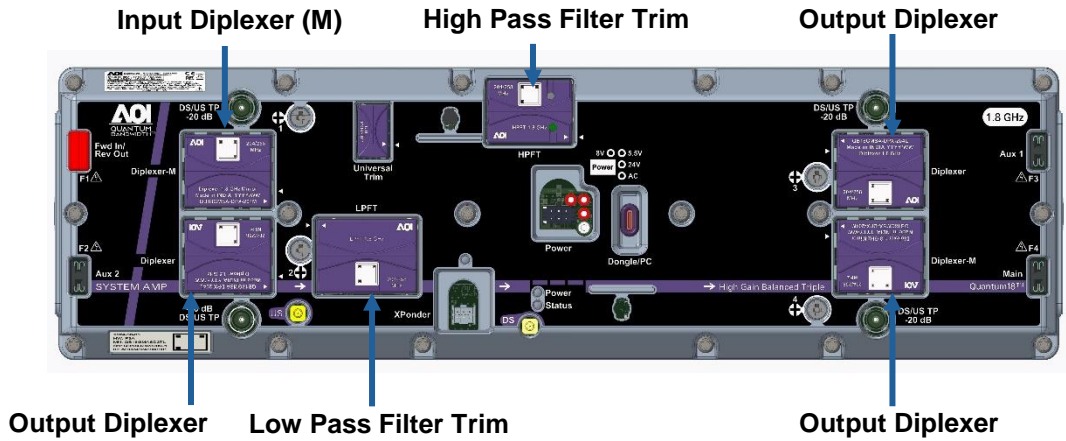

Figure A- 3: HGBT Filter / Diplexer Locations

4. Install the new Diplex filters, High Pass Filter Trim and Low Pass Filter Trim – proceed to connecting QuantumLink Local Wireless Interface for configuration and verification.

RF SPLIT UPGRADE APPLICATION NOTE

**CONNECT TO QUANTUMLINK LOCAL FOR CONFIGURATION AND VERIFICATION**

1. An Android or iOS device with the QuantumLink Local Mobile Application is used to establish a Bluetooth connection with the QuantumLink Local Wireless Interface plugged into the Quantum18 1.8 GHz System Amplifier module (shown below).

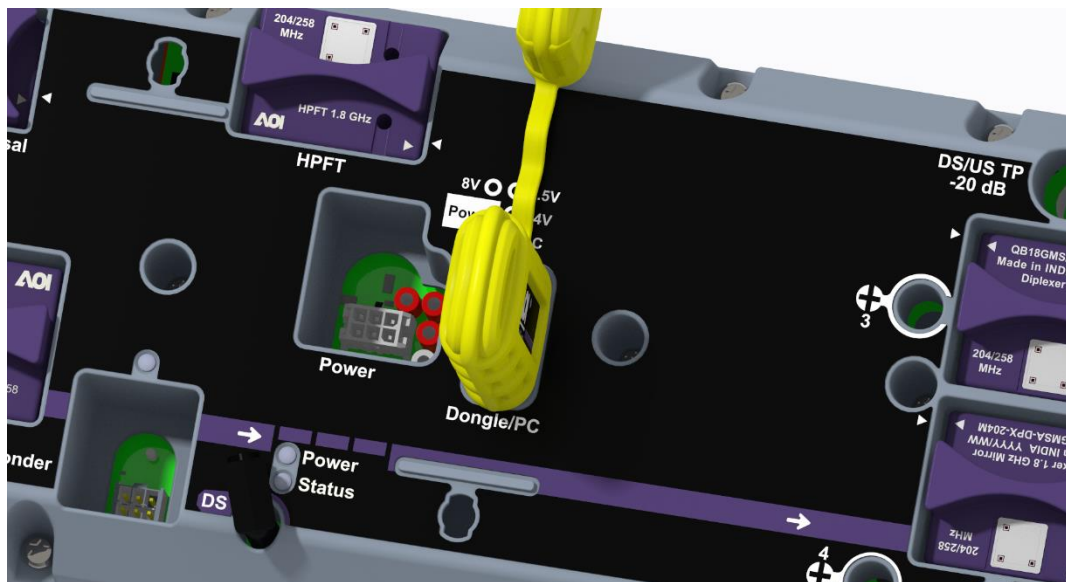

*Figure A- 4: QuantumLink Local Wireless Interface Installed in a SA*

RF SPLIT UPGRADE APPLICATION NOTE

2. Preparing for RF Split Upgrade

- Locate and Initiate QuantumLink Local Mobile Application on the Technician’s portable device (Tablet/Handheld), see Figure A-5.
- Insert the QuantumLink Local Wireless Interface in the Quantum18 1.8 GHz System Amplifier module as shown above see Figure A-4.
- Establish point to point connections via Bluetooth between the technician’s portable device and the QuantumLink Local Wireless Interface by using “Select Device” drop down in the QuantumLink Local Mobile Application menu to select the proper QuantumLink Local Wireless Interface.
- Log into the QuantumLink Local Mobile Application, using an accepted username and password, see Figure A-7.

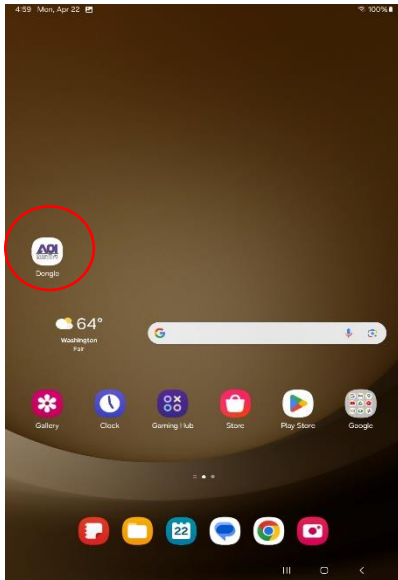

Figure A- 5: Android Home Screen

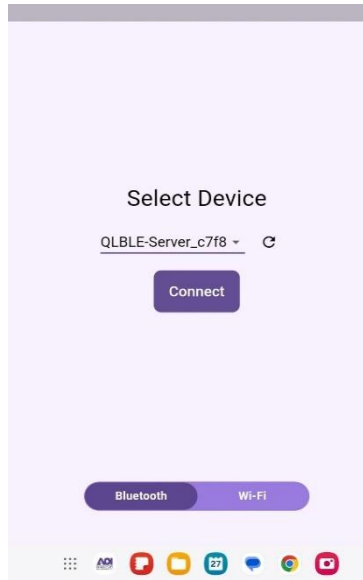

Figure A- 6: Device Connection

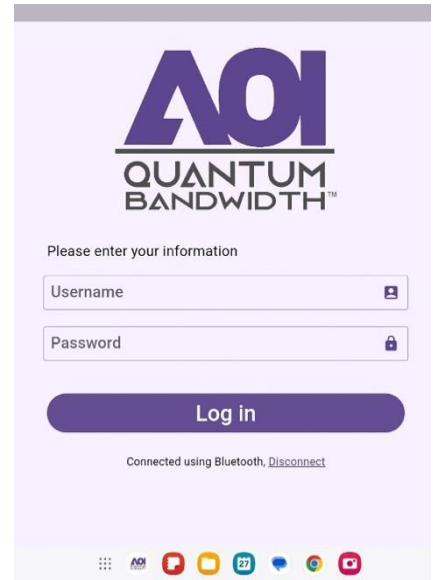

Figure A- 7: Login

A.

RF SPLIT UPGRADE APPLICATION NOTE

3. From the Home screen, select the Amplifier Config Tile, see Figure A-8.
4. Diplex Filter – Select the new split from the frequency split drop down menu, see Figure A-9.
5. Save changes and return to the Home screen.

Appendix A: RF Split Upgrade Application Note

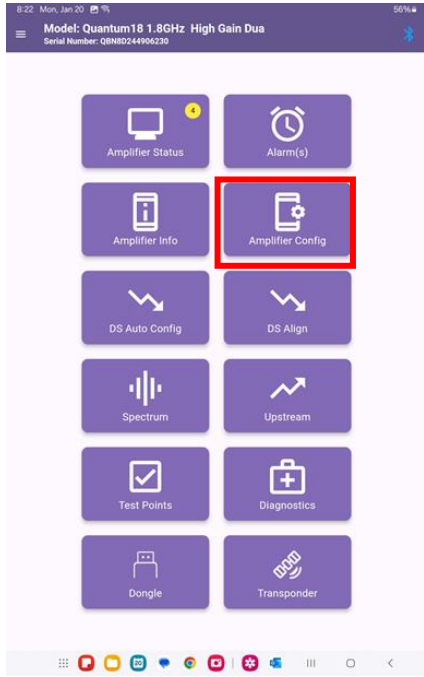

**Figure A- 8: Amplifier Config Tile**

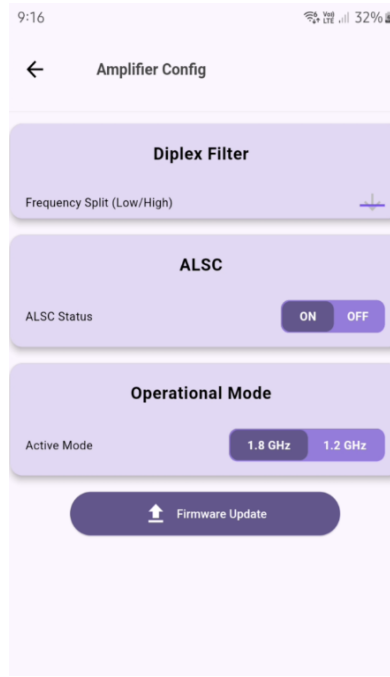

**Figure A- 9: Amplifier Info Details**

RF SPLIT UPGRADE APPLICATION NOTE

6. Select the DS Auto Config Tile, see Figure A-10.
7. Confirm the Downstream Config Parameters for: Auto Config, ALSC and Auto Align Marker Pilots correctly matches the site profile data loaded. Once confirmed select “Apply” and return to the Home screen, see Figure A-11.

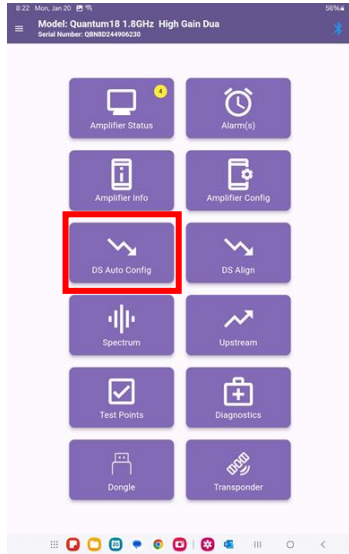

Figure A- 10: DS Auto Config Tile



Figure A- 11: Configuration Settings

RF SPLIT UPGRADE APPLICATION NOTE

8. Select the DS Align Tile Figure A-12
9. Verify pilot carriers (frequency) are correctly stored in the amplifier. Once confirmed, return to the Home screen.

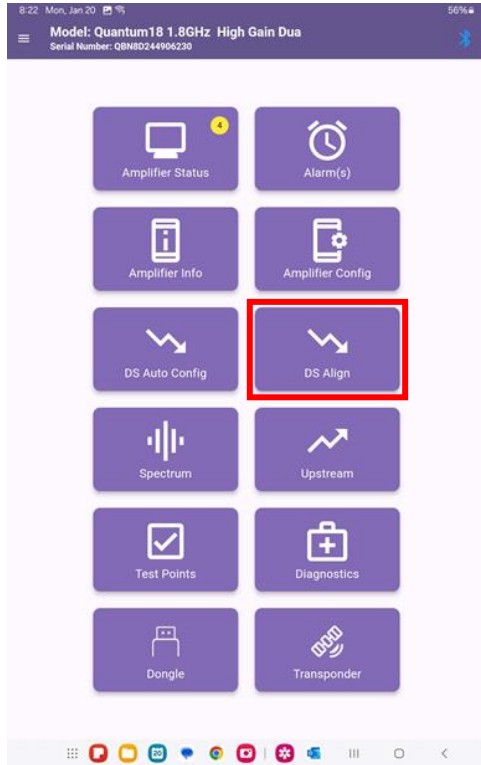

Figure A- 12: DS Align Tile



Figure A- 13: Alignment Settings

RF SPLIT UPGRADE APPLICATION NOTE

10. Select Spectrum Tile, see Figure A-14.
11. Execute a Spectrum Capture “spectrum capture. Verify that the spectrum displayed begins at the appropriate frequency and that the measured signal level closely correlates with the target level, see Figure A-15.

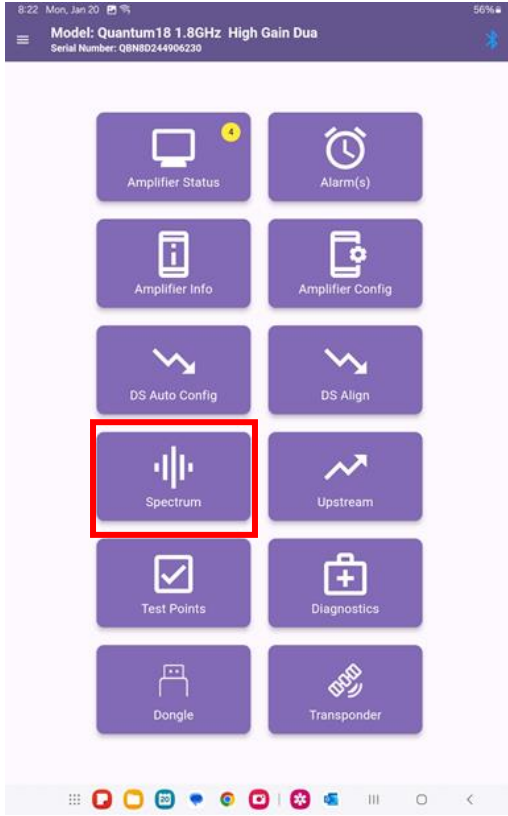

Figure A- 14: Spectrum Tile

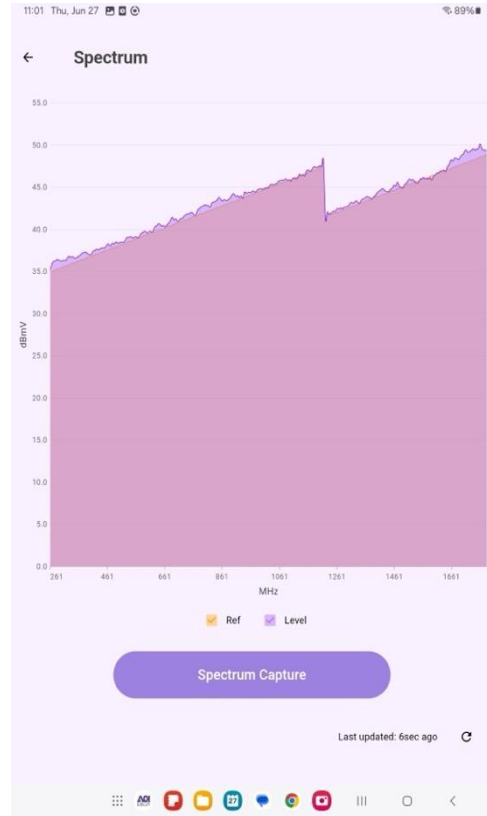

Figure A- 15: Spectrum Capture

12. Final Step – Remove the QuantumLink Local Wireless Interface, before closing lid.

## RF SPLIT UPGRADE APPLICATION NOTE

**TO CLOSE THE SYSTEM AMPLIFIER HOUSING**

1. Close the housing and finger-tighten all housing closure bolts.
2. Use a torque wrench with a ½-inch socket to tighten each closure bolt from 5 ft-lb to 12 ft-lb (6.8 Nm to 16.3 Nm) each.
3. Follow the numbered tightening sequence to tighten the housing closure bolts.

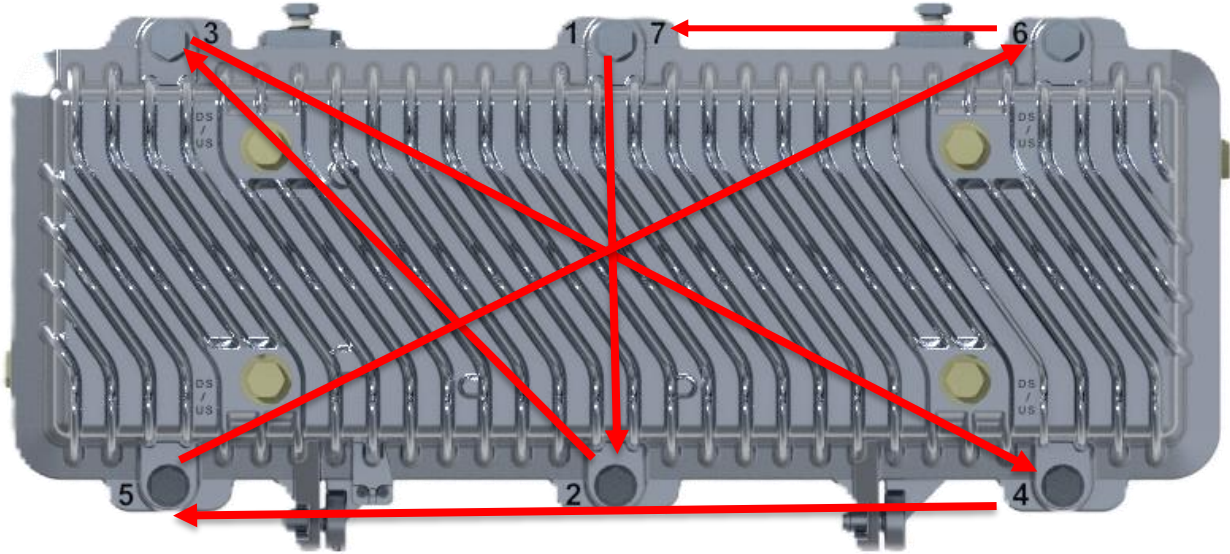
*Figure A- 16 - Torque Sequence*



# TRANSPONDER INSTALLATION APPLICATION NOTE

# APPENDIX B: TRANSPONDER INSTALLATION APPLICATION NOTE

In this Application Note...

BEFORE YOU BEGIN.....	2
INSTALLING THE TRANSPONDER.....	3
TO CLOSE THE SYSTEM AMPLIFIER HOUSING .....	4

## BEFORE YOU BEGIN

### Introduction

The QuantumLink (QL) Transponder is designed to be installed in the lid of the Quantum Bandwidth (QB)18 Amplifier housing. The Transponder complies with the Society of Cable Telecommunications Engineers (SCTE) and Cable Labs standard, which allows an element management system (EMS) to monitor the components in a cable network.

The transponder can be configured after it is installed in a powered amplifier, either on a test bench or on site. The transponder must have an authorized Security Key before it can be activated in the EMS.

### Purpose

These installation instructions will enable cable system operators or installers to properly install and configure a QL Transponder in a QB18 System Amplifier.

Should you need assistance with your upgrade, contact Applied Optoelectronics Inc. for support.

### Audience

This document is intended for authorized service personnel who have experience working with similar equipment. The service personnel should have appropriate background and knowledge to complete the procedures described in this document.

### Qualified Personnel



#### CAUTION:

Allow only qualified and skilled personnel to install, operate, maintain, and service this product. Otherwise, personal injury, or equipment damage may occur.

### Related Publications

You may find the following publications useful as you implement the procedures in this document.

- *Quantum18 - 1.8GHz System Amplifier Installation and Operation Guide*

### Equipment Required

- Transponder with authorized Security Key
- 1/2-inch socket driver
- Philips-head screwdriver
- Torque wrench to support a 1/2-inch socket and a Philips-head

### INSTALLING THE TRANSPONDER

The transponder module mounts in the lid of the QB18 housing. The transponder mounting location is shown below.

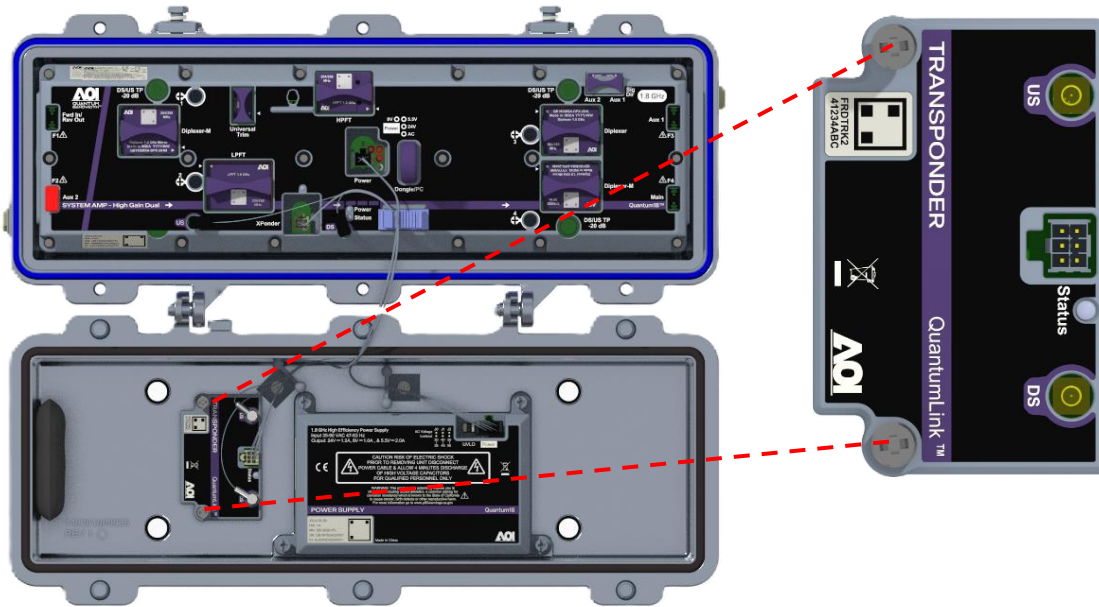

Figure B- 1: Transponder Screw Location

1. Open the QB18 housing and place the transponder in the lid with the QR-code label facing you.

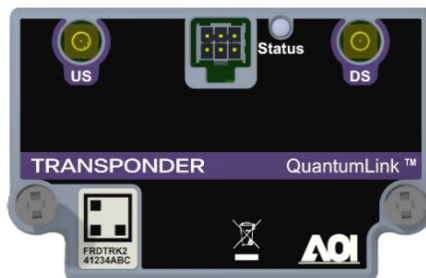
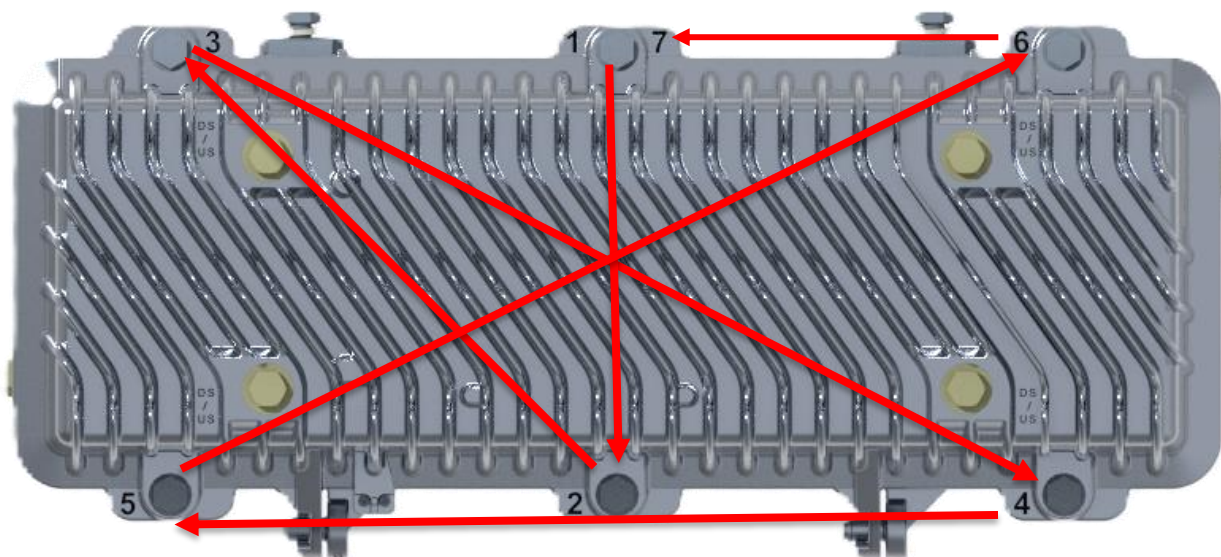

Figure B- 2: Transponder

2. Tighten the two module retaining screws on the transponder to 17 in-lb (2 Nm).
3. Connect the RF cables (DS and US) from the transponder to the amplifier module in the housing base. Ensure the DS cable from the Transponder is connected to DS on the Amplifier module and US cable from the Transponder is connected to US on the amplifier module.  
**NOTE: Route RF cables through Cable Management clips.**
4. Connect Power Supply cable to the transponder.  
**NOTE: The Status LED will briefly turn Red during bootup and then turn Green, to indicate it is operational**

**TO CLOSE THE SYSTEM AMPLIFIER HOUSING**

- 1 Close the housing and finger-tighten all housing closure bolts.
- 2 Use a torque wrench with a ½-inch socket to tighten each housing closure bolt from 10 to 12 ft-lb (13.6 to 16.3 Nm) each.
- 3 Follow the numbered tightening sequence to tighten the housing closure bolts.
- 4 The transponder is now discoverable by QL Node Gateway and/or QL Central application.



*Figure B- 3: Housing Closure Bolt Torquing Sequence*

# GLOSSARY

<b>A</b>	Ampere A unit of measure for electrical current.
<b>ac / AC</b>	Alternating Current An electric current that reverses its direction at regularly recurring intervals.
<b>ALSC</b>	Automatic Slope & Level Control A process or means by which gain is automatically adjusted in a specified manner as a function of input level or other specified parameters.
<b>CW</b>	Continuous Wave
<b>dB</b>	Decibel One tenth of a bel, the number of decibels denoting the ratio of two amounts of power being ten times the common logarithm of this ratio.
<b>dBc</b>	Decibels relative to a reference carrier.
<b>dBm</b>	Decibels relative to one milliwatt.
<b>dBmV</b>	Decibels relative to one millivolt.
<b>dBW</b>	Decibels relative to one watt.
<b>dc / DC</b>	Direct Current An electric current flowing in one direction only and substantially constant in value.
<b>DS</b>	Down Stream – Reverse Path
<b>DUT</b>	Device Under Test
<b>EMC</b>	Electromagnetic Compatibility A measure of equipment tolerance to external electromagnetic fields.
<b>EQ</b>	Equalizer
<b>Equalization</b>	The process of compensating for an undesired result. For example, equalizing tilt in a distribution system.

Glossary

<b>FCC</b>	Federal Communications Commission Federal organization set up by the Communications Act of 1934 which has authority to regulate all inter-state (but not intra-state) communications originating in the United States (radio, television, wire, satellite, and cable).
<b>FEV</b>	Front Equipment View
<b>ft-lb</b>	Foot-Pound A measure of torque defined by the application of one pound of force on a lever at a point on the lever that is one foot from the pivot point.
<b>Gain</b>	A measure of the increase in signal level, relative to a reference, in an amplifier. Usually expressed in decibels.
<b>GHz</b>	Gigahertz A unit of frequency equal to one billion cycles per second.
<b>Hertz</b>	A unit of frequency equal to one cycle per second.
<b>I/O</b>	Input / Output
<b>in-lb</b>	Inch-Pound A measure of torque defined by the application of one pound of force on a lever at a point on the lever that is one inch from the pivot point.
<b>LE</b>	System amplifier
<b>LED</b>	Light-Emitting Diode An electronic device that lights up when electricity passes through it.
<b>Mbps</b>	Megabits Per Second A unit of measure representing a rate of one million bits (megabits) per second.
<b>MHz</b>	Megahertz A unit of measure representing one million cycles per second; measures bandwidth.
<b>N-cm</b>	Newton Centimeter

Glossary

<b>Nm</b>	<p>Newton Meter</p> <p>A measure of torque defined by the application of one Newton of force on a lever at a point on the lever that is one meter from the pivot point (1 Nm = 0.737561 ft-lb).</p>
<b>PCB/PWB</b>	<p>Printed Circuit Board/Printed Wiring Board</p>
<b>RF</b>	<p>Radio Frequency</p> <p>The frequency in the portion of the electromagnetic spectrum that is above the audio frequencies and below the infrared frequencies, used in radio transmission systems.</p>
<b>RMA</b>	<p>Return Material Authorization</p> <p>A form used to return products.</p>
<b>RX</b>	<p>Receive or Receiver</p>
<b>S/N or SNR</b>	<p>Signal-to-Noise Ratio</p> <p>The ratio, in decibels, of the maximum peak-to-peak voltage of the video signal, including synchronizing pulse, to the root-mean-square voltage of the noise. Provides a measure and indication of signal quality.</p>
<b>SA</b>	<p>System Amplifier</p>
<b>Torque</b>	<p>A force that produces rotation or torsion. Usually expressed in lb-ft (pound-feet) or N-m (Newton-meters). The application of one pound of force on a lever at a point on the lever that is one foot from the pivot point would produce 1 lb-ft of torque.</p>
<b>TX</b>	<p>Transmit or Transmitter</p>
<b>US</b>	<p>Up Stream – Forward Path</p>
<b>V</b>	<p>Volt</p>
<b>V AC</b>	<p>Volts Alternating Current</p>
<b>V DC</b>	<p>Volts Direct Current</p>
<b>W</b>	<p>Watt</p> <p>A measure of electrical power required to do work at the rate of one joule per second. In a purely resistive load, 1 Watt = 1 Volt x 1 Amp.</p>





**World Headquarters** Applied  
Optoelectronics, Inc. 13139 Jess  
Pirtle Boulevard Sugar Land, TX  
77478

AOI and the AOI logo are trademarks or registered trademarks of AOI and / or its affiliates in the U.S. and other countries. To view a list of AOI trademarks, go to this URL:

<http://www.ao-inc.com>