

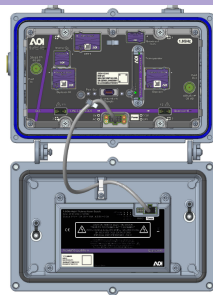

Quantum18 BLE 1.8GHz Line Extender

INSTALLATION AND OPERATION GUIDE



13139 Jess Pirtle Boulevard, Sugar Land, TX 77478 | T: 281.295.1800







V02032025a

For Your Safety

EXPLANATION OF WARNING AND CAUTION ICONS.

Avoid personal injury and product damage! Do not proceed beyond any symbol until you fully understand the indicated conditions.

The following warning and caution icons alert you to important information about the safe operation of this product:

	<p>You may find this symbol in the document that accompanies this product. This symbol indicates important operating or maintenance instructions.</p>
	<p>You may find this symbol affixed to the product. This symbol indicates a live terminal where a dangerous voltage may be present; the tip of the flash points to the terminal device.</p>
	<p>You may find this symbol affixed to the product. This symbol indicates a protective ground terminal.</p>
	<p>You may find this symbol affixed to the product. This symbol indicates a chassis terminal (normally used for equipotential bonding).</p>
	<p>You may find this symbol affixed to the product. This symbol warns of a potentially hot surface.</p>
	<p>You may find this symbol affixed to the product and in this document. This symbol indicates an infrared laser that transmits intensity-modulated light and emits invisible laser radiation or an LED that transmits intensity-modulated light.</p>

IMPORTANT

Please read this entire guide. If this guide provides installation or operation instructions, give particular attention to all safety statements included in this guide.

Notices

TRADEMARK ACKNOWLEDGEMENTS

- AOI, the AOI logo, Applied Optoelectronics, the AOI logo, and Quantum Bandwidth are trademarks or registered trademarks of Applied Optoelectronics, Inc. and / or its affiliates in the U.S. and certain other countries.
- All other trademarks mentioned in this document are the property of their respective owners.

PUBLICATION DISCLAIMER

Applied Optoelectronics, Inc., assumes no responsibility for errors or omissions that may appear in this publication. We reserve the right to change this publication at any time without notice. This document is not to be construed as conferring by implication, estoppel, or otherwise any license or right under any copyright or patent, whether or not the use of any information in this document employs an invention claimed in any existing or later issued patent.

COPYRIGHT

©2025 Applied Optoelectronics, Inc. All rights reserved. Printed in the United States of America.

Information in this publication is subject to change without notice. No part of this publication may be reproduced or transmitted in any form, by photocopy, microfilm, xerography, or any other means, or incorporated into any information retrieval system, electronic or mechanical, for any purpose, without the express permission of Applied Optoelectronics, Inc.

Table of Contents

<i>For Your Safety</i>	<i>II</i>
EXPLANATION OF WARNING AND CAUTION ICONS.	II
IMPORTANT	II
<i>Notices</i>	<i>III</i>
TRADEMARK ACKNOWLEDGEMENTS	III
PUBLICATION DISCLAIMER.....	III
COPYRIGHT	III
<i>Important Safety Instructions</i>	<i>VIII</i>
FOLLOW INSTRUCTIONS AND HEED WARNINGS	VIII
TERMINOLOGY.....	VIII
ELECTRIC SHOCK HAZARD	VIII
EQUIPMENT PLACEMENT.....	IX
STRAND (AERIAL) INSTALLATION.....	IX
PEDESTAL, SERVICE CLOSET, EQUIPMENT ROOM OR UNDERGROUND VAULT INSTALLATION	IX
CONNECTING TO UTILITY AC POWER.....	IX
CONNECTION TO NETWORK POWER SOURCES.....	X
AC POWER SHUNTS	X
EQUIPOTENTIAL BONDING	X
GENERAL SERVICING PRECAUTIONS	X
ELECTROSTATIC DISCHARGE	XI
SHUNT REPLACEMENT	XII
MODIFICATIONS	XII
ACCESSORIES	XII
ELECTROMAGNETIC COMPATIBILITY REGULATORY REQUIREMENTS.....	XII
EMC COMPLIANCE STATEMENTS	XIII
FCC Statement for Class A Equipment.....	XIII
Industry Canada – Industrie Canadiene Statement	XIII
CENELEC / CISPR Statement with Respect to Class A Information Technology Equipment	XIII
1. Introduction	1
OVERVIEW	2
PURPOSE	2
WHO SHOULD USE THIS DOCUMENT.....	2
QUALIFIED PERSONNEL	2
SCOPE	2
EQUIPMENT.....	2

Installation and Operation Guide

DESCRIPTION	3
Characteristics	3
Power Supply.....	4
Input and Output Ports	4
Configuration.....	4
RF Test Points	5
AC/DC Power Management.....	5
ILLUSTRATIONS	6
Quantum18 BLE 1.8GHz Line Extender Accessories	6
Ordering Information.....	8
BLOCK DIAGRAM	9
2. Installation and Configuration.....	10
OVERVIEW	11
BEFORE YOU BEGIN	12
Required Equipment.....	12
Torque Specifications	12
MODULE AND HOUSING COMPATABILITY	13
Housing Lid	13
Housing Base	13
Housing Dimensions	13
OPENING THE HOUSING.....	14
UPGRADING EXISTING HOUSING SEIZURES	15
To Install the New Housing Seizures	15
UPGRADING AN EXISTING HOUSING LID	16
To Install the New Housing Lid	16
INSTALLING THE POWER SUPPLY	18
To Install the Power Supply Module.....	18
To Set the AC Undervoltage Lockout Selector.....	20
ATTACHING THE COAXIAL CONNECTORS.....	21
To Trim the Center Conductor.....	21
To Connect the Coaxial Cable Pin Connector to the Housing	22
INSTALLING THE HOUSING	22
To Install the Housing on a Strand (Aerial).....	22
Signal Flow From Left to Right.....	23
Signal Flow From Right to Left.....	23
To Install the Housing in a Pedestal	24
INSTALLING THE AMPLIFIER MODULE	25
To Install the Amplifier Module	25
REMOVING THE AMPLIFIER MODULE FROM THE HOUSING	27
To Remove the Amplifier Module	27
CLOSING THE HOUSING	28
To close the Housing.....	28
Torqueing Sequence	28

Installation and Operation Guide

3. Balancing and Setup	29
INTRODUCTION	30
PREPARING FOR AMPLIFIER SET-UP	31
VERIFY/UPDATE AMPLIFIER INFORMATION	33
VERIFY/UPDATE AMPLIFIER CONFIGURATION	34
LOCATION DATA	35
DOWNSTREAM PROFILE CONFIGURATION	36
DOWNSTREAM AUTO ALIGNMENT	37
DOWNSTREAM MANUAL ALIGNMENT	38
VIEW DOWNSTREAM SPECTRUM	39
UPSTREAM ALIGNMENT	40
UPSTREAM ALIGNMENT...continued	41
CASCADE ALSC ACTIVATION	42
TEST POINTS	43
DIAGNOSTICS	44
4. TROUBLESHOOTING	45
INTRODUCTION	46
NO AC POWER	47
No AC Power Troubleshooting Table	47
NO DC POWER	48
No DC Troubleshooting Table	48
NO FORWARD RF SIGNAL	49
No Forward RF Signal Troubleshooting Table	49
LOW OR DEGRADED FORWARD RF SIGNAL	50
Low or Degraded Forward RF Signal Troubleshooting Table	50
NO REVERSE RF SIGNAL	51
No Reverse RF Signal Troubleshooting Table	51
LOW OR DEGRADED REVERSE RF SIGNAL	52
Low or Degraded Reverse RF Signal Troubleshooting Table	52
5. CUSTOMER SUPPORT INFORMATION	54
IF YOU HAVE QUESTIONS	54
RF SPLIT UPGRADE APPLICATION NOTE	1
BEFORE YOU BEGIN	2
Introduction.....	2
Purpose.....	2
Qualified Personnel	2
Related Publications	2

Installation and Operation Guide

Components Required to Make the Split Change..... 3
Equipment Required to Make the Split Change 3
UPGRADING THE RF SPLIT IN THE QUANTUM 18 BLE 1.8GHZ LINE EXTENDER 4
 Upgrading the Amplifier Module 4
CONNECT TO QUANTUMLINK LOCAL FOR CONFIGURATION AND VERIFICATION 9
TO CLOSE THE HOUSING 15
GLOSSARY..... 1

Important Safety Instructions

Carefully read all safety and operating instructions before operating this equipment and retain them for future reference.

FOLLOW INSTRUCTIONS AND HEED WARNINGS

Follow all operating and use instructions. Pay attention to all warnings and cautions in the operating instructions, as well as those that are affixed to this equipment.

TERMINOLOGY

The terms defined below are used in this document. The definitions given are based on those found in the safety standards

Service Personnel:	The term service personnel applies to trained and qualified individuals who are allowed to install, replace, or service electrical equipment. The service personnel are expected to use their experience and technical skills to avoid possible injury to themselves and others due to hazards that exist in service and restricted access areas.
User and Operator:	The terms user and operator apply to persons other than service personnel.
Ground(ing) and Earth(ing):	The terms ground(ing) and earth(ing) are synonymous. This document uses ground(ing) for clarity, but it can be interpreted as having the same meaning as earth(ing).

ELECTRIC SHOCK HAZARD

This equipment meets applicable safety standards.

	<p>WARNING:</p> <p>To reduce risk of electric shock, perform only the instructions that are included in the operating instructions. Refer all servicing to qualified service personnel only.</p>
---	---

Electric shock can cause personal injury or even death. Avoid direct contact with dangerous voltages at all times.

Know the following safety warnings and guidelines:

- Only qualified service personnel are allowed to perform equipment installation or replacement.
- Only qualified service personnel are allowed to remove chassis covers and access any of the components inside the chassis.

Installation and Operation Guide

EQUIPMENT PLACEMENT**WARNING:**

Avoid personal injury and damage to this equipment. An unstable mounting surface may cause this equipment to fall.

To protect against equipment damage or injury to personnel, comply with the following:

- Install this equipment in a restricted access location (access restricted to service personnel).
- Make sure the mounting surface or rack is stable and can support the size and weight of this equipment.

STRAND (AERIAL) INSTALLATION**CAUTION:**

Be aware of the size and weight of strand-mounted equipment during the installation operation.

Ensure that the strand can safely support the equipment's weight.

PEDESTAL, SERVICE CLOSET, EQUIPMENT ROOM OR UNDERGROUND VAULT INSTALLATION**WARNING:**

Avoid the possibility of personal injury. Ensure proper handling / lifting techniques are employed when working in confined spaces with heavy equipment.

- Ensure this equipment is securely fastened to the mounting surface or rack where necessary to protect against damage due to any disturbance and subsequent fall.
- Ensure the mounting surface or rack is appropriately anchored according to manufacturer's specifications.
- Ensure the installation site meets the ventilation requirements given in the equipment's data sheet to avoid the possibility of equipment overheating.
- Ensure the installation site and operating environment is compatible with the equipment's International Protection (IP) rating specified in the equipment's data sheet.

CONNECTING TO UTILITY AC POWER

IMPORTANT: *If this equipment is Class I equipment, it must be grounded.*

- Connect this equipment only to the power sources that are identified on the equipment-rating label, which is normally located close to the power inlet connector(s).

Installation and Operation Guide

CONNECTION TO NETWORK POWER SOURCES

Refer to this equipment's specific installation instructions in this manual or in companion manuals in this series for connection to network ferro-resonant AC power sources.

AC POWER SHUNTS

AC power shunts are provided with this equipment.

IMPORTANT: *The power shunts must be removed before installing modules into a powered housing. With the shunts removed, power surge to the components and RF-connectors is reduced.*

**CAUTION:**

RF connectors and housing seizure assemblies can be damaged if shunts are not removed from the equipment before installing or removing modules from the housing. A red shunt indicates the input power port.

EQUIPOTENTIAL BONDING

If this equipment is equipped with an external chassis terminal marked with the IEC 60417-5020 chassis icon () , the installer should refer to CENELEC standard EN 50083-1 or IEC standard IEC 60728-11 for correct equipotential bonding connection instructions.

GENERAL SERVICING PRECAUTIONS**WARNING:**

Avoid electric shock! Opening or removing this equipment's cover may expose you to dangerous voltages.

**CAUTION:**

These servicing precautions are for the guidance of qualified service personnel only. To reduce the risk of electric shock, do not perform any servicing other than that contained in the operating instructions unless you are qualified to do so. Refer all servicing to qualified service personnel.

Be aware of the following general precautions and guidelines.

1. SERVICING

Servicing is required when this equipment has been damaged in any way, liquid has been spilled or objects have fallen into this equipment, this equipment has been exposed to rain or moisture, does not operate normally, or has been dropped.

Installation and Operation Guide

2. WRISTWATCH AND JEWELRY

For personal safety and to avoid damage of this equipment during service and repair, do not wear electrically conducting objects such as a wristwatch or jewelry.

3. LIGHTNING

Do not work on this equipment, or connect or disconnect cables, during periods of lightning.

4. LABELS

Do not remove any warning labels. Replace damaged or illegible warning labels with new ones.

5. COVERS

Do not open the cover of this equipment and attempt service unless instructed to do so in the instructions. Refer all servicing to qualified service personnel only.

6. MOISTURE

Do not allow moisture to enter this equipment.

7. CLEANING

Use a damp cloth for cleaning.

8. SAFETY CHECKS

After service, assemble this equipment and perform safety checks to ensure it is safe to use before putting it back into operation.

ELECTROSTATIC DISCHARGE

Electrostatic discharge (ESD) results from the static electricity buildup on the human body and other objects. This static discharge can degrade components and cause failures.

Take the following precautions against electrostatic discharge:

- Use an anti-static bench mat and a wrist strap or ankle strap designed to safely ground ESD potentials through a resistive element.
- Keep components in their anti-static packaging until installed.
- Avoid touching electronic components when installing a module.

Installation and Operation Guide

SHUNT REPLACEMENT

To replace a shunt, comply with the following:

- Disconnect the power before changing shunts.
- Identify and clear the condition that caused the original shunt failure.
- Always use a shunt of the correct type and rating.

MODIFICATIONS

This equipment has been designed and tested to comply with applicable safety, laser safety, and EMC regulations, codes, and standards to ensure safe operation in its intended environment. Refer to this equipment's data sheet for details about regulatory compliance approvals.

Do not make modifications to this equipment. Any changes or modifications could void the user's authority to operate this equipment.

Modifications have the potential to degrade the level of protection built into this equipment, putting people and property at risk of injury or damage. Those persons making any modifications expose themselves to the penalties arising from proven non-compliance with regulatory requirements and to civil litigation for compensation in respect of consequential damages or injury.

ACCESSORIES

Use only attachments or accessories specified by the manufacturer.

ELECTROMAGNETIC COMPATIBILITY REGULATORY REQUIREMENTS

This equipment meets applicable electromagnetic compatibility (EMC) regulatory requirements. Refer to this equipment's data sheet for details about regulatory compliance approvals. EMC performance is dependent upon the use of correctly shielded cables of good quality for all external connections, except the power source, when installing this equipment.

- Ensure compliance with cable / connector specifications and associated installation instructions were given elsewhere in this manual.

EMC COMPLIANCE STATEMENTS

Where this equipment is subject to USA FCC and / or Industry Canada rules, the following statements apply:

FCC Statement for Class A Equipment

This equipment has been tested and found to comply with the limits for a Class A digital device, pursuant to Part 15 of the FCC Rules. These limits are designed to provide reasonable protection against harmful interference when this equipment is operated in a commercial environment.

This equipment generates, uses, and can radiate radio frequency energy and, if not installed and used in accordance with the instruction manual, may cause harmful interference to radio communications. Operation of this equipment in a residential area is likely to cause harmful interference in which case users will be required to correct the interference at their own expense.

Industry Canada – Industrie Canadienne Statement

This apparatus complies with Canadian ICES-003.

Cet appareil est conforme à la norme NMB-003 du Canada.

CENELEC / CISPR Statement with Respect to Class A Information Technology Equipment

This is a Class A equipment. In a domestic environment this equipment may cause radio interference in which case the user may be required to take adequate measures.

1. Introduction

In this Chapter...

OVERVIEW 2

DESCRIPTION 3

ILLUSTRATIONS 6

BLOCK DIAGRAM 9

Installation and Operation Guide

OVERVIEW

The Quantum18 1.8 GHz Broadband Amplifier Platform includes a variety of RF amplifiers that address the divergent needs of today's broadband networks. All Quantum18 BLE 1.8GHz Line Extenders provide superior two-way performance and reliability combined with a user-friendly layout.

This chapter introduces the Quantum18 BLE 1.8GHz Line Extender and describes its main components, configuration options, and accessories.

PURPOSE

This guide provides instructions for installing, configuring, setting up, and troubleshooting the Quantum18 BLE 1.8GHz Line Extender.

WHO SHOULD USE THIS DOCUMENT

This document is intended for authorized service personnel who have experience working with similar equipment. The service personnel should have the appropriate background and knowledge to complete the procedures described in this document.

QUALIFIED PERSONNEL**WARNING:**

Allow only qualified and skilled personnel to install, operate, maintain, and service this product. Otherwise, personal injury or equipment damage may occur.

Only appropriately qualified and skilled personnel should attempt to install, operate, maintain, and service this product.

SCOPE

This guide discusses the following topics:

- Description of the Quantum18 BLE 1.8GHz Line Extender.
- Installing and configuring the Quantum18 BLE 1.8GHz Line Extender.
- Balancing and setup of line extender forward and reverse signal paths.
- Troubleshooting the Quantum18 BLE 1.8GHz Line Extender.
- Customer support information.
- Descriptions of configuration options and accessories.

EQUIPMENT

The following equipment may be necessary to perform some troubleshooting procedures:

- Digital voltmeter to measure voltages. Longer test lead extensions may be required to reach into shunt base locations in amplifier module
- Spectrum analyzer or a field strength meter to measure RF levels.
- RF Test point probes (Long and Short), to access test points.
- Viavi "ONX-630" meter with "DOCSIS EXPERT" option.

Installation and Operation Guide

DESCRIPTION

The Quantum18 BLE 1.8GHz Line Extender is available in the following amplifier type:

- Automatic Level & Slope Control (ALSC)

The Quantum18 BLE 1.8GHz Line Extender is available in the following reverse path splits:

- 85 / 105 MHz
- 204 / 258 MHz
- 396 / 492 MHz
- 492 / 606 MHz
- 684 / 834 MHz

Characteristics

Quantum18 BLE 1.8GHz Line Extender modules have the following characteristics:

- -20 dB test points, located electrically outside of the diplex filter, provide for testing of forward output signals and reverse input signals without disrupting normal operation.
- Housing lids offered with external test point.
- Direct amplifier module plug-in to the housing provides superior heat sinking.
- Symmetrical housing and modules provide convenient mounting:
- Housings that can be installed facing either toward or away from the street.
- AC circuitry provides 15 A of steady state current capability.
- Surge-resistant circuitry provides improved resistance to high voltage transients.
- Chromated housing protects outdoor equipment in coastal areas and other corrosive environments.
- Compatible with existing legacy B-Line Extender back housing, with ports seizure upgrade.
- Automatic Level & Slope Control (ALSC) to achieve output RF profile
- Network ingress circuitry to support reverse path noise troubleshooting – “wink” switch
- Easy frequency split upgrade with simple plug-in module changes. (Input Diplexer, Output Diplexer, LPFT and HPFT)

Installation and Operation Guide

Power Supply

The DC power supply has the following features:

- Located in housing lid for ease of maintenance.
- AC and DC test points provided on the amplifier module.
- Input Power Voltages: 35 to 90 VAC.
- Selectable AC undervoltage lockout feature
 - The 30-volt lockout is for 60-volt systems
 - The 40 (factory default) and 50-volt lockout positions are for 90-volt systems (field configurable by moving a jumper)
- Not compatible with legacy B-Line Extender power supply.

Input and Output Ports

The Quantum18 BLE 1.8GHz Line Extender has one input and one output port.

Configuration

The Quantum18 BLE 1.8GHz Line Extender is pre-configured with the following:

- Diplex Filters.
- Frequency split dependent High Pass Filter Trim and Low Pass Filter Trim.
- Forward Input Inverse Equalizer (ships with 0dB) and Forward Universal Trim (ships with 0dB).
- 6kV crowbar surge protector, under power module.

Installation and Operation Guide

RF Test Points

There are two (2) RF test points on the Quantum18 BLE 1.8GHz Line Extender module. -20 dB test points, located electrically outside of the diplex filter, provide for testing both input and output signals for both reverse and forward signals without disrupting normal operation.

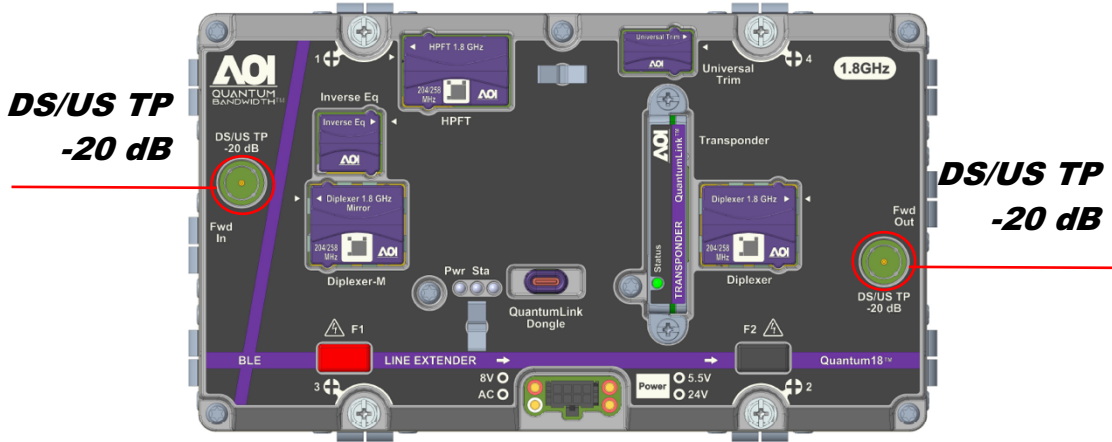

Figure 1- 1: RF Test Points

AC/DC Power Management

The Quantum18 BLE 1.8GHz Line Extender features a new power supply design which accepts the standard range of input voltages. Power distribution from the LE lid is accomplished by the jumper cabling and the shunts used to route power to & through the housing are also located within a package in the lid. The red shunt indicates the input voltage side. Voltage test points are located on the front to the amplifier module next to the jumper connector from the power supply (in lid).

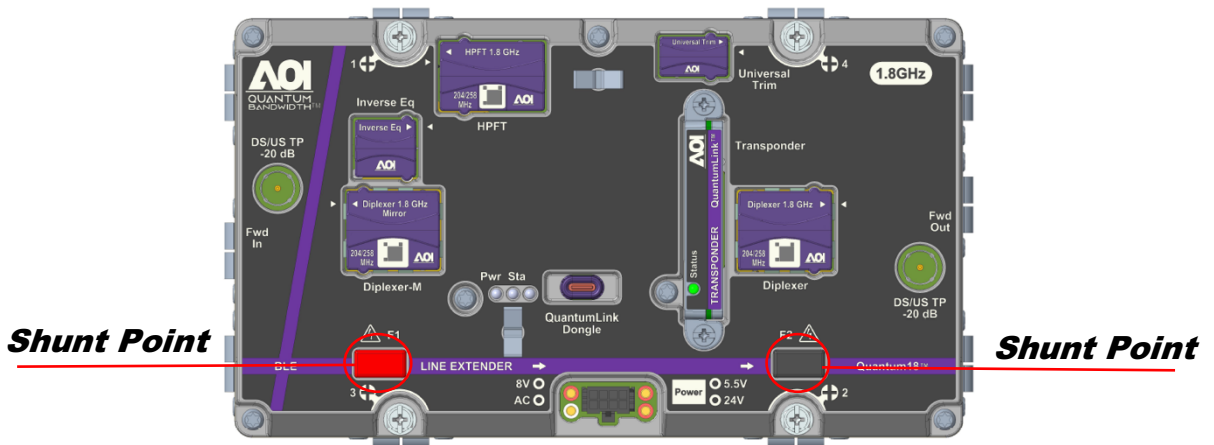

Figure 1- 2: Shunt Locations

Test points for AC and DC voltages are located on the LE amplifier module near the bottom/center. A label shows the appropriate points to probe for the desired readings.

Installation and Operation Guide

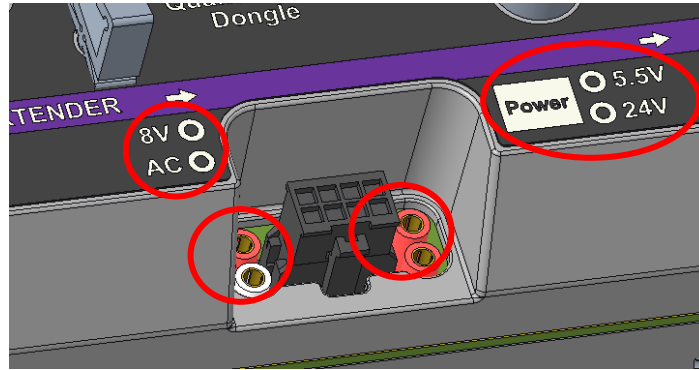

Figure 1-3: AC/DC Test Points

ILLUSTRATIONS

Quantum18 BLE 1.8GHz Line Extender Accessories

The following diagram shows the accessory locations for the Quantum18 BLE 1.8GHz Line Extender.

NOTE: The accessory locations are the same for all Quantum18 BLE 1.8GHz Line Extender models.

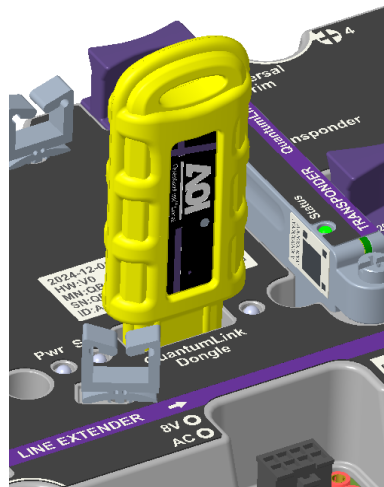

Figure 1-4: QuantumLink Local Wireless Interface

Installation and Operation Guide

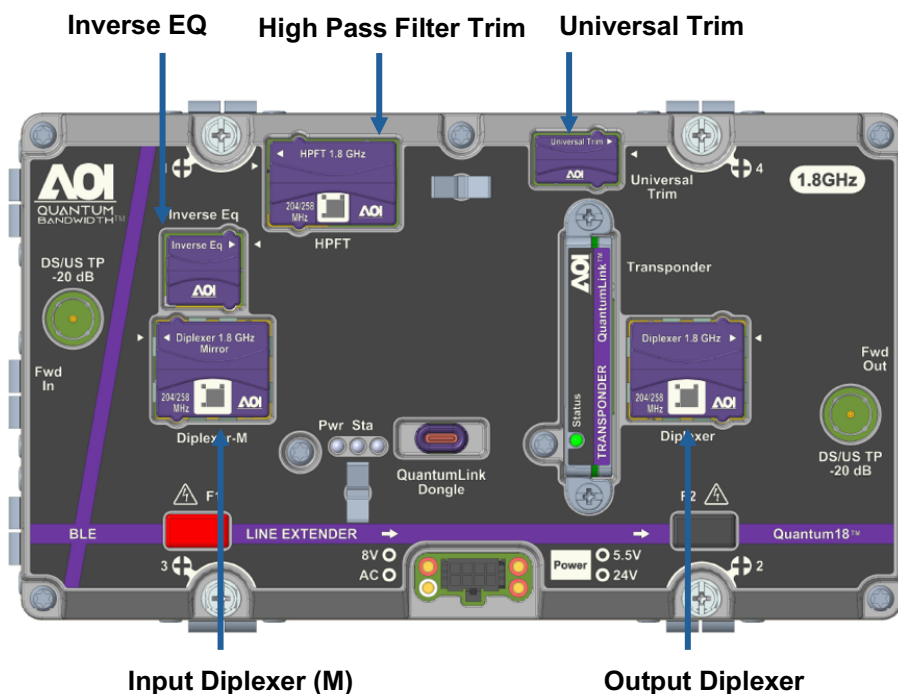

Figure 1- 5: Top Side Accessories

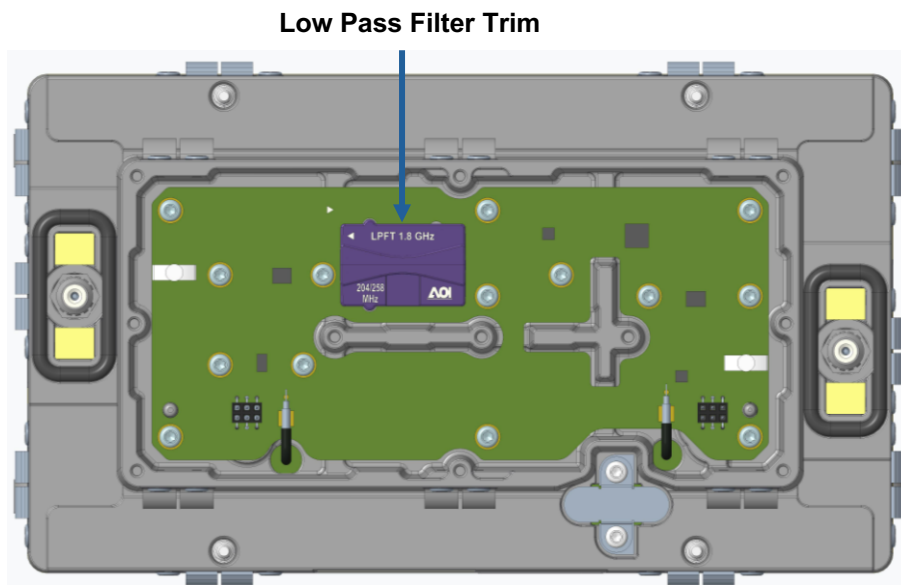

Figure 1- 6: Bottom Side Low Pass Filter Trim

Installation and Operation Guide

Ordering Information

The Quantum18 BLE 1.8GHz Line Extender is available with several forward / reverse bandwidths and user defined AGC pilot frequencies. There are also several customer selectable accessories which will be ordered separately by customers. These accessories may be ordered to complete the field set up of the line extender (Diplex Filters) or spare items (power supplies, surge protectors, etc.). Please refer to the Quantum18 BLE 1.8GHz Line Extender Data Sheet for a full listing of accessories that are available.

NOTE: Please consult with your Account Representative, Customer Service Representative, or System Engineer to determine the best configuration for your particular application.

BLOCK DIAGRAM

The following illustration is a block diagram of the Quantum18 BLE 1.8GHz Line Extender module.

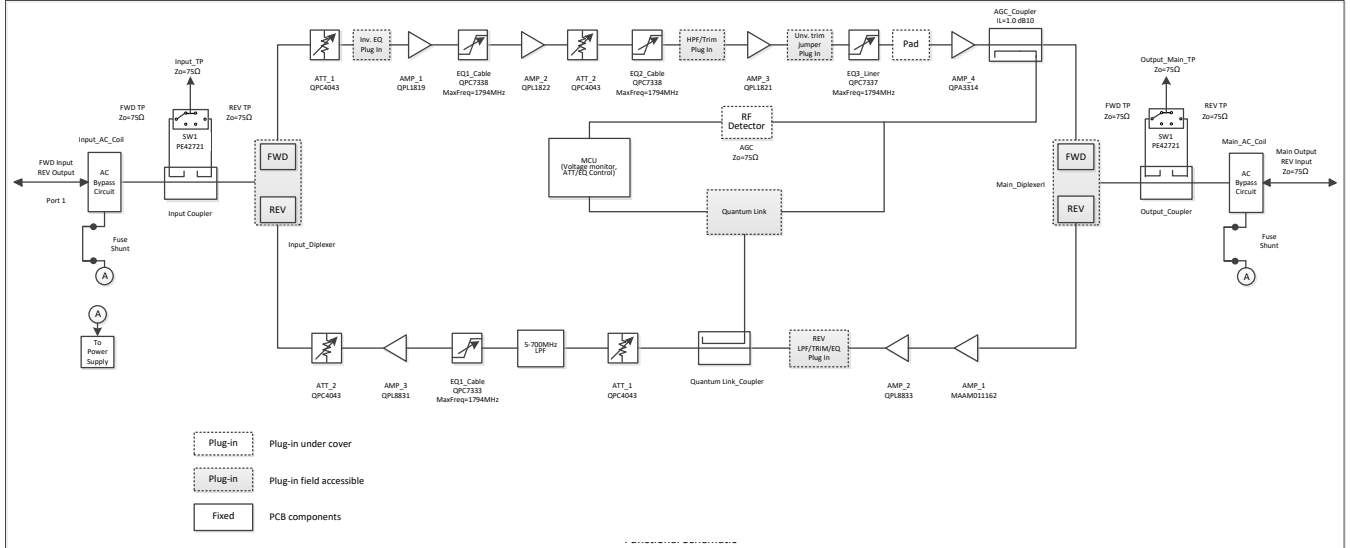

Figure 1- 7: Block Diagram

2. Installation and Configuration

In this Chapter...

- OVERVIEW 11
- BEFORE YOU BEGIN 12
- MODULE AND HOUSING COMPATABILITY 13
- OPENING THE HOUSING..... 14
- UPGRADING EXISTING HOUSING SEIZURES 15
- UPGRADING AN EXISTING HOUSING LID 16
- INSTALLING THE POWER SUPPLY 18
- ATTACHING THE COAXIAL CONNECTORS..... 21
- INSTALLING THE HOUSING 22
- INSTALLING THE AMPLIFIER MODULE 25
- REMOVING THE AMPLIFIER MODULE FROM THE HOUSING 27
- CLOSING THE HOUSING 28

Installation and Operation Guide

OVERVIEW

This chapter provides instructions for installing and configuring the Quantum18 BLE 1.8GHz Line Extender in your cable system.

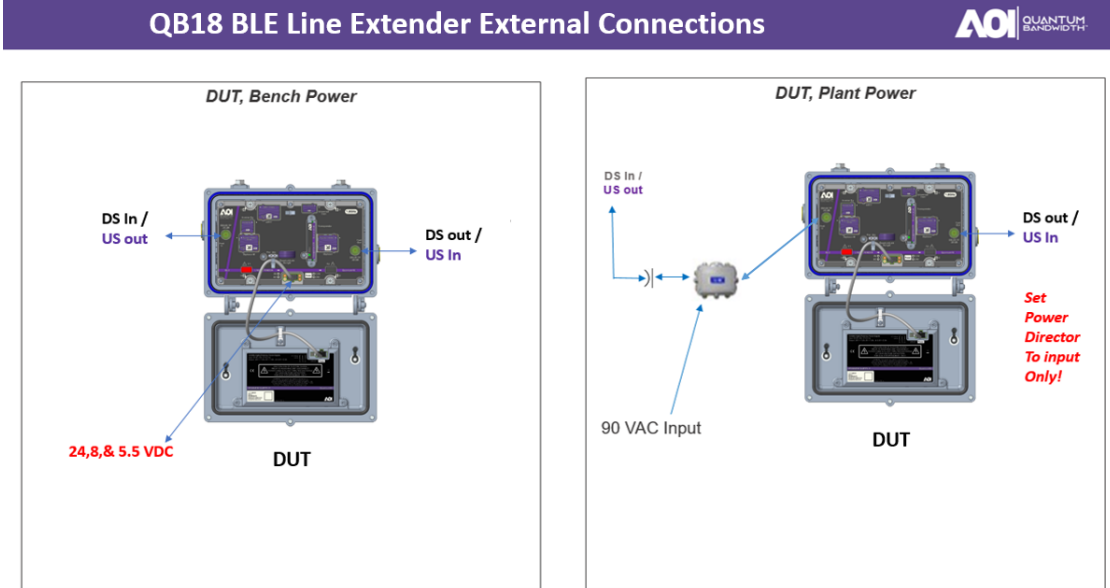

AOI Confidential. Provided under NDA.

Figure 2- 1: External Connections

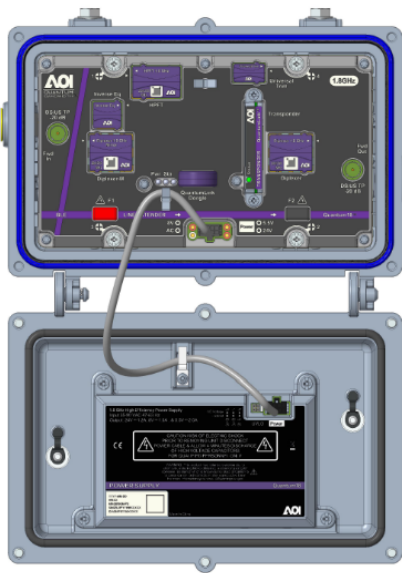

Figure 2- 2: Open Housing



Figure 2- 3: QuantumLink Local Wireless Interface

Installation and Operation Guide

BEFORE YOU BEGIN

The procedures in this chapter assume that you have completed the following:

- Prepared the installation site.
- Located and prepared the coaxial connectors mounted on the cable.



Required Equipment

Before you start, make sure that you have the following equipment:

- 1/2" and 7/16" wrench or nut driver.
- Torque wrench with a 7/16" socket.
- Cross-Recess head No. 2 is recommended.
- T-10 Torx-bit screwdriver
- Heavy-duty wire cutters or snips.

Torque Specifications

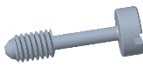
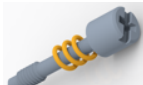
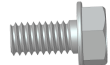
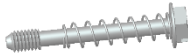
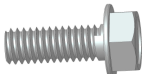
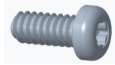
The following table gives the torque specifications for the module:

Fastener	Torque Specification	Illustrations
Transponder Module Securing Screws (Combo Head)	5.3 in-lb to 8 in-lb (0.6 Nm to 0.9 Nm)	
Power Supply Module Securing Screws (Combo Head)	18 in-lb to 20 in-lb (2 Nm to 2.3 Nm)	
Strand Clamp Mounting Bracket Bolts	5 ft-lb to 8 ft-lb (6.8 Nm to 10.8 Nm)	
BLE Amplifier Module Shoulder Screws (Combo Head)	21.2 in-lb to 23 in-lb (2.4 Nm to 2.6 Nm)	
Housing Closure Bolts	5 ft-lb to 7.4 ft-lb (6.8 Nm to 10 Nm)	
Bottom Amplifier Module Cover Screws	10.8 in-lb to 12.2 in-lb (1.2 Nm to 1.4 Nm)	
Test Point Port Plugs	5 ft-lb to 8 ft-lb (6.8 Nm to 10.8 Nm)	

MODULE AND HOUSING COMPATABILITY

Housing Lid

The Quantum18 BLE 1.8GHz Line Extender power supply is compatible with the Quantum18 BLE 1.8GHz Line Extender housing lid only. The power supply will not work with legacy B-Line Extender housing lids.

Housing Base

The Quantum18 BLE 1.8GHz Line Extender amplifier module is compatible with the Quantum18 BLE 1.8GHz Line Extender amplifier housing lid only.

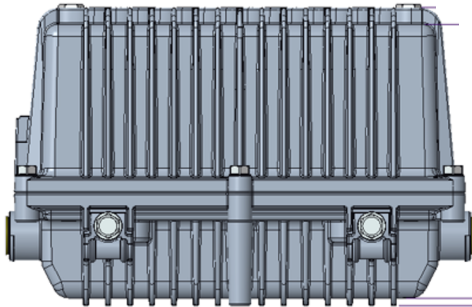

Figure 2- 4: Housing

Housing Dimensions

The diagram shows the dimensions, in inches, of the Quantum18 BLE 1.8GHz Line Extender housing. Use these measurements to calculate clearance requirements for your installation.

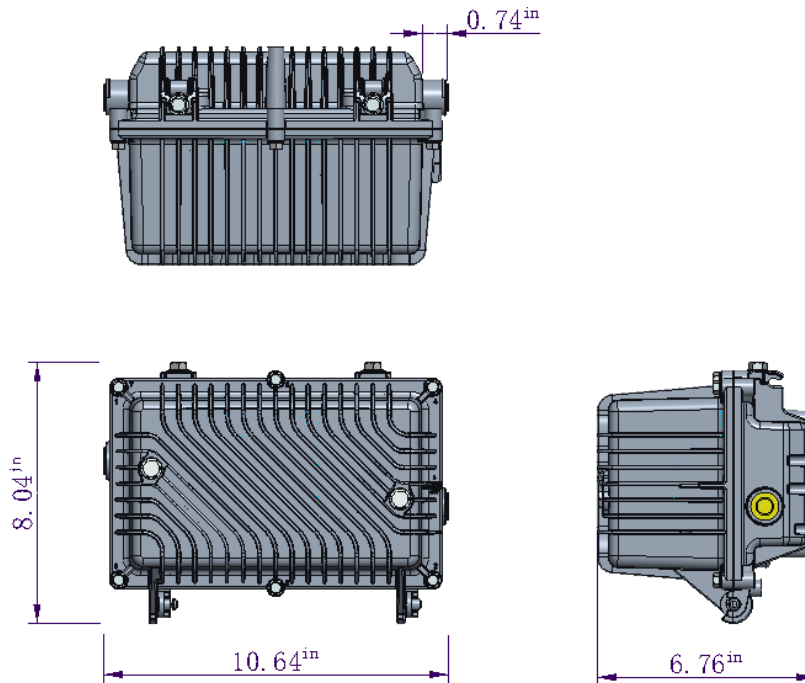

Figure 2- 5: Housing Dimensions

OPENING THE HOUSING

Complete the following steps to open the Quantum18 BLE 1.8GHz Line Extender housing.

IMPORTANT: Before unscrewing the housing bolts, make sure the R Clip near the hinge is in place and secure. The R Clip prevents separation of the lid from the base.

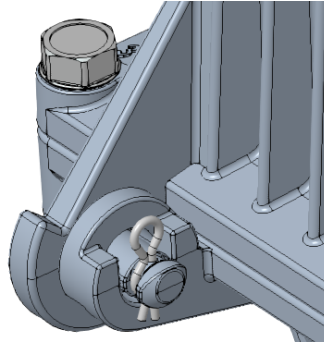

Figure 2- 6: R Clip

1. Unscrew the 7/16" housing closure bolts on the housing lid until they are loose.

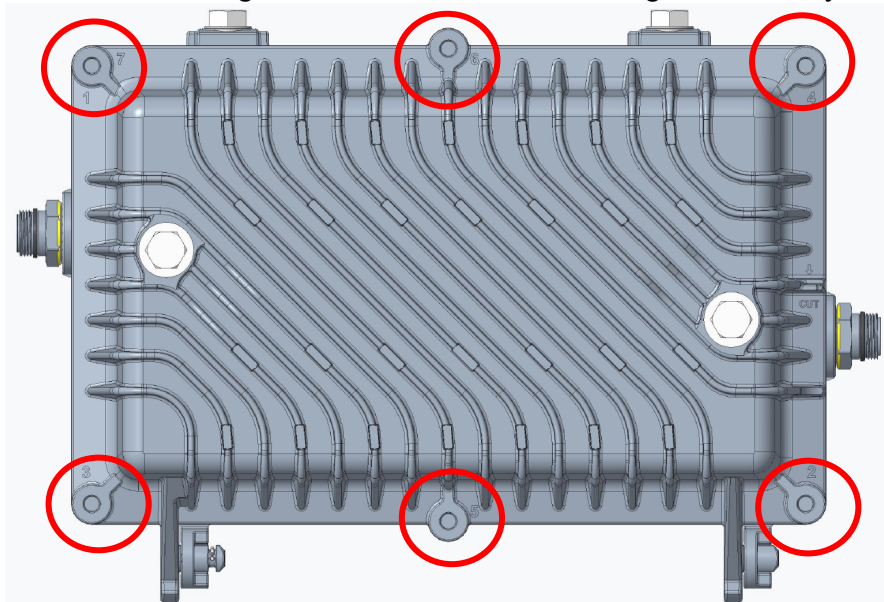

Figure 2- 7: Housing Closure Bolts

2. Open the housing.

NOTE: The closure bolts will remain attached to the housing.

UPGRADING EXISTING HOUSING SEIZURES

The Quantum18 BLE 1.8GHz Line Extender amplifier modules have a higher current-carrying capacity than the legacy B-Line Extender products. If you are replacing a legacy B-Line Extender with a Quantum18 BLE 1.8GHz Line Extender, you will need to upgrade the seizures in the housing base to handle the higher current demands. 15 A seizures are required with 0.063 in. diameter pins and a blue plastic material. These 15 A seizures also support higher temperatures.

NOTE: *The legacy RF connectors, seizures, and anvils are coded black for ease of identification*

To Install the New Housing Seizures

Complete the following steps to upgrade a housing to 15 A current capacity.

IMPORTANT: *The power shunts must be removed before installing the unit into a powered housing. With shunts removed, it reduces the power surge to the components and F-connectors.*



CAUTION:

RF connectors and housing seizure assemblies can be damaged if AC shunt power directors are not removed from the amplifier before installing or removing the amplifier module from the housing. A red shunt indicates the input power port.

1. If an amplifier module is installed in the housing, you must remove it before continuing. Refer to “**Removing the Amplifier Module from the Housing**”.
2. Using a Phillips-head screwdriver, remove the seizures from the housing
3. Using a Philips-head screwdriver, install the new seizure screws from the upgrade kit in the housing.
4. Do one of the following as appropriate:
 - If the coaxial cable is connected to the housing, tighten each seizure screw from 10.6 in-lb to 12.4 in-lb (1.2 Nm to 1.4Nm)
 - If the coaxial cable is not connected to the housing, proceed to “**To Connect the Coaxial Cable Pin Connector to the Housing**”.

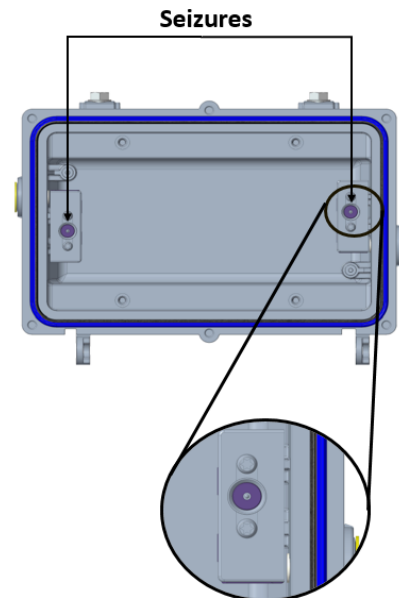

Figure 2- 8: Seizure Locations

UPGRADING AN EXISTING HOUSING LID

The Quantum18 BLE 1.8GHz Line Extender has a new style housing lid that allows easier access to the power supply. If you are replacing a legacy B-Line Extender with a Quantum18 BLE 1.8GHz Line Extender, replace the existing housing lid with a newer housing lid to accommodate the power supply for the Quantum18 BLE 1.8GHz Line Extender.

To Install the New Housing Lid

Complete the following steps to upgrade a housing with the newest housing lid.



CAUTION:

RF connectors and housing seizure assemblies can be damaged if AC shunt power directors are not removed from the amplifier before installing or removing the amplifier module from the housing. A red shunt indicates the input power port.



WARNING:

Before starting this procedure in an aerial or strand mounted application, be sure to clear the area below the housing of all people, and if possible, property.



CAUTION:

In an aerial or strand mounted application, you will need to take steps to ensure that the housing lid does not fall to the ground. See the following recommended procedure.

1. Use a torque wrench to loosen the housing closure bolts on the housing lid.
2. Firmly grasp the housing lid and open it carefully.
3. If new housing lid, depress the housing lid spring load latch near the hinge. The housing lid will now swivel completely open, allowing it to be removed from the housing base. For a legacy housing lid, remove the middle bolt on the hinge side.

IMPORTANT: Place the old housing lid in a safe place until it can be disposed of properly.

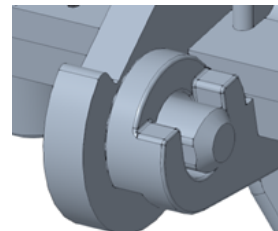
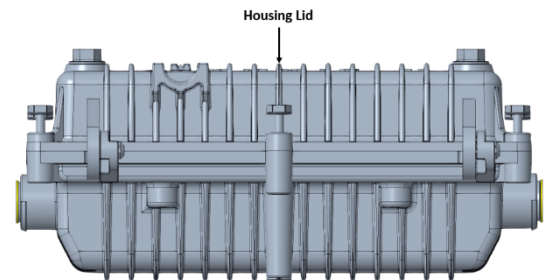

Figure 2- 9: Housing Lid Removal

Installation and Operation Guide

**WARNING:**

It is possible for the housing lid to separate from the housing base and fall, possibly causing injury or damage to persons or property below.

4. Firmly grasp the new Quantum18 housing lid, place it onto the housing bottom, swiveling it into place on the housing hinge, and install the R clip. The lid needs to be fully opened at max angle in order to slide onto the base hinge when the latch is depressed.

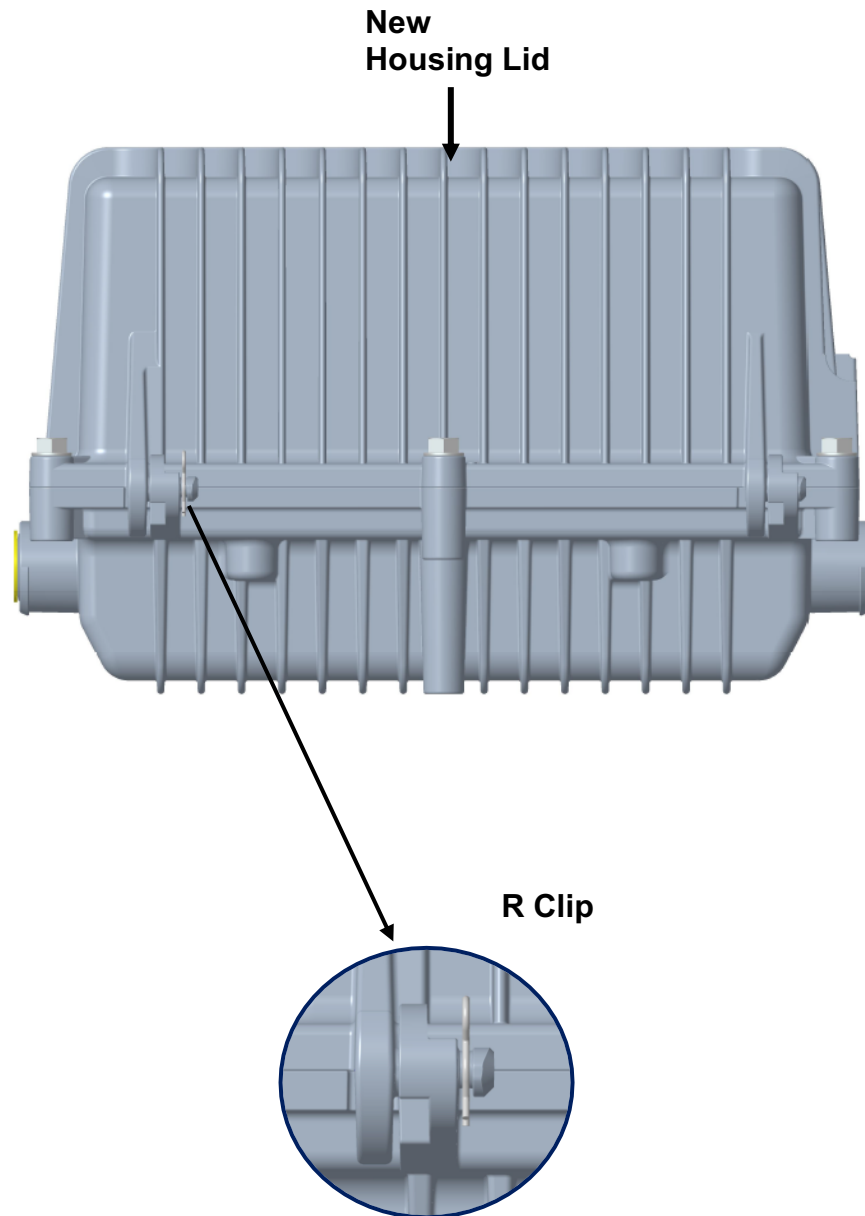

Figure 2- 10: New Housing Lid with R-Clip

INSTALLING THE POWER SUPPLY

IMPORTANT: The AC shunt power directors must be removed before installing the unit. Removal of the AC shunt power directors reduces the power surge to the components and F-connectors.



CAUTION:

RF connectors and housing seizure assemblies can be damaged if AC shunt power directors are not removed from the amplifier before installing or removing the amplifier module from the housing. A red shunt indicates the input power port.

To Install the Power Supply Module

Complete the following steps to install the power supply module:

1. Start with the housing lid open. The power supply is installed in the housing lid.
2. Install the power supply module in the power supply cavity.

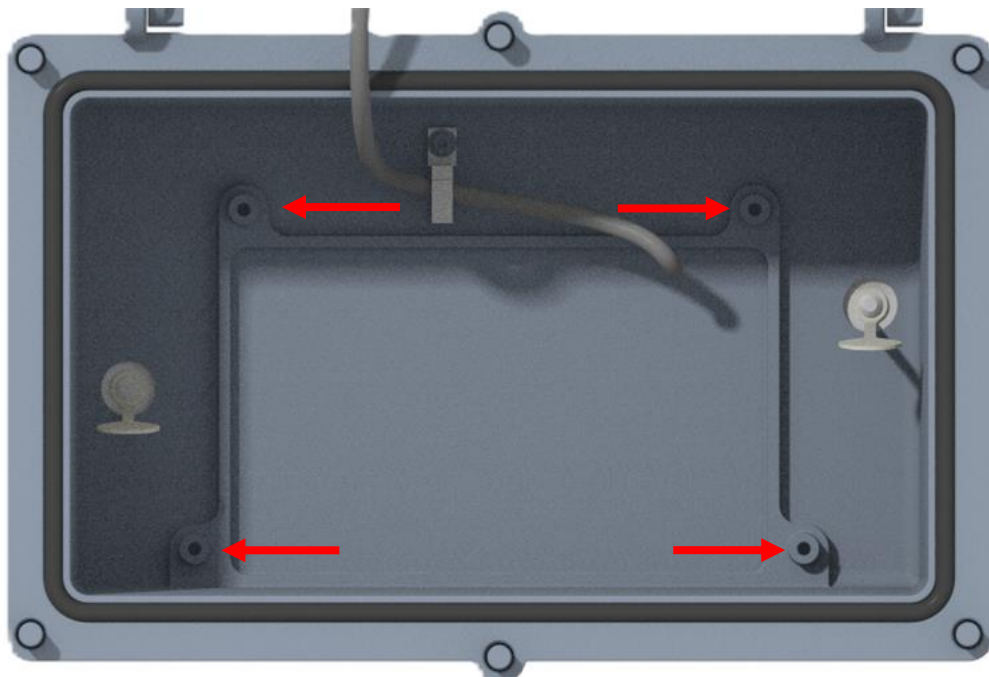

Figure 2- 11: Power Supply Screw Locations

NOTE: There is only one correct way to install the power supply module. Use the metal tabs as a guide to position the power supply module correctly inside the power supply cavity. Be sure that the plastic retaining tabs that secure the test point plugs to the housing lid are not pinched between the power supply and the interior of the housing lid. This will make it difficult to open the test point plug. It is important to push down on the Power Supply Assembly to ensure thermal pad is well seated.

Installation and Operation Guide

3. Tighten the four module screws on the power supply module to 18 in-lb to 20 in-lb (2.0 Nm to 2.3 Nm). Torque the screws in the following sequence – bottom left, bottom right, upper left, upper right.



Figure 2- 12: Power Supply Mounting Screws

4. Attach the 8-pin keyed connector of the power cable and harness to the power supply module.

NOTE: The 8-pin keyed connector can be connected one way only. Be sure that the connector is installed securely to the power supply module connector.

5. Proceed to “To Set the AC Undervoltage Lockout Selector”.

Installation and Operation Guide

To Set the AC Undervoltage Lockout Selector

Set the AC undervoltage lockout selector for your application as specified by your system engineering guidelines.

Undervoltage Lockout Setting	Application
30 V Lockout	60 VAC System
40 V Lockout	90 VAC System
50 V Lockout	90 VAC System

Complete the following steps to set the AC undervoltage lockout selector.

1. Locate the AC undervoltage lockout selector on the power supply in the housing lid.
2. Set the AC undervoltage lockout jumper for your application as illustrated in the following diagram.

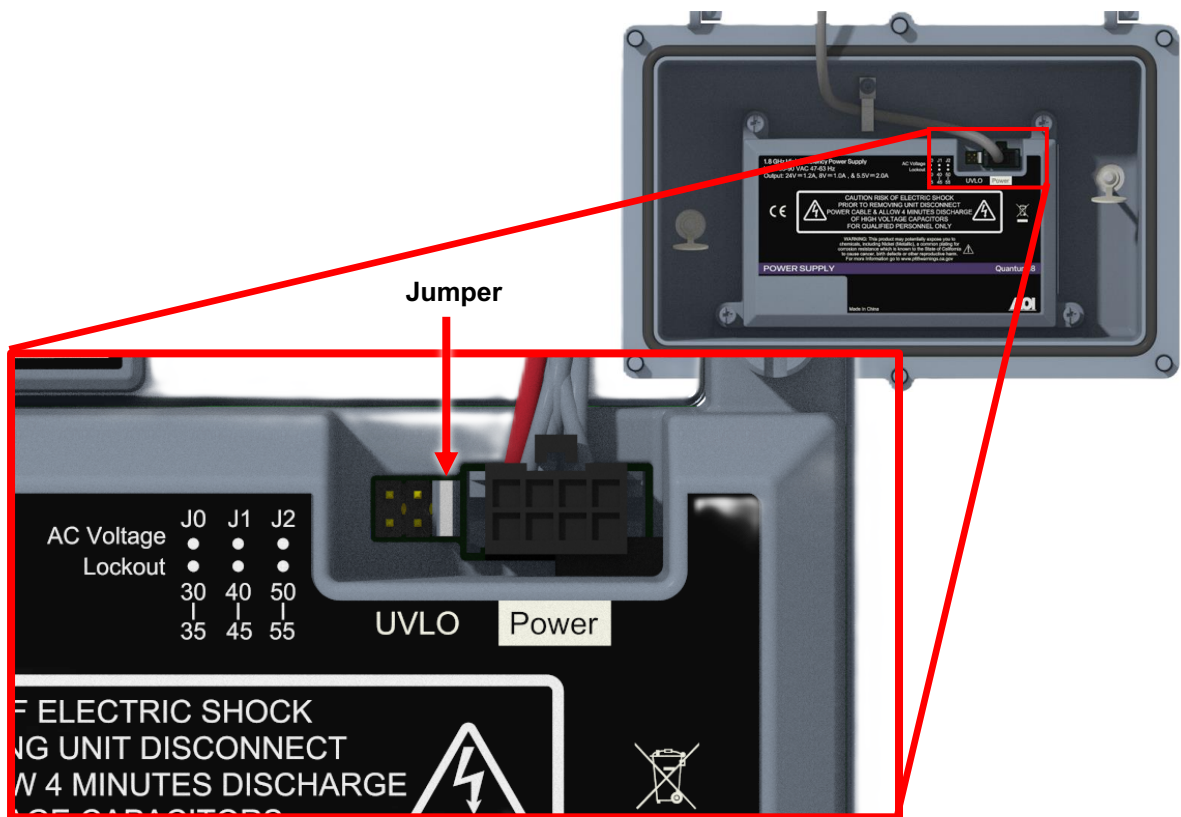

Figure 2- 13: AC Voltage Lockout Jumper

3. Proceed to “Attaching the Coaxial Connectors”.

ATTACHING THE COAXIAL CONNECTORS

To Trim the Center Conductor

The Quantum18 BLE 1.8GHz Line Extender requires pin-type connectors for all RF connections. Standard pin connectors, with pins extending 1.5 in. to 1.58 in (38.2mm to 40.2mm) from the connector shoulder. Before you begin, confirm the following:

IMPORTANT: Do not allow the pin to exceed the 1.58-inch maximum length. We also recommend the cut tip of the pin connector be filed smooth to remove any metal burrs.

Complete the following steps to trim long pins:

1. Place the shoulder and the center conductor pin of the connector against the groove.
2. Trim the center conductor pin extending past the groove on the housing lid.

The following diagram shows a visual guide of the center conductor trim length.

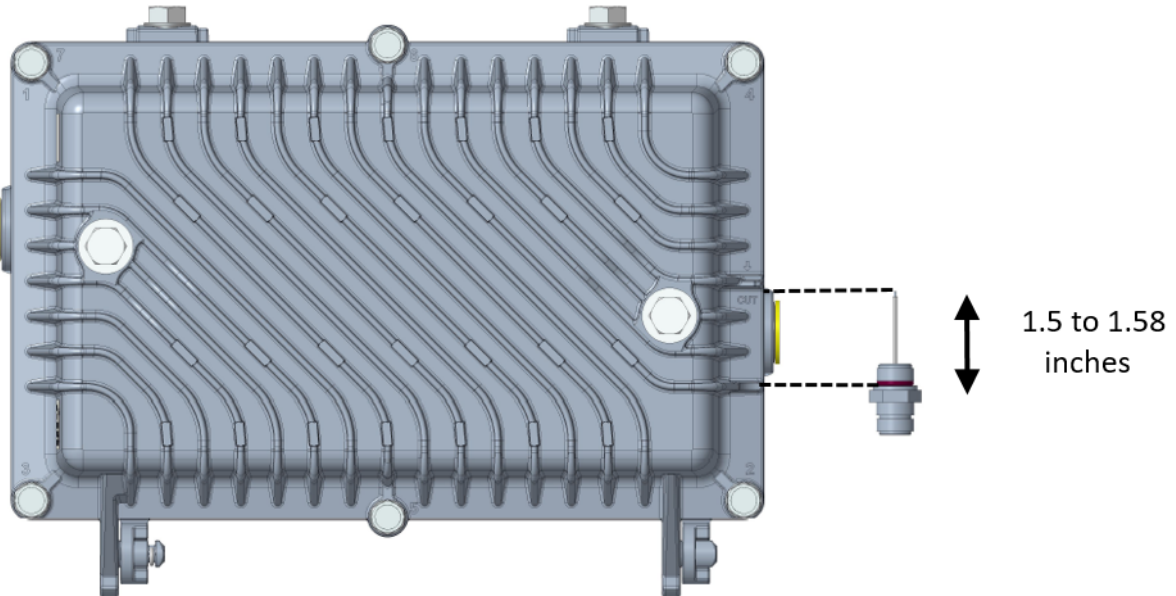

Figure 2- 14: Coaxial Cut Length

To Connect the Coaxial Cable Pin Connector to the Housing

Complete the following steps to connect the coaxial cable pin connector to the Quantum18 BLE 1.8GHz Line Extender housing:

1. Begin this procedure with the housing open. Refer to “**Opening the Housing**”.
2. If the coaxial cable connector center pin extends more than the length specified in “**To Trim the Center Conductor**”, trim the pin with heavy-duty wire cutters.
3. Insert the appropriate coaxial connector into the housing at the desired housing port.
4. Tighten the coaxial cable connector to housing entry port to 20 – 25 ft-lb (27 – 33.9 N-m).
5. Repeat steps 2 through 5 for the other RF port.
6. Proceed to “**Installing the Housing**”.

INSTALLING THE HOUSING

The following procedures detail how to install the Quantum18 BLE 1.8GHz Line Extender housing on a strand (aerial) or in a pedestal.

To Install the Housing on a Strand (Aerial)

Complete the following steps to install the housing on a strand (aerial). The housing does not need to be opened for strand installation.

IMPORTANT: *The minimum strand diameter should be 5/16”.*



CAUTION:

Be aware of the size and weight of the housing while strand mounting.

Ensure that the strand can safely support the weight of the housing.

1. Loosen the strand clamp bolts.
2. Lift the housing into proper position on the strand.
3. Slip the strand clamps over the strand and finger-tighten the clamp bolts. This allows additional movement of the housing as needed.
4. Move the housing as needed to install the coaxial cable and connectors. See the diagrams below for examples.
5. Ensure proper grounding of the housing meets industry standards and local code requirements (NESC, etc.)

Installation and Operation Guide

Signal Flow From Left to Right

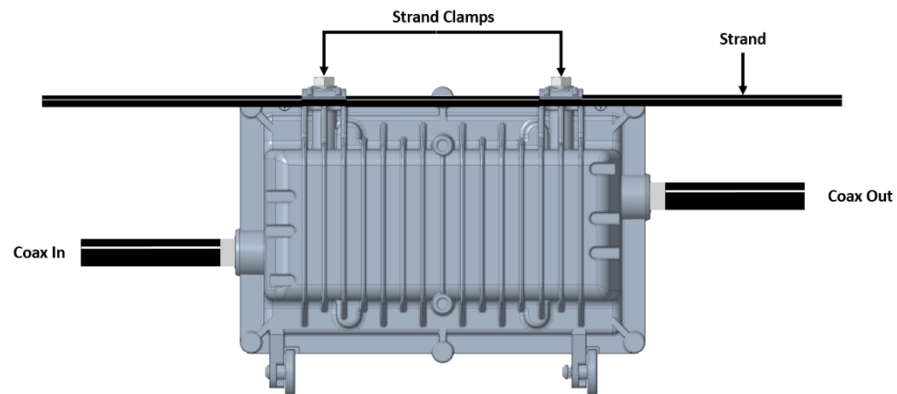

Figure 2- 15: Signal Flow from Left to Right

Signal Flow From Right to Left

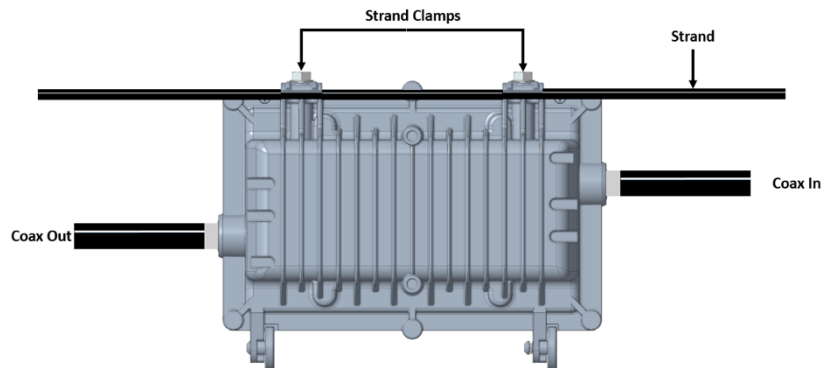

Figure 2- 16: Signal Flow from Right to Left

NOTE: Coax In may be switched with the Coax Out if you reverse the line extender module and feed the signal from right to left.

6. Using a 1/2" torque wrench, tighten the strand clamp bolts from 5 ft-lb to 8 ft-lb (6.8 Nm to 10.8 Nm). Make sure there is good mechanical contact between the strand and the housing.

NOTE: A slight tilt of the face of the housing is normal. Cable tension will cause the housing to hang more closely to vertical.

7. Connect the coaxial cable to the pin connector according to connector manufacturer specifications.
8. Proceed to "Installing the Amplifier Module"

Installation and Operation Guide

To Install the Housing in a Pedestal

Complete the following steps to install the Quantum18 BLE 1.8GHz Line Extender in a pedestal:

1. Remove the cover of the pedestal.
2. Remove the mechanical bolts from the strand clamps and set the bolts and strand clamps aside.
3. Position the housing in the pedestal frame as shown in the following illustration. Line up the self-tapping bolt holes on the bottom of the housing with the mounting holes on the bracket.

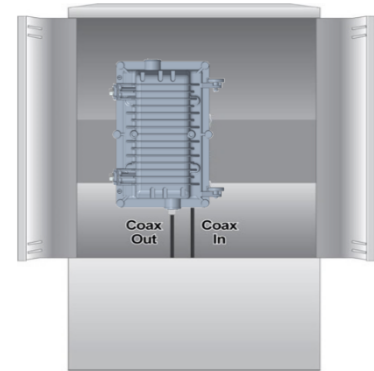

Figure 2- 17: Housing Mounted in a Pedestal

NOTE: *The housing mounts to the bracket provided by the pedestal manufacturer.*

4. Secure the housing to the bracket by using the bolts that you removed in Step 2. Use the strand clamps as spacers if necessary. Ensure proper grounding of the housing meets industry standards and local code requirements (NESC, etc.)
5. Torque the bolts from 8 ft-lb to 10 ft-lb (10.8 Nm to 13.6 Nm).
6. Connect the coaxial cable to the pin connector according to connector manufacturer specifications.
7. Proceed to “**Installing the Amplifier Module**”.

INSTALLING THE AMPLIFIER MODULE

The Quantum18 BLE 1.8GHz Line Extender amplifier module plugs into the strand-mounted or pedestal-mounted (bottom) of the housing via RF connectors on the bottom side of the module.

To Install the Amplifier Module

Complete the following steps to install the Quantum18 BLE 1.8GHz Line Extender amplifier module:

1. Perform the following if you are working with a Quantum18 BLE 1.8GHz Line Extender where AC is present.



CAUTION:

RF connectors and housing seizure assemblies can be damaged if shunts are not removed from the line extender before installing or removing the line extender module from the housing. A red shunt indicates the input power port.

- Install the AC shunt power directors in the amplifier **after** you install the amplifier module in the housing.
 - Remove the AC shunt power directors from the amplifier **before** you remove the amplifier module from the housing.
2. Orient the Quantum18 BLE 1.8GHz Line Extender amplifier module so the Input and Main output ports (the locations of which are stamped on the module cover) are in the proper corners for your installation.
 3. Line up the RF connectors on the Quantum18 BLE 1.8GHz Line Extender amplifier module and the housing, and then push the Quantum18 BLE 1.8GHz Line Extender amplifier module into the housing.
 4. Secure the Quantum18 BLE 1.8GHz Line Extender amplifier module to the housing by tightening the four in-line extender module retainer screws. Tighten combo head screws to 18 in-lb to 20 in-lb (2.0 Nm to 2.25 Nm). See the following illustration for the location of the retainer screws.

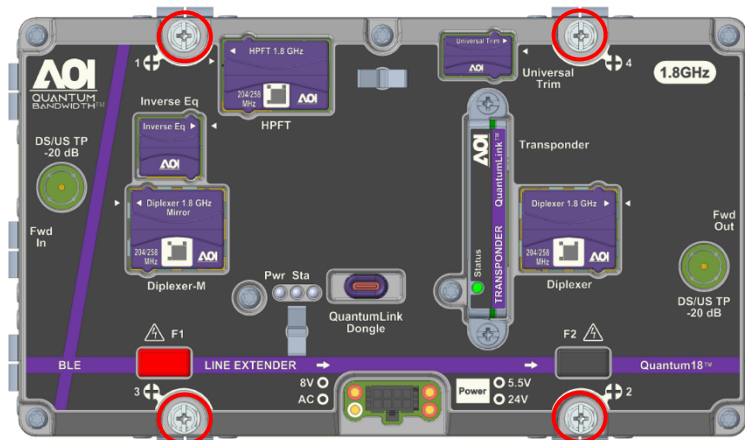

Figure 2- 18: Retainer Screw Location

Installation and Operation Guide

5. Snap the power cable harness into place in the holes provided.
6. Attach the 8-pin keyed connector of the power harness to the Quantum19 BLE 1.8GHz Line Extender amplifier module.

NOTE: The 8-pin connector can be connected one way only. Confirm that the connector installs securely to the amplifier module.

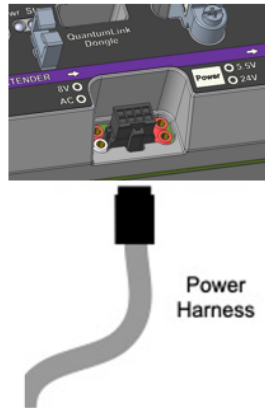

Figure 2- 19: Power Harness

7. Install the shunts into the sockets to route the AC into and through the module to downstream active devices. They are in a plastic pocket attached to the amplifier cover. A red shunt indicates the input power port.

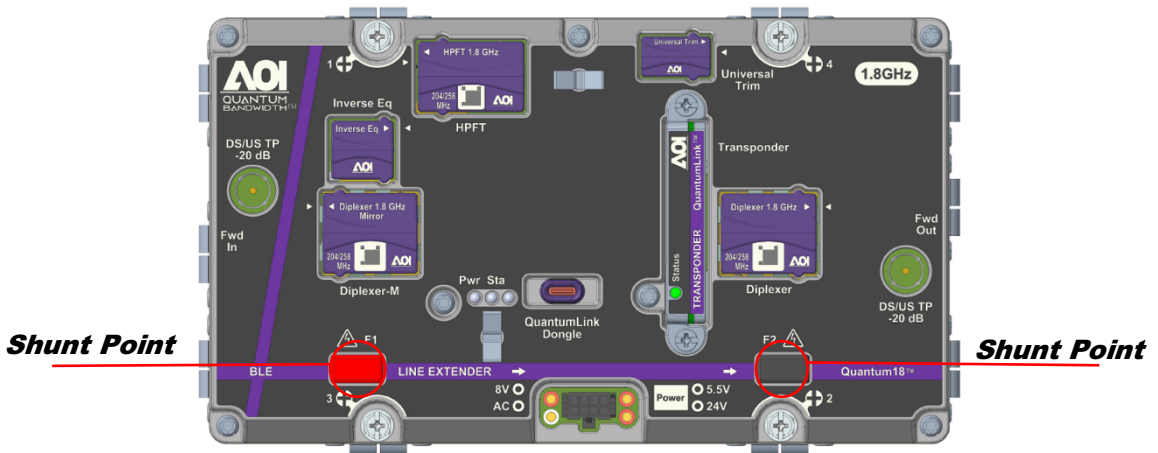

Figure 2- 20: Shunt Locations

REMOVING THE AMPLIFIER MODULE FROM THE HOUSING

To Remove the Amplifier Module

Complete the following steps to remove the amplifier module:

1. Open the housing. Refer to “**Opening the Housing**”.
2. Remove the AC shunt power directors from the amplifier before you remove the amplifier module from the housing. A **red** shunt indicates the input power port.
3. Unplug the 8-pin keyed connector of the power cable harness from the amplifier module.
4. Remove the power cable harness from the white plastic retainer clip.
5. Using a cross-recess driver No. 2, loosen the four module retaining screws.
6. Remove the amplifier module from its housing.

**CAUTION:**

Avoid personal injury and damage to the amplifier module. Make sure that you place the amplifier module on a secure surface.

CLOSING THE HOUSING

To close the Housing

Complete the following steps to close the housing:



CAUTION:

Avoid moisture damage and RF leakage! Follow the procedure exactly as shown below to ensure a proper seal.

1. Inspect the housing gasket and all mating surfaces. Wipe off any excess dirt and debris.
2. Close the housing and finger-tighten all closure bolts.
3. Use a torque wrench with a 7/16" socket to tighten each closure bolt from 5 ft-lb to 7.4 ft-lb (6.8 Nm to 10 Nm) each.
4. The tightening sequence is shown in the following **Torquing Sequence** section. Follow the numbered sequence to tighten the closure bolts.

Torquing Sequence

The following diagram shows the proper torquing sequence for the housing closure bolts.

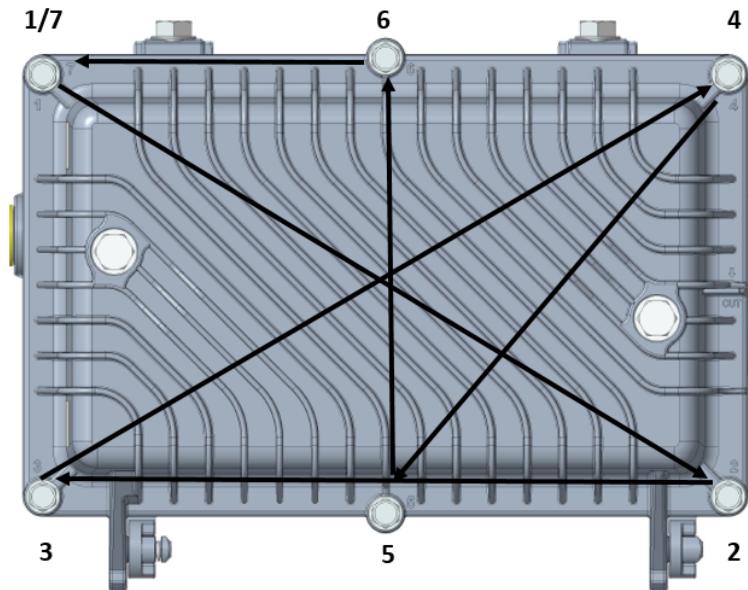

Figure 2- 21: Torquing Sequence

3. Balancing and Setup

In this Chapter...

INTRODUCTION	30
PREPARING FOR AMPLIFIER SET-UP.....	31
VERIFY/UPDATE AMPLIFIER INFORMATION	33
VERIFY/UPDATE AMPLIFIER CONFIGURATION	34
LOCATION DATA.....	35
DOWNSTREAM PROFILE CONFIGURATION	36
DOWNSTREAM AUTO ALIGNMENT	37
DOWNSTREAM MANUAL ALIGNMENT.....	38
VIEW DOWNSTREAM SPECTRUM	39
UPSTREAM ALIGNMENT.....	40
UPSTREAM ALIGNMENT...continued	41
CASCADE ALSC ACTIVATION	42
TEST POINTS	43
DIAGNOSTICS.....	44

INTRODUCTION

This section provides instructions for the initial setup and balancing methods for the Quantum18 BLE 1.8GHz Line Extender. Troubleshooting and Diagnostics is also covered.

NOTE: *This amplifier is designed to be auto-aligning and requires no in-field adjustments to its RF levels.*

During the initial install, the steps outlined will provide steps to identify the Quantum18 BLE 1.8GHz Line Extender and its location in the network. Following steps will focus on the downstream and upstream initial setup using an auto-alignment or manual process. During the auto-alignment process the steps will allow the amplifier to automatically adjust itself to provide unity gain within the RF design of the network, the Quantum18 BLE 1.8GHz Line Extender is being installed. This is achieved without the need of field level measurements, that are typically required during an RF network setup.

The technician will establish a Bluetooth connection to the amplifier to perform the activations process via the QuantumLink Local Wireless Interface that is plugged into the Quantum18 BLE 1.8GHz Line Extender amplifier module. All Quantum18 BLE 1.8GHz Line Extender are expected to have identical RF output levels with the varying RF inputs electronically adjusted for optimal performance. There is no field-level adjustment of levels (downstream & upstream) once the initial installation process is completed.

These procedures are performed once the amplifier has been spliced into the outside plant in accordance with the system operator's typical field practices. An Android or iOS device is used to establish a Bluetooth connection with the QuantumLink Local Wireless Interface plugged into the Quantum18 BLE 1.8GHz Line Extender amplifier module (shown below).

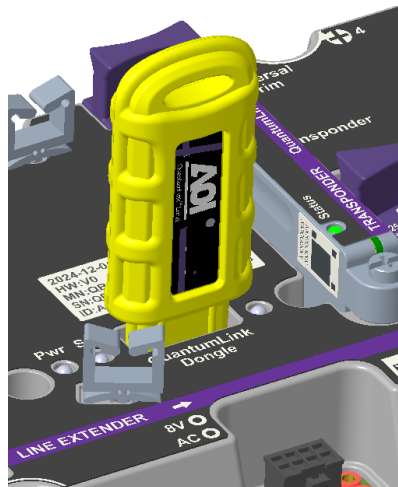

Figure 3- 1: QuantumLink Local Wireless Interface installed in an BLE

PREPARING FOR AMPLIFIER SET-UP

- Locate and Initiate QuantumLink Local Mobile Application on the Technician's portable device (Tablet/Handheld), see Figure 3-2.
- Insert the QuantumLink Local Wireless Interface in the Quantum18 BLE 1.8GHz Line Extender amplifier module as shown above. Figure 3-1.
- Establish point to point connections via Bluetooth between the technician's portable device and the QuantumLink Local Wireless Interface by using "Select Device" drop down in the QuantumLink Local Mobile Application menu to select the proper QuantumLink Local Wireless Interface, see Figure 3-3.
- Log into the QuantumLink Local Mobile Application, using an accepted username and password, see Figure 3-4.

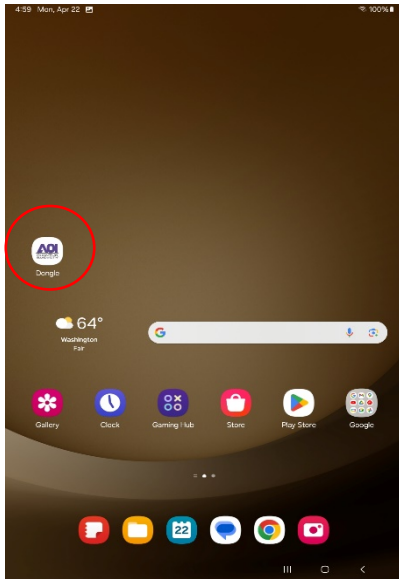

Figure 3- 2: Home Screen

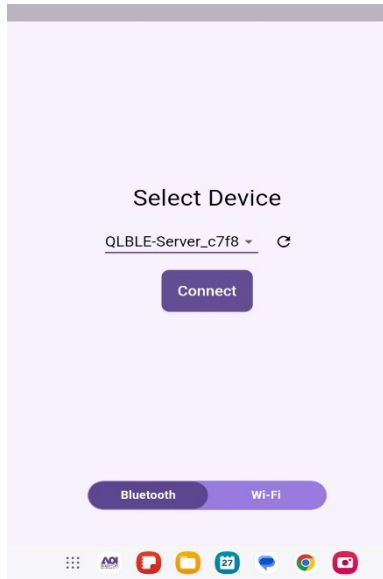

Figure 3- 3: Device Selection

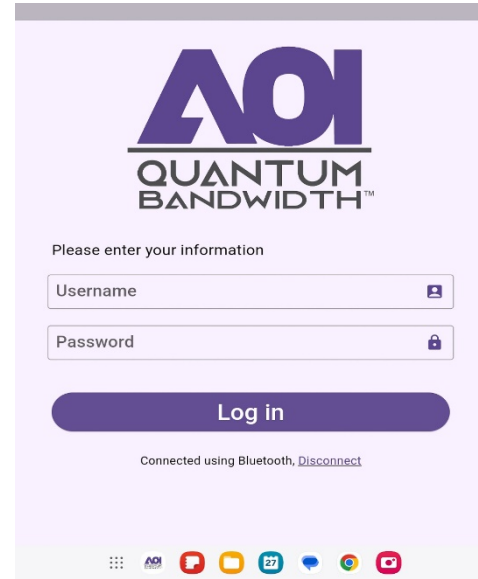
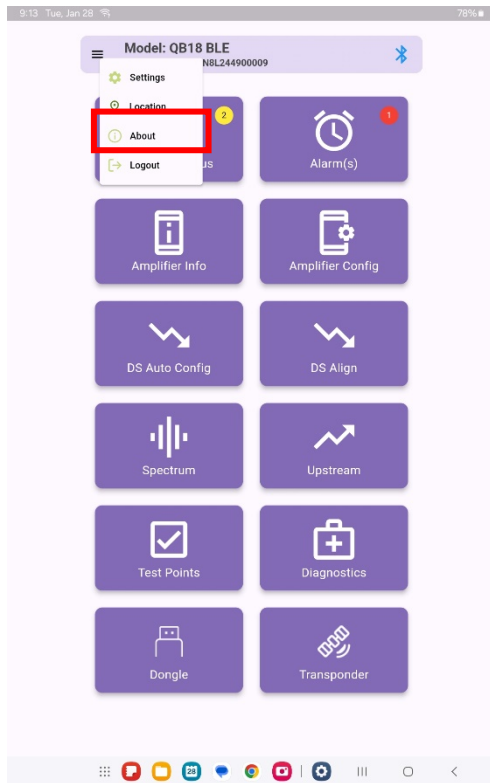

Figure 3- 4: User Login

VERIFY LATEST FIRMWARE AND MAC ADDRESS

- From the Main Menu located in the top left section of the QuantumLink Local Mobile Application, select the menu, then select “About”. Figure 3-5
- A new screen appears showing the present version of the QuantumLink Local Wireless Interface firmware, the QuantumLink Local Mobile Application. Version, and the QuantumLink Local Wireless Interface Mac Address. Figure 3-6

**Figure 3- 5: About Menu****Figure 3- 6: About Information**

VERIFY/UPDATE AMPLIFIER INFORMATION

- Select the “Amplifier Info Tile” to obtain the data specific to this Amplifier. Figure 3-7.
- See below for Amplifier Info available. Device Alias and Device Description are not initially populated, to update, select and update to a desired Alias and Device Description. Select return to main menu.

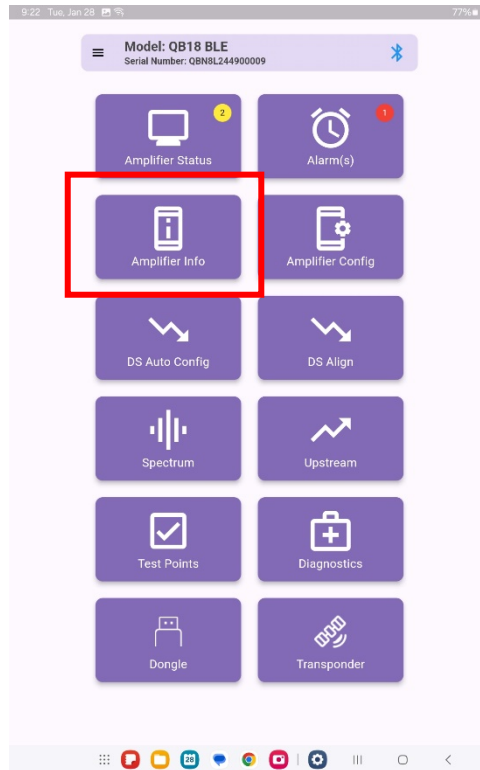

Figure 3- 7: Amplifier Info Tile

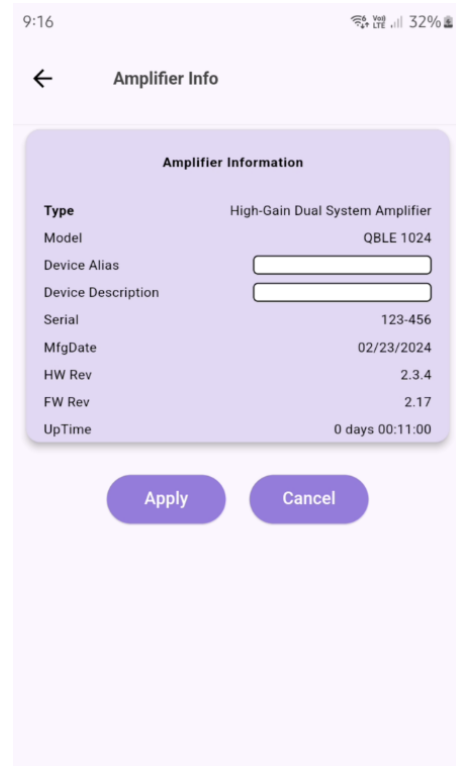

Figure 3- 8: Amplifier Info Details

VERIFY/UPDATE AMPLIFIER CONFIGURATION

- Select the Amplifier Config Tile Figure 3-9.:
 - Diplex Filter – Verify correct frequency split is displayed. If not select proper frequency split from frequency split drop down. Figure 3-10
 - ALSC – Is set to default to OFF during initial configuration. Keep in the OFF position until the DS/US alignment is completed. For instructions on how to turn on ALSC, refer to the relevant section later in the I&O guide. Figure 3-10
 - Operational Mode – Is default to 1.8GHz. To change to 1.2GHz, select the “1.2GHz”. Figure 3-10
 - The active bank is indicated with a green check mark, signifying the memory location for the amplifier’s active firmware version. If an update to the amplifier firmware is necessary, the "Update" option should be used. Please refer to the Amplifier Firmware Update procedure for detailed instructions. Figure 3-11

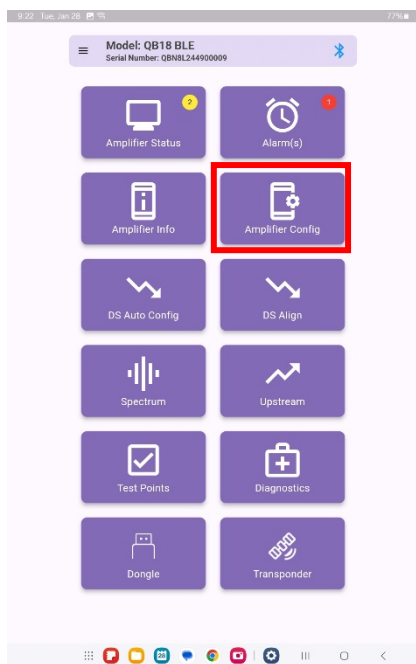

Figure 3- 9: Amplifier Config Tile

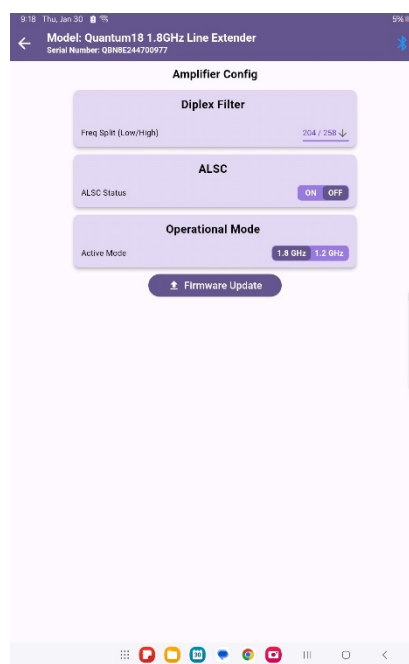

Figure 3- 10: Amplifier Configuration Details

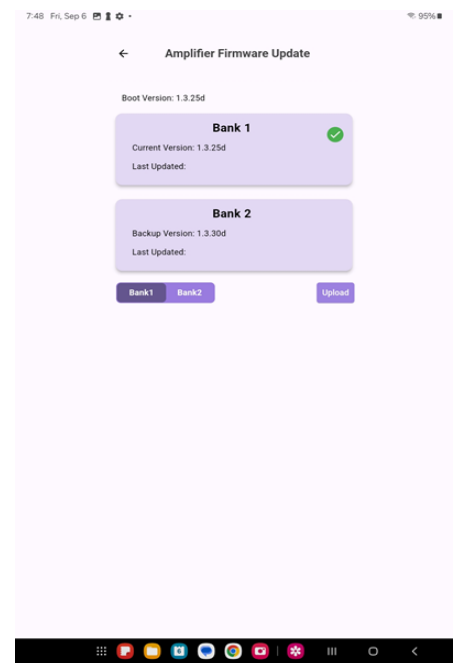

Figure 3- 11: Amplifier Firmware Update

LOCATION DATA

The specific geo-location of the device is either manually or automatically written into the device's memory. The portable device's GPS coordinates, Google Maps, and manual Long/Lat entry are available options. Location: Figure 3-12.

- To automatically set the geo-location with a portable device, select the location icon from the drop-down menu of the Home screen, see Figure 3-12.
- Next select, Edit location at the bottom of the screen, see Figure 3-13.
- Finally select, the "My Location" icon on the screen and then press save location afterwards. See Figure 3-14.

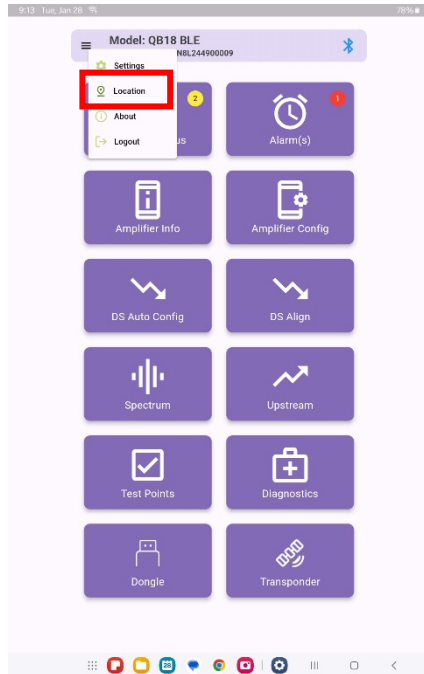

Figure 3- 12: Location Menu

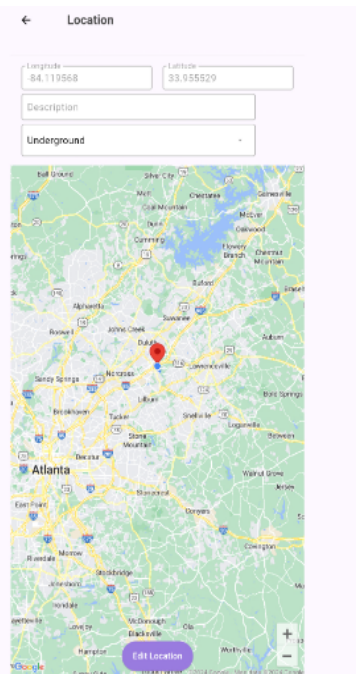

Figure 3- 13: Edit Location

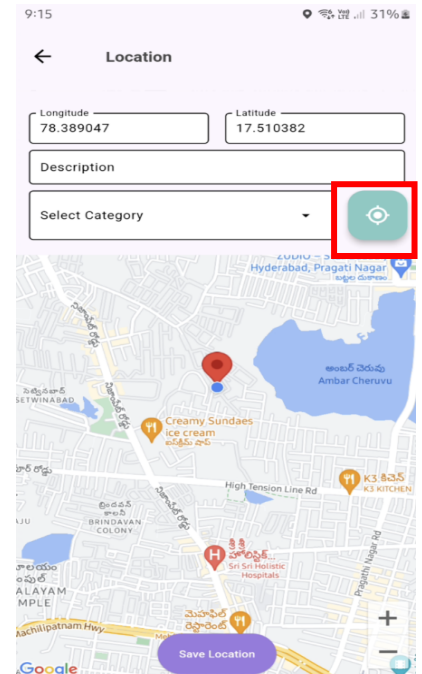

Figure 3- 14: Set Location

DOWNSTREAM PROFILE CONFIGURATION

Select DS Auto Config Tile from the Main Menu. Figure 3-15.

The default factory Downstream Configuration Parameters are displayed here.

- Auto Config – Update frequency settings and power levels as defined for this Amplifier's Profile
- ALSC – No action required, for information only
- Auto Align Marker Pilots – No action required, for information only

After updates are made select Apply to save changes to the Amplifiers settings, see Figure 3-16.

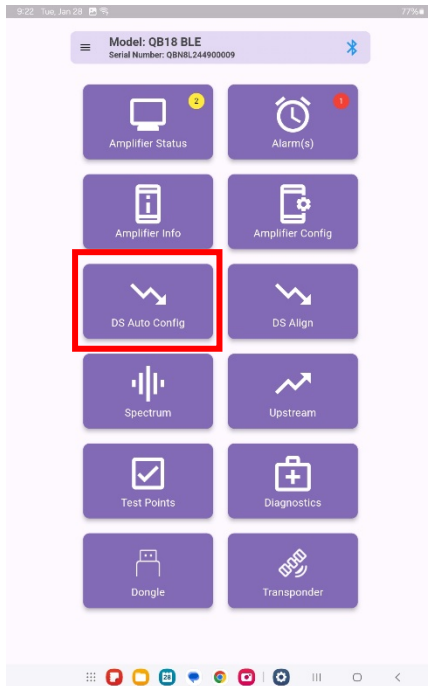

Figure 3- 15: DS Auto Config Tile

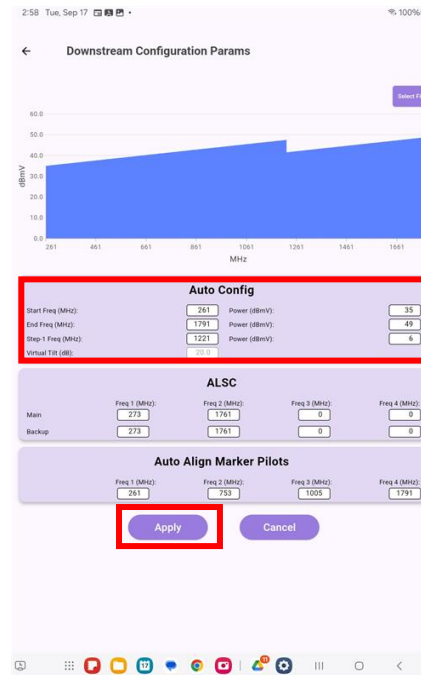

Figure 3- 16: Auto Config Details and Apply

DOWNSTREAM AUTO ALIGNMENT

The Downstream (DS) auto-alignment is performed after the pilot carrier frequencies are confirmed and properly stored in the amplifier, during the Downstream Profile Configuration section. Figure 3-17.

- Select DS Align Tile from the Main Menu
- Select Auto and then select Start Downstream Alignment to begin Auto Alignment. Figure 3-18.

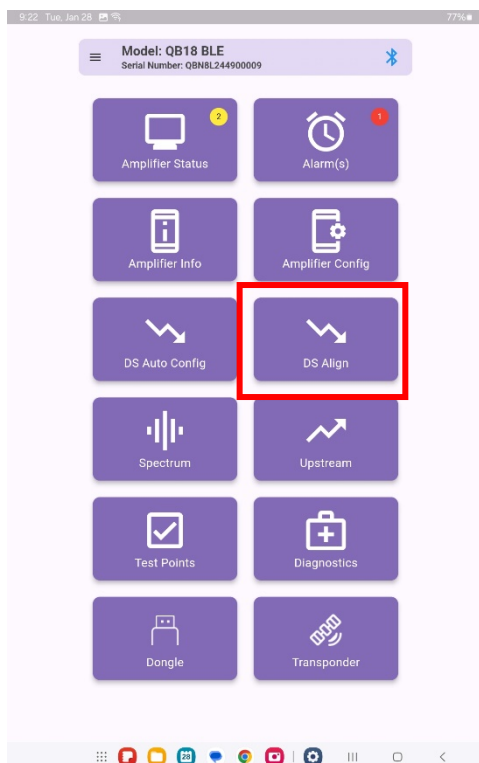

Figure 3- 17: DS Align Tile



Figure 3- 18: Auto Alignment Button

DOWNSTREAM MANUAL ALIGNMENT

The Downstream (DS) manual alignment must be performed after an Auto-alignment has been completed. The technician reviews how relative changes are made by dynamically changing the Pilot Frequency Power Levels. This process is described below. ***This is typically not be required under normal field operational conditions.***



Figure 3- 19: Downstream Alignment

1. Select Manual
2. Adjust the different values one at a time to verify the Level Marker frequency levels match the Ref. Marker frequency levels.
3. The check box to the right of the +/- is pressed to apply the changes but are not saved.
4. After pressing the check box and selecting the Save Configuration are the changes saved to the amplifier.
5. Should the results be undesirable, simply press the "Revert" key to return to factory pre-set which will allow DS-Auto Align to override Manual activity.

VIEW DOWNSTREAM SPECTRUM

The Spectrum Tile, Figure 3-20, is selected to verify the downstream RF configuration has been successfully completed. This process requires approximately 30 seconds to scan the output downstream RF response.

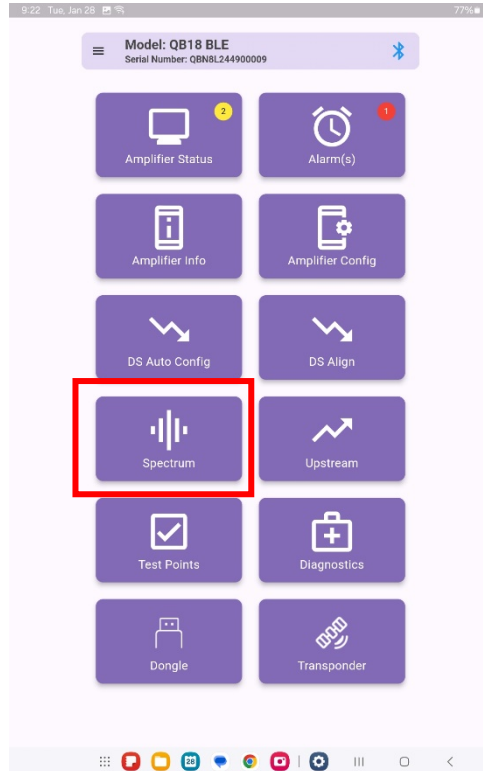

Figure 3- 20: Spectrum Tile



Figure 3- 21: Spectrum Capture

UPSTREAM ALIGNMENT

Upon completion of the Downstream setup and balancing for a cascade of amplifiers, the Upstream alignment must begin with the last amplifier in the cascade. Upstream alignment can be performed in Auto or Manual modes.

- Select the Upstream Tile – Figure 3-22.
- For Auto Alignment - Select Start Auto, see Figure 3-23
- After Auto Alignment is successfully completed a pop-up window appears requesting to Save or Revert (redo) the alignment.

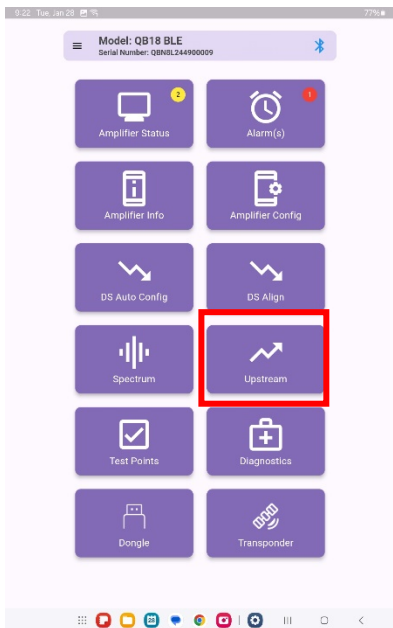

Figure 3- 22: Upstream Tile

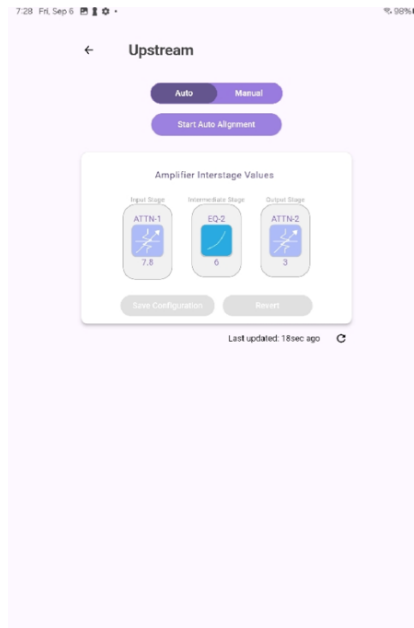

Figure 3- 23: Auto Alignment

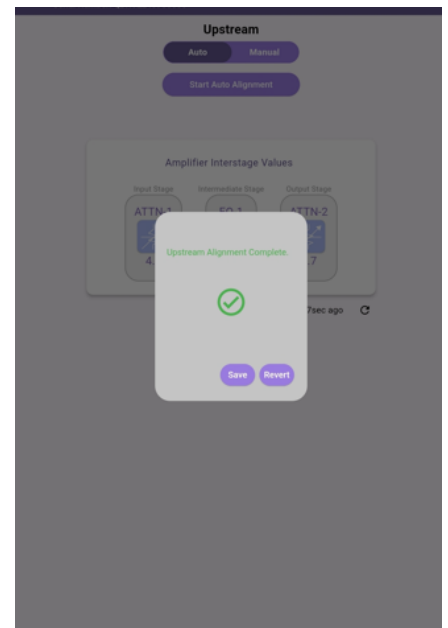

Figure 3- 24: Alignment Complete

UPSTREAM ALIGNMENT...continued

- For Manual Alignment-Select Manual: Figure 3-25. A Viavi “ONX-630” meter is required. The Viavi meter, in the DOCSIS Expert mode, will be used as the US alignment measurement tool. Initiate the US alignment procedure to force the US to adhere to the levels required for the desired network operation.

IMPORTANT: Failure to adjust the US levels properly could result in partial Node outages by driving the US levels to be either too high or too low.

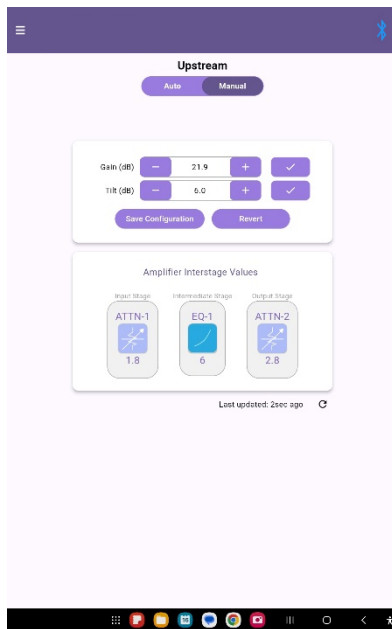

Figure 3- 25: Upstream Alignment

1. Select Manual
2. Adjust the Gain and Tilt one at a time to check the marker frequency levels.
3. The check box to the right of the +/- is pressed to apply the changes but are not saved.
4. After pressing the check box and selecting the Save Configuration all the changes are saved to the amp.
5. Should the results be undesirable, simply press the “Revert” key to return to factory pre-set which will allow US-Auto Align to override Manual activity.

Viavi DOCSIS Expert US-Settings		
F-Center	Type	RF Level
17.5	TDMA	38.0
24	TDMA	38.0
30.4	TDMA	38.0
36.8	TDMA	38.0

Table: Example of US settings for 750MHz

CASCADE ALSC ACTIVATION

Upon completion of both Downstream and Upstream Alignment, Enable ALSC for each amplifier:

- At main menu select Amplifier Config – Figure 3-26
- At Amplifier Config Select ALSC to the ON position – Figure 3-27
- Repeat for All Amplifiers in Cascade

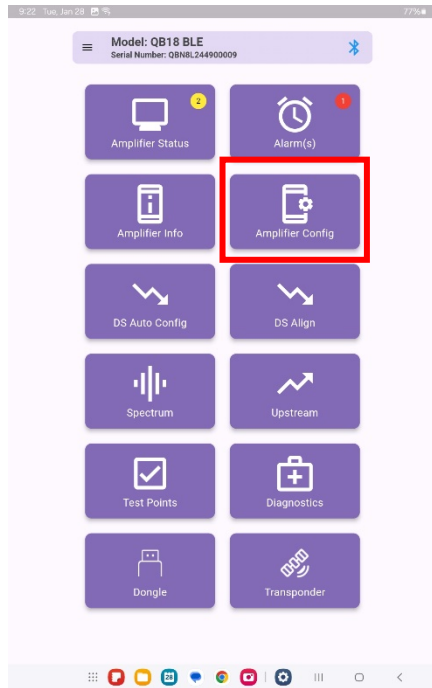

Figure 3- 26: Amplifier Config Tile

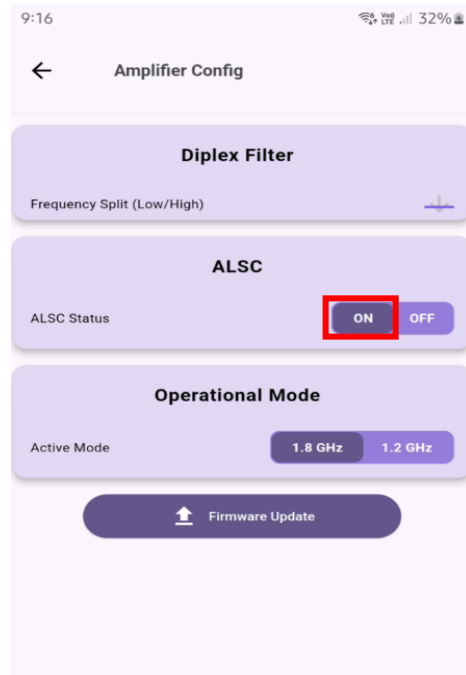

Figure 3- 27: ALSC Status

Installation and Operation Guide

TEST POINTS

Configuring Test Points for Measurement in the Downstream and the Upstream.

- At main menu select Test Points Tile – Figure 3-28.
- Select Test Point Operation – Figure 3-29.
 - FWDIN – Select either FWD IN or REV OUT to measure the desired upstream signal or downstream signal
 - FWDOUT – Select either FWD OUT or REV IN to measure the desired upstream signal or downstream signal

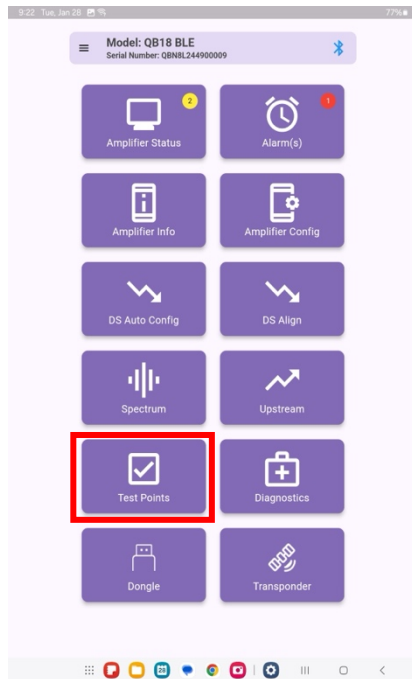

Figure 3- 28: Test Points

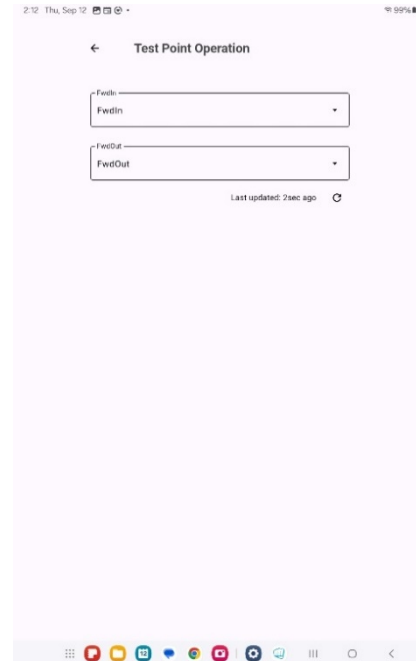

Figure 3- 29: Test Points

DIAGNOSTICS

To support troubleshooting Network reverse path ingress (noise) issues the reverse path “wink” switch can be used. This ingress “wink” switch is used to attenuate the US signals via three reverse path attenuation levels (0dB, 6dB, and 30dB).

- At main menu select Diagnostics Tile – Figure 3-30.
- In the Diagnostics Mode – Figure 31. The Ingress Switch can be selected to 3 Positions
 1. Off – 0 dB for normal operation
 2. 6 dB of attenuation is commonly used to isolate the coaxial spans before the US amplifier to isolate the ingress point(s) - SNR degradation
 3. Max ~ 30 dB of attenuation

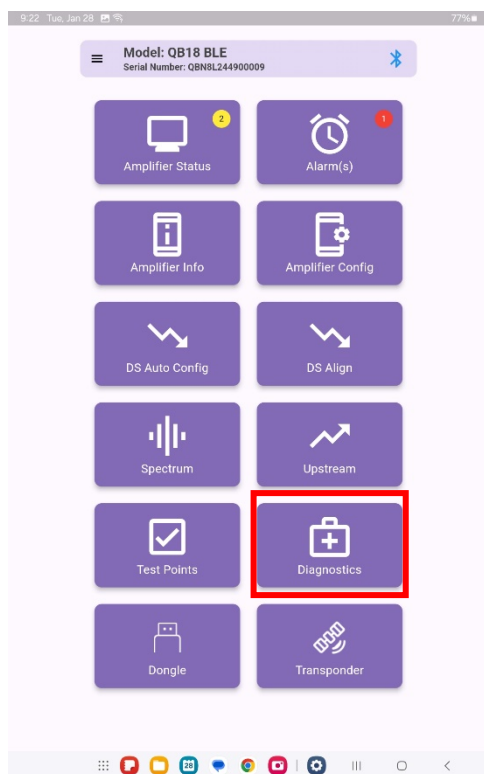

Figure 3- 30: Diagnostics Tile



Figure 3- 31: Diagnostics

4. TROUBLESHOOTING

In this Chapter...

INTRODUCTION 46

NO AC POWER 47

NO DC POWER 48

NO FORWARD RF SIGNAL 49

LOW OR DEGRADED FORWARD RF SIGNAL 50

NO REVERSE RF SIGNAL 51

LOW OR DEGRADED REVERSE RF SIGNAL 52

INTRODUCTION

The Quantum18 BLE 1.8GHz Line Extender is configured with modules that support different functions. This modular design approach provides the following benefits:

- The housing design has the flexibility to accept a variety of Diplex Filter modules.
- A Quantum Link transponder can be added to allow full amplifier control and telemetry

This chapter describes the steps you may take to troubleshoot the Quantum18 BLE 1.8GHz Line Extender.

NO AC POWER

AC power can be measured at the Quantum18 BLE 1.8GHz Line Extender seizure and AC test point next to the power harness on the Quantum18 BLE 1.8GHz Line Extender amplifier module.

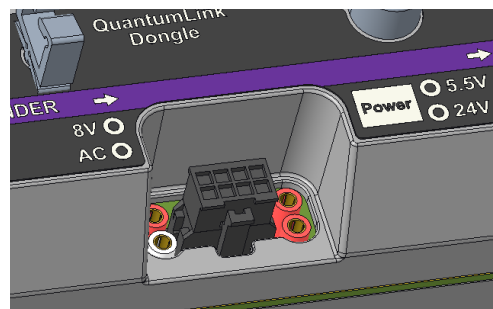

Figure 4- 1: AC Test Points

No AC Power Troubleshooting Table

Before you begin troubleshooting for no AC power, verify that there is proper AC power input coming into the Quantum18 BLE 1.8GHz Line Extender and that the AC voltage lockout threshold is set to your system's power requirements.

Possible Cause	Solution
No AC at the Housing Seizure	<ul style="list-style-type: none"> ■ Check the AC source. ■ Check the AC shunt power director configuration at the Amplifier feeding AC to this Amplifier. ■ Make sure that the housing seizure is properly tightened.
AC at the Housing Seizure But Not at the AC Test Point	<ul style="list-style-type: none"> ■ Verify that the amp module is fully seated in the housing base and the screws tightened as specified. ■ Check and / or replace the AC shunt power director. ■ Check and / or replace the Amplifier module.

NO DC POWER

DC power can be measured at the DC power supply test points and power wiring harness.

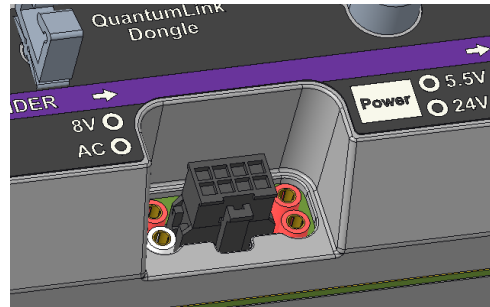

Figure 4- 2: DC Test Points

No DC Troubleshooting Table

Before you begin troubleshooting for no DC power, verify that there is proper AC power input coming into the DC power supply and that the AC voltage lockout threshold is set to your system's powering requirements.

Possible Cause	Solution
No DC Power at the amplifier DC test points	<ul style="list-style-type: none"> ■ Check and / or replace the power wiring harness ■ Check and / or replace the power supply.

NO FORWARD RF SIGNAL

The forward RF signal can be measured at the Quantum18 BLE 1.8GHz Line Extender amplifier module forward input and forward output test points.

No Forward RF Signal Troubleshooting Table

Before you begin troubleshooting for no forward RF signal, verify that the Quantum18 BLE 1.8GHz Line Extender amplifier module is receiving the proper forward RF input signal from the upstream equipment.

The forward and reverse signals share the same test points on the amplifier module. Use the QuantumLink Local Mobile app to set each test point to provide the desired signal. See Section 3. Test Points.

IMPORTANT: You cannot balance the line extender without the proper forward RF input signal.

Possible Cause	Solution
No Forward RF Signal at the Forward Input Test Point	<ul style="list-style-type: none"> ■ Verify that the amp module is fully seated in the housing base and the screws tightened as specified. ■ Verify the test point is configured to provide the forward input signal.
There Is Forward RF Signal at the Forward Input Test Point, But No Signal at One or All of the Forward Output Test Points	<ul style="list-style-type: none"> ■ Verify that the amp module is fully seated in the housing base and the screws tightened as specified. ■ Verify the test point is configured to provide the forward input signal. ■ Verify that the line extender module is receiving the proper AC and DC voltages. Refer to “No AC Power and No DC Power”. ■ Verify that all the plug-in accessories are firmly installed in the correct locations. ■ Verify the power LED is on and red and status LED is blinking green. NEED TO CONFIRM THIS BEHAVIOR. ■ Perform QuantumLink Local Downstream Auto-Alignment per Amplifier balancing, Section 3. ■ Replace the line extender amplifier module.

LOW OR DEGRADED FORWARD RF SIGNAL

The forward RF signal can be measured at the Quantum18 BLE 1.8GHz Line Extender amplifier module forward input and forward output test points.

Low or Degraded Forward RF Signal Troubleshooting Table

Before you begin troubleshooting for a low or degraded forward RF signal, verify that the Quantum18 BLE 1.8GHz Line Extender amplifier module is receiving the proper forward RF input signal from the upstream equipment.

The forward and reverse signals share the same test points on the amplifier module. Use the QuantumLink Local Mobile app to set each test point to provide the desired signal. See Section 3. Test Points.

IMPORTANT: You cannot balance the line extender without the proper forward RF input signal.

Make sure you have configured the line extender module according to the specifications in the design print, and that the line extender has warmed up for approximately one hour.

Possible Cause	Solution
Low or Degraded Reverse RF Signal at the Forward Input Test Point	<ul style="list-style-type: none"> Verify that the amp module is fully seated in the housing base and the screws tightened as specified.
There is a Proper Forward RF Signal at the Forward Input Test Point, But a Low or Degraded Signal at One or All of the Forward Output Test Points	<ul style="list-style-type: none"> Verify that the amp module is fully seated in the housing base and the screws tightened as specified. Verify that the line extender module is receiving the proper DC voltages. Refer to “No DC Power”. Verify that all the plug-in accessories are firmly installed in the correct locations. Verify the power LED is on and red and status LED is blinking green. NEED TO CONFIRM THIS BEHAVIOR. Perform the Downstream alignment process via the QuantumLink Local application. Refer to “Balancing and Setup”, Section 3 for more information. Replace the line extender amplifier module .

NO REVERSE RF SIGNAL

The reverse RF signal can be measured at the Quantum18 BLE 1.8GHz Line Extender amplifier module reverse input and reverse output test points.

No Reverse RF Signal Troubleshooting Table

Before you begin troubleshooting for no reverse RF signal, verify that the Quantum18 BLE 1.8GHz Line Extender amplifier module is receiving the proper reverse RF input signals from the downstream line extender at the line extender reverse input test point.

The forward and reverse signals share the same test points on the amplifier module. Use the QuantumLink Local Mobile app to set each test point to provide the desired signal. See section 3. Test Points.

IMPORTANT: You cannot balance the line extender without the proper reverse RF input signals.

Possible Cause	Solution
No Reverse RF Signal at the Reverse Input Test Point	<ul style="list-style-type: none"> ■ Verify that the amp module is fully seated in the housing base and the screws tightened as specified. ■ Verify the test point is configured to provide the reverse input signal.
There is a Proper Reverse RF Signal at the Reverse Input Test Point, But No Signal at the Reverse Output Test Point	<ul style="list-style-type: none"> ■ Verify that the amp module is fully seated in the housing base and the screws tightened as specified. ■ Verify the test point is configured to provide the reverse input signal. ■ Verify that the line extender module is receiving the proper AC and DC voltages. Refer to “No AC Power” and “No DC Power”. ■ Verify that the line extender module is receiving the proper forward RF signal. Refer to “No Forward RF Signal”. ■ Verify that all the plug-in accessories are firmly installed in the correct locations. ■ Verify the power LED is on and red and status LED is blinking green. NEED TO CONFIRM THIS BEHAVIOR. ■ Replace the line extender amplifier module.

LOW OR DEGRADED REVERSE RF SIGNAL

The reverse RF signal can be measured at the Quantum18 BLE 1.8GHz Line Extender amplifier module reverse input and reverse output test points.

Low or Degraded Reverse RF Signal Troubleshooting Table

Before you begin troubleshooting for a low or degraded reverse RF signal, verify that the Quantum18 BLE 1.8GHz Line Extender amplifier module is receiving the proper reverse RF input signals from the downstream line extender at the line extender reverse input test point.

The forward and reverse signals share the same test points on the amplifier module. Use the QuantumLink Local Mobile app to set each test point to provide the desired signal. See section 3 Test Points.

IMPORTANT: You cannot balance the line extender without the proper reverse RF input signals.

Make sure you have configured the line extender amplifier module according to the specifications in the design print, and that the line extender has warmed up for approximately one hour.

Make sure you are using the proper total tilt reference when setting receive levels. Refer to the reverse equalizer charts in “**Technical Information**” for more information.

IMPORTANT: If the line extender cover was ever removed, make sure it was properly reinstalled. Improperly reinstalling the line extender module cover may result in RF signal degradation.

Possible Cause	Solution
Low or Degraded Reverse RF Signal at the Reverse Input Test Point	<ul style="list-style-type: none"> Verify that the amp module is fully seated in the housing base and the screws tightened as specified.
There are Proper Reverse RF Signals at the Reverse Input Test Point, But a Low or Degraded Signal at the Reverse Output Test Point	<ul style="list-style-type: none"> Verify that the amp module is fully seated in the housing base and the screws tightened as specified. Verify that the line extender module is receiving the proper DC voltages. Refer to “No DC Power”. Measure the main reverse input test point and the reverse output test point. Subtract the reverse amplifier gain and add the pad values and EQ insertion loss to verify proper reverse amplifier gain. Verify that all the plug-in accessories are firmly installed in the correct locations. Verify the power LED is on and red and status LED is blinking green. NEED TO CONFIRM THIS BEHAVIOR. Perform the Upstream alignment process via the QuantumLink Local application. Refer to “Balancing and Setup”, Section 3 for more information.

Installation and Operation Guide

Possible Cause	Solution
Reverse RF Signal Still Low or Degraded	<ul style="list-style-type: none">■ Use a spectrum analyzer to look at the reverse RF input signal spectral quality at each reverse input test point and compare it to the reverse RF output signal spectral quality.<ul style="list-style-type: none">— If degradation is generated in the reverse amplifier, replace the line extender module.— If degradation is generated by the downstream line extender reverse RF signal, troubleshoot the line extender feeding this station.■ Replace the line extender amplifier module.

5. CUSTOMER SUPPORT INFORMATION

IF YOU HAVE QUESTIONS

If you have technical questions, call AOI for assistance. Follow the menu options to speak with a service engineer.

Access your company's extranet site to view or order additional technical publications. For accessing instructions, contact the representative who handles your account. Check your extranet site often as the information is updated frequently.

RF SPLIT UPGRADE APPLICATION NOTE

APPENDIX A: RF SPLIT UPGRADE APPLICATION NOTE

In this Application Note...

BEFORE YOU BEGIN 2

UPGRADING THE RF SPLIT IN THE QUANTUM 18 BLE 1.8GHZ LINE EXTENDER 4

CONNECT TO QUANTUMLINK LOCAL FOR CONFIGURATION AND VERIFICATION 9

TO CLOSE THE HOUSING 15

Glossary

BEFORE YOU BEGIN**Introduction**

As cable operators face an exponential rise in the requirements for more reverse path bandwidth driven by the popularity of advanced, on-demand services from an increasing number of subscribers, operators need an upgrade path for deployed equipment to overcome this operational challenge. Commercial services driven by mixed-use urban environments is a practical example of geographic portions of the outside plant where the service provider may wish for more symmetric data services.

Purpose

This application note describes the RF split upgrade procedure for Quantum18 BLE 1.8GHz Line Extender.

You will note that the final instruction in the split change process calls for the verification the split change was successful using the QuantumLink Local Mobile Application. This verification is included to ensure that all component replacements with respect to the split upgrade were performed correctly and to ensure that all replacement components perform as specified.

Should you need assistance with your upgrade, contact Applied Optoelectronics Inc. for support.

**WARNING:**

Avoid electric shock. Opening or removing this equipment cover may expose you to dangerous voltages. RF split upgrades should only be conducted on amplifiers that have been removed from the cable system, not on amplifiers actively in service.

Qualified Personnel**CAUTION:**

Allow only qualified and skilled personnel to install, operate, maintain, and service this product. Otherwise, personal injury, or equipment damage may occur.

Related Publications

You may find the following publications useful as you implement the procedures in this document.

- *Quantum18 BLE 1.8GHz Line Extender Installation and Operation Guide*

Glossary

Components Required to Make the Split Change

- (1) High Pass Filter Trim Assembly
- (1) Low Pass Filter Trim Assembly
- (1) Mirrored Diplex Filters
- (1) Non-mirrored Diplex Filters
- Part number label

NOTE: *Part numbers differ depending on desired final split.*

Equipment Required to Make the Split Change

- 1/2" and 7/16" wrench or nut driver.
- Torque wrench with a 7/16" socket
- Phillips-head screw driver
- T-10 Torx-bit screwdriver

Glossary

UPGRADING THE RF SPLIT IN THE QUANTUM 18 BLE 1.8GHZ LINE EXTENDER

There are two methods associated with upgrading the RF split of an amplifier in the field. The first method is upgrading the RF Split on the Amplifier Module by swapping the accessories to the new frequency split without powering down the amplifier. The second method is to swap the existing Amplifier module with a new amplifier module that has the new split. Swapping the Amplifier modules in the field requires removing power from the original Amplifier module before removal and powering the new Amplifier module after installation. Removing the **Red** shunt, removes power from the Amplifier module. After installing the replacement Amplifier module, power is restored by installing the **Red** shunt in the same location as previously used. The Black shunt, if used, will allow power to be fed down/up the line.

NOTE: For Amplifier module installation, after module is installed, install the Black Shunt first and then install the Red Shunt.

The follow the steps outline upgrading the RF Split for the 1.8GHz Amplifier Module, presently installed in the field, by swapping the accessories to the new frequency split.

IMPORTANT: Before unscrewing the housing bolts, if the housing uses a locking screw, make sure the removable locking screw in the hinge is in place and secure. The locking screw prevents separation of the lid from the base.

Upgrading the Amplifier Module

1. Unscrew the 7/16" housing closure bolts on the housing lid until they are loose.

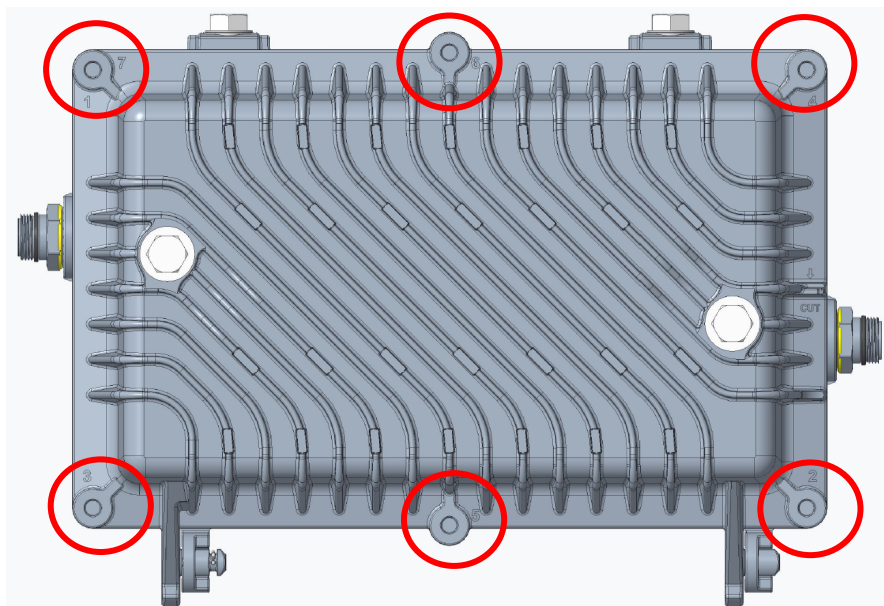

Figure A- 1: Closure Bolts

Glossary

2. Open the housing.

NOTE: The closure bolts will remain attached to the housing.

3. Remove the AC shunt power directors from the amplifier before you remove the amplifier module from the housing. A red shunt indicates the input power port.
4. Unplug the 8-pin keyed connector of the power cable harness from the line extender amplifier module.
5. Remove the power cable harness from the white plastic retainer clip.
6. Remove the two (2) Diplex filters and the (1) High Pass Filter Trim.
7. Install the two (2) new Diplex filters and the new (1) High Pass Filter Trim.

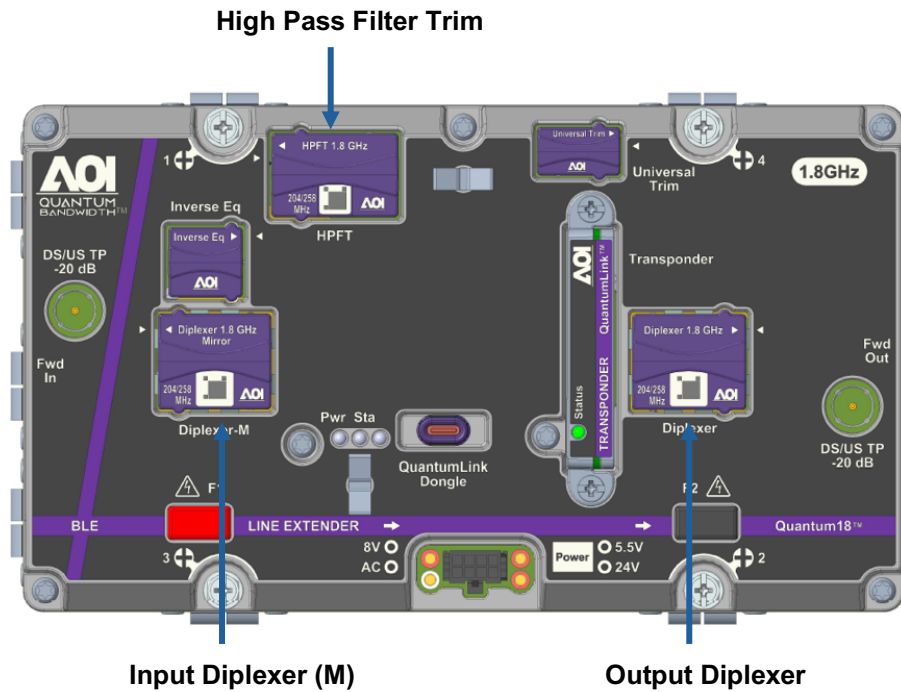

Figure A- 2: Filter and Diplex Locations

Glossary

- To replace the (1) Low Pass Filter Trim, the Quantum18 BLE 1.8GHz Line Extender amplifier module must be removed by loosening the four module retaining screws

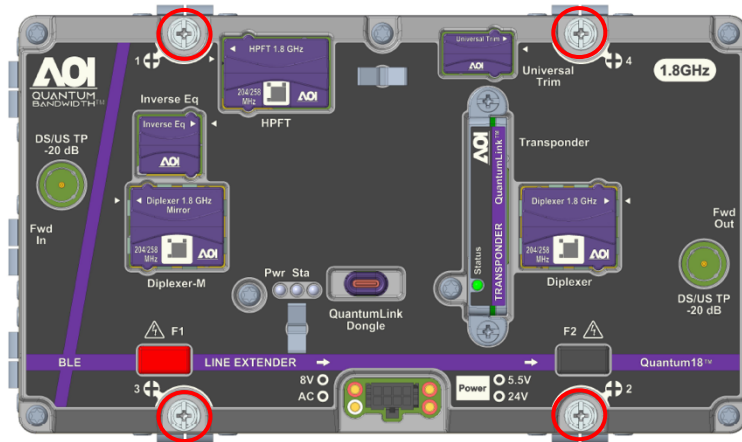

Figure A- 3: Retainer Screws

- Remove the Quantum18 BLE 1.8GHz Line Extender amplifier module and turn upside down to show the bottom. Remove eleven (11) T-10 Torx screws, set cover aside and be careful not to lose screws.

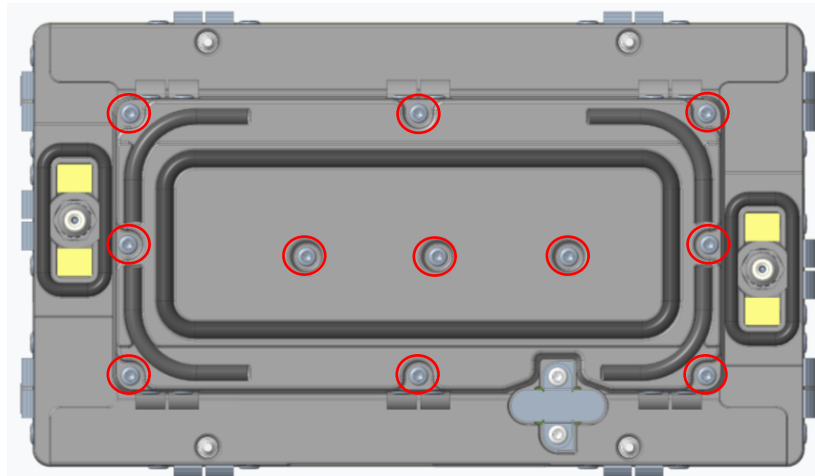

Figure A- 4: Bottom Cover Torx Screws

NOTE: Development to create an opening to Access Low Pass Filter Trim through the Bottom Cover is in process

Glossary

10. Remove the Low Pass Filter Trim and replace with the new Low Pass Filter Trim.

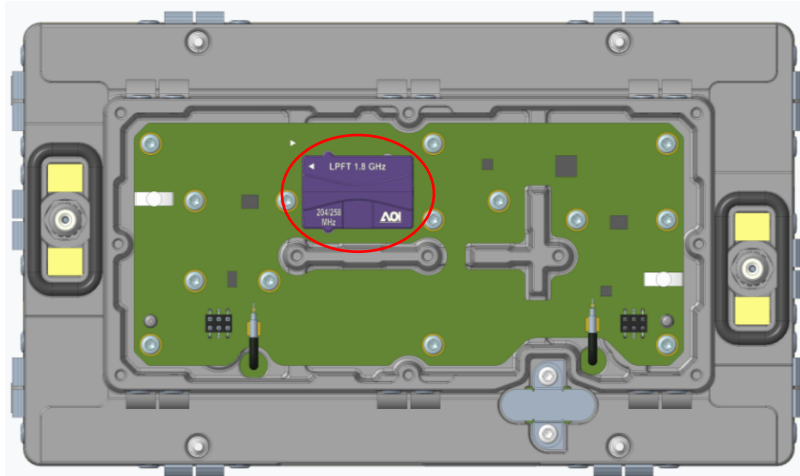

Figure A- 5: Low Pass Filter Trim

11. Install eleven (11) T-10 Torx screws, set cover aside and re-install Quantum18 BLE 1.8GHz Line Extender amplifier module. Tighten bottom cover Torx screws to 10.8 in-lb to 12.2 in-lb (1.2 Nm to 1.4 Nm).

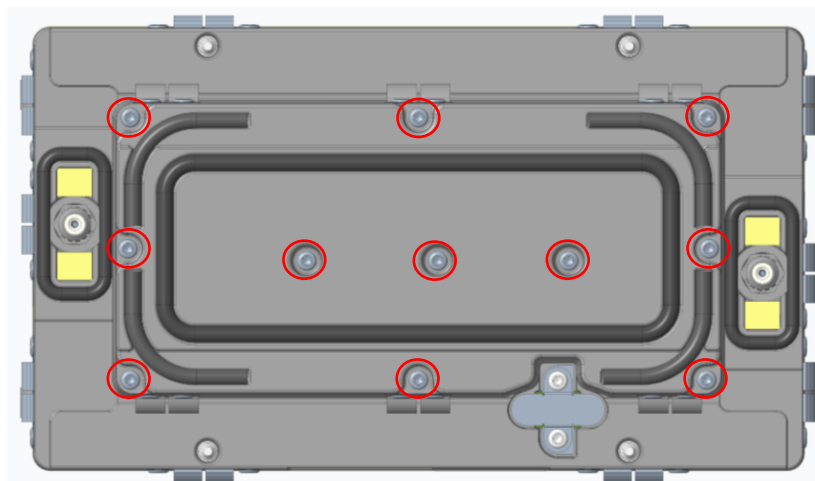

Figure A- 6: Bottom Cover Torx Screws

Glossary

1. Line up the RF connectors on the Quantum18 BLE 1.8GHz Line Extender amplifier module and the housing, and then push the Quantum18 BLE 1.8GHz Line Extender amplifier module into the housing.
2. Secure the Quantum18 BLE 1.8GHz Line Extender amplifier module to the housing by tightening the four in-line extender module retainer screws. Tighten combo head screws to 18 in-lb to 20 in-lb (2.0 Nm to 2.25 Nm). See the following illustration for the location of the retainer screws

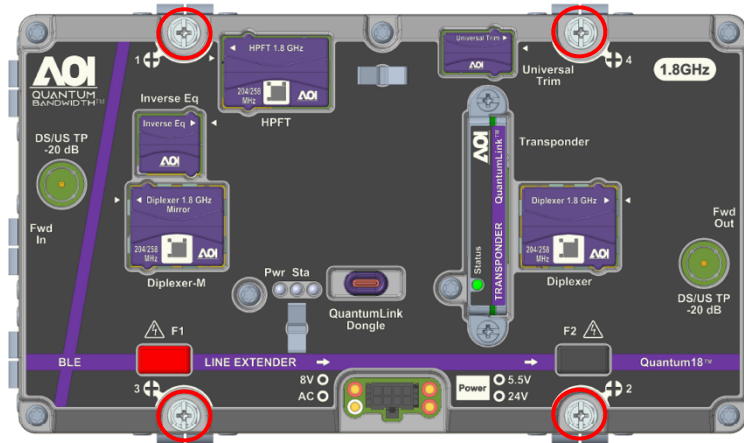

Figure A- 7: Retainer Screws

3. Snap the power cable harness into place in the holes provided.
4. Attach the 8-pin keyed connector of the power cable and harness to the line extender amplifier module.

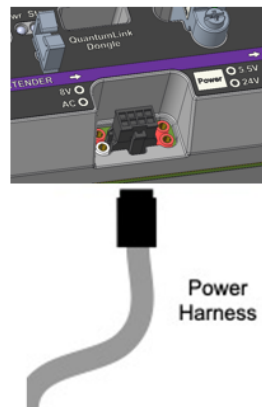

Figure A- 8: Power Harness

Glossary

2. Preparing for RF Split Upgrade

- Locate and Initiate QuantumLink Local Mobile Application on the Technician's portable device (Tablet/Handheld), see Figure A-10.
- Insert the QuantumLink Local Wireless Interface in the Quantum18 BLE 1.8GHz Line Extender amplifier module as shown above. Figure A-9.
- Establish point to point connections via Bluetooth between the technician's portable device and the QuantumLink Local Wireless Interface by using "Select Device" drop down in the QuantumLink Local Mobile Application menu to select the proper QuantumLink Local Wireless Interface. Figure A-11.
- Log into the QuantumLink Local Mobile Application, using an accepted username and password. Figure A-12.

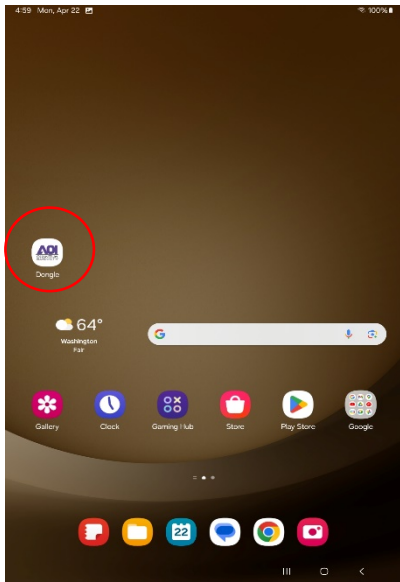

Figure A- 10: Home Screen

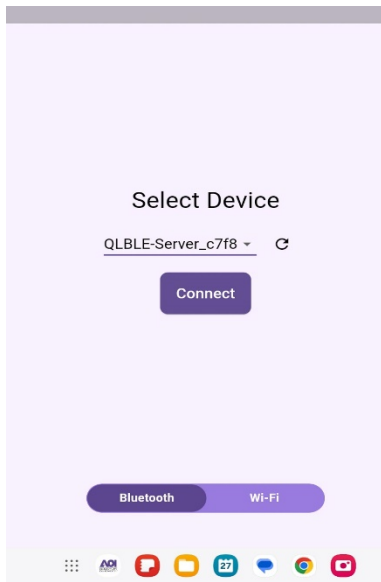

Figure A- 11: Device Connection

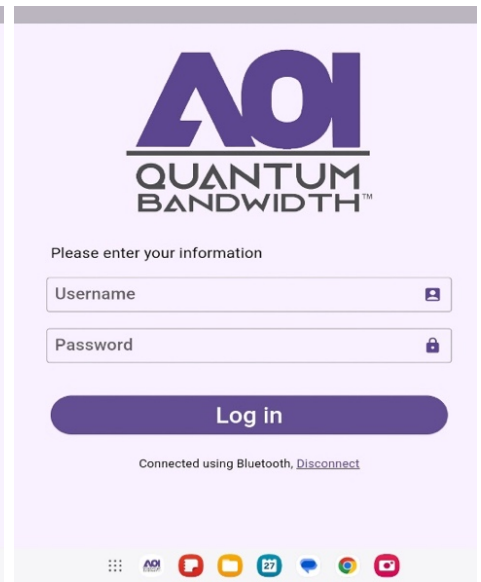

Figure A- 12: Login

Glossary

3. From the Home screen, select the Amplifier Config Tile Figure A-13.
4. Diplex Filter – Select the new split from the frequency split drop down menu, see Figure A-14.
5. Save changes and return to the Home screen.

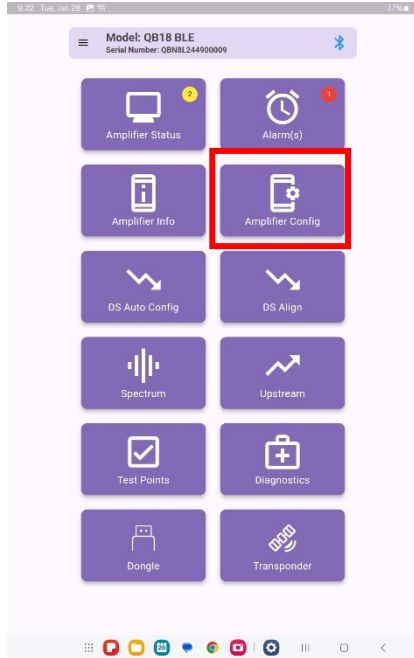

Figure A- 13: Amplifier Config Tile

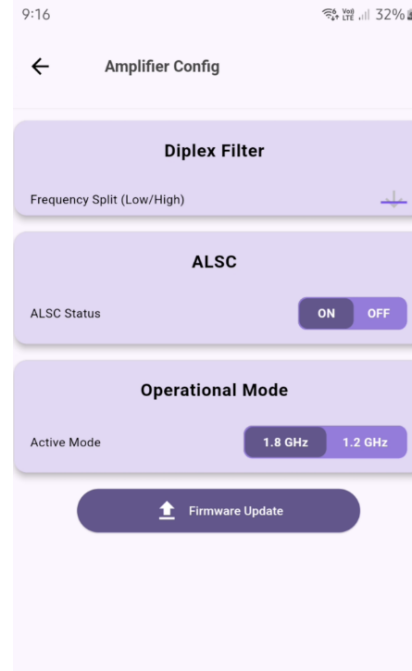

Figure A- 14: Diplex Filter Settings

Glossary

6. Select the DS Auto Config Tile. Figure A-15.
7. Confirm the Downstream Config Parameters for: Auto Config, ALSC and Auto Align Marker Pilots correctly matches the site profile data loaded. Once confirmed select "Apply" and return to the Home screen, see Figure A-16.

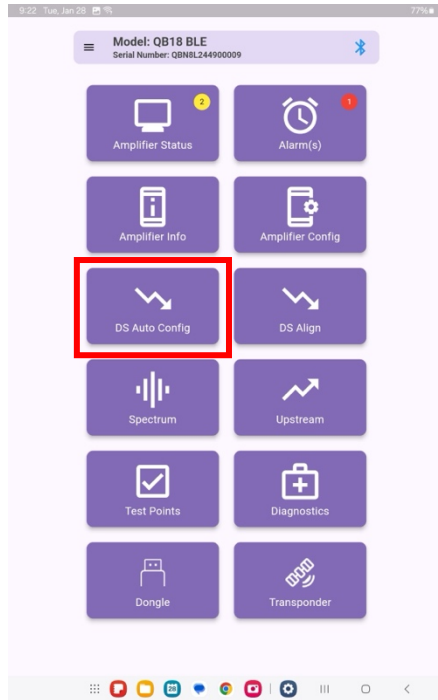

Figure A- 15: DS Auto Config Tile

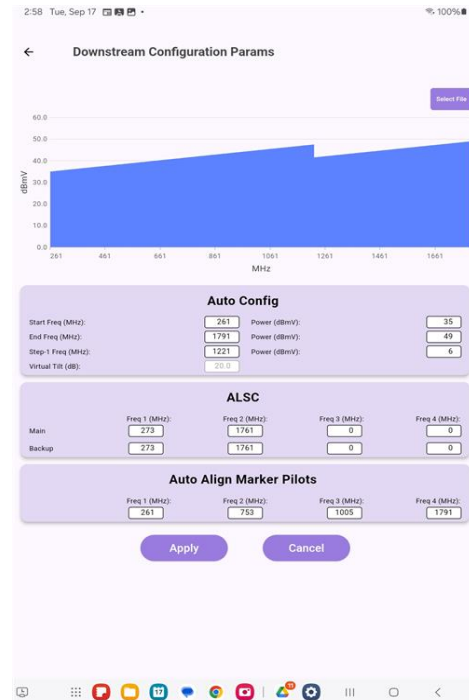

Figure A- 16: Configuration Settings

Glossary

8. Select the DS Align Tile Figure A-17.
9. Verify pilot carriers (frequency) are correctly stored in the amplifier. Once confirmed, return to the Home screen.

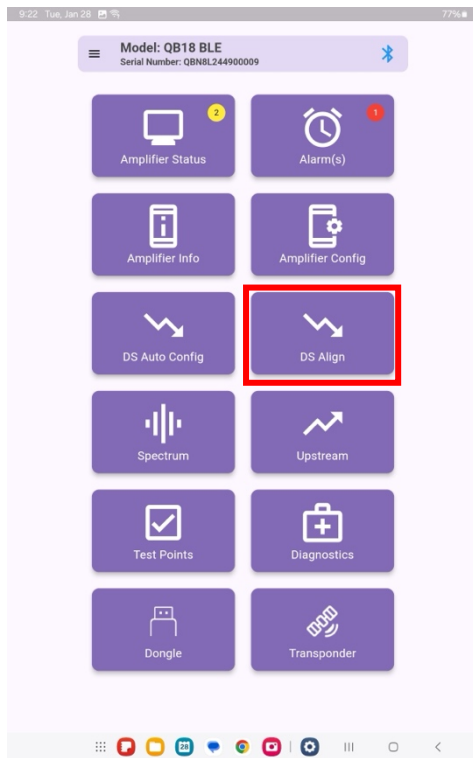

Figure A- 17: DS Align Tile

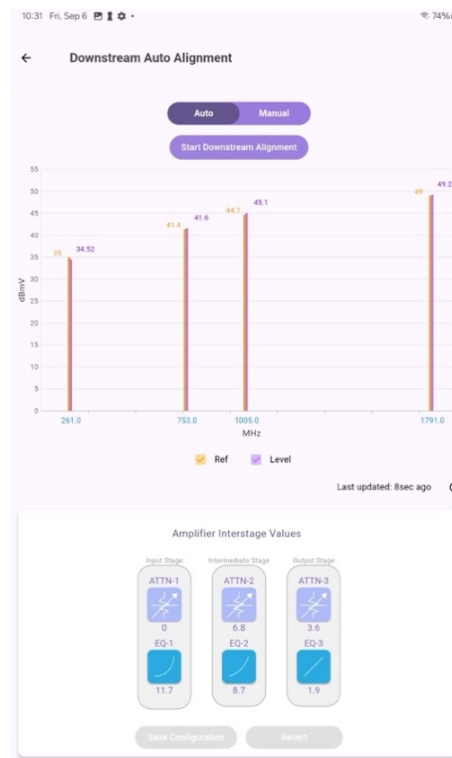

Figure A- 18: Alignment Settings

NOTE: This Quantum18 BLE 1.8GHz Line Extender is designed to be auto-aligning and requires no in-field adjustments to its RF levels.

Glossary

10. Select Spectrum Tile Figure A-19.
11. Execute a Spectrum Capture "spectrum capture. Verify that the spectrum displayed begins at the appropriate frequency and that the measured signal level closely correlates with the target level.

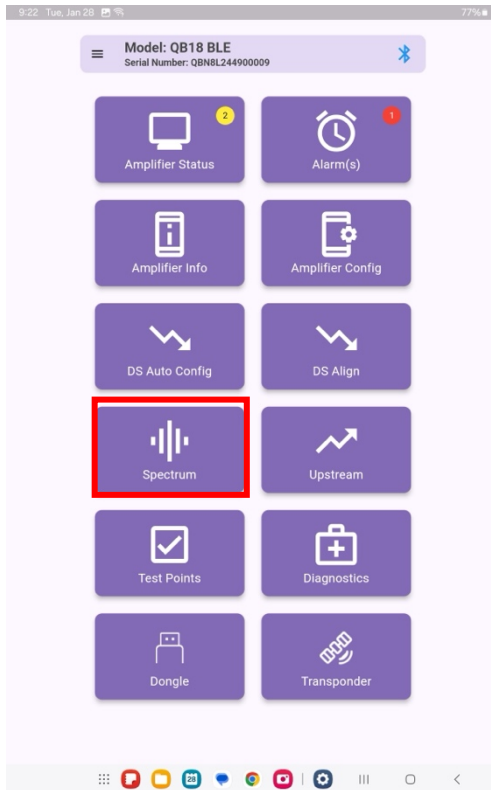

Figure A- 19: Spectrum Tile



Figure A- 20: Spectrum Capture

12. Final Step – Remove the QuantumLink Local Wireless Interface, before closing lid.

Glossary

TO CLOSE THE HOUSING

1. Close the housing and finger-tighten all closure bolts.
2. Use a torque wrench with a 7/16" socket to tighten each closure bolt from 5 ft-lb to 12 ft-lb (6.8 Nm to 16.3 Nm) each.
3. Follow the numbered tightening sequence to tighten the closure bolts.

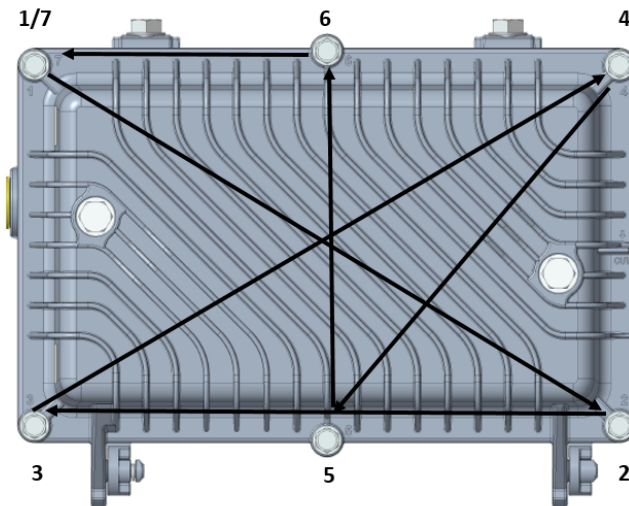

Figure A- 21: Torqueing Sequence

GLOSSARY

A	Ampere A unit of measure for electrical current.
ac / AC	Alternating Current An electric current that reverses its direction at regularly recurring intervals.
ALSC	Automatic Slope & Level Control A process or means by which gain is automatically adjusted in a specified manner as a function of input level or other specified parameters.
CW	Continuous Wave
dB	Decibel One tenth of a bel, the number of decibels denoting the ratio of two amounts of power being ten times the common logarithm of this ratio.
dBc	Decibels relative to a reference carrier.
dBm	Decibels relative to one milliwatt.
dBmV	Decibels relative to one millivolt.
dBW	Decibels relative to one watt.
dc / DC	Direct Current An electric current flowing in one direction only and substantially constant in value.
DS	Down Stream – Reverse Path
DUT	Device Under Test
EMC	Electromagnetic Compatibility A measure of equipment tolerance to external electromagnetic fields.
EQ	Equalizer
Equalization	The process of compensating for an undesired result. For example, equalizing tilt in a distribution system.

Glossary

FCC	Federal Communications Commission Federal organization set up by the Communications Act of 1934 which has authority to regulate all inter-state (but not intra-state) communications originating in the United States (radio, television, wire, satellite, and cable).
FEV	Front Equipment View
ft-lb	Foot-Pound A measure of torque defined by the application of one pound of force on a lever at a point on the lever that is one foot from the pivot point.
Gain	A measure of the increase in signal level, relative to a reference, in an amplifier. Usually expressed in decibels.
GHz	Gigahertz A unit of frequency equal to one billion cycles per second.
Hertz	A unit of frequency equal to one cycle per second.
I/O	Input / Output
in-lb	Inch-Pound A measure of torque defined by the application of one pound of force on a lever at a point on the lever that is one inch from the pivot point.
LE	Line Extender
LED	Light-Emitting Diode An electronic device that lights up when electricity passes through it.
Mbps	Megabits Per Second A unit of measure representing a rate of one million bits (megabits) per second.
MHz	Megahertz A unit of measure representing one million cycles per second; measures bandwidth.
N-cm	Newton Centimeter

Glossary

Nm	<p>Newton Meter</p> <p>A measure of torque defined by the application of one Newton of force on a lever at a point on the lever that is one meter from the pivot point (1 Nm = 0.737561 ft-lb).</p>
PCB/PWB	Printed Circuit Board/Printed Wiring Board
RF	<p>Radio Frequency</p> <p>The frequency in the portion of the electromagnetic spectrum that is above the audio frequencies and below the infrared frequencies, used in radio transmission systems.</p>
RMA	<p>Return Material Authorization</p> <p>A form used to return products.</p>
RX	Receive or Receiver
S/N or SNR	<p>Signal-to-Noise Ratio</p> <p>The ratio, in decibels, of the maximum peak-to-peak voltage of the video signal, including synchronizing pulse, to the root-mean-square voltage of the noise. Provides a measure and indication of signal quality.</p>
SA	System Amplifier
Torque	A force that produces rotation or torsion. Usually expressed in lb-ft (pound-feet) or N-m (Newton-meters). The application of one pound of force on a lever at a point on the lever that is one foot from the pivot point would produce 1 lb-ft of torque.
TX	Transmit or Transmitter
US	Up Stream – Forward Path
V	Volt
V AC	Volts Alternating Current
V DC	Volts Direct Current
W	<p>Watt</p> <p>A measure of electrical power required to do work at the rate of one joule per second. In a purely resistive load, 1 Watt = 1 Volt x 1 Amp.</p>



World Headquarters Applied
Optoelectronics, Inc. 13139 Jess
Pirtle Boulevard Sugar Land, TX
77478

AOI and the AOI logo are trademarks or registered trademarks of AOI and / or its affiliates in the U.S. and other countries. To view a list of AOI trademarks, go to this URL:

<http://www.ao-inc.com>