

SFP Dual LC 4.25G (Multi Rate) MMF 150m 850nm Transceiver

A5WLSN85ADMA0541



Features

- ❑ SFP Type Dual LC Transceiver
- ❑ 850nm VCSEL Laser
- ❑ PIN Photo Detector
- ❑ 150m transmission with 50/125um MMF
- ❑ 70m transmission with 62.5/125um MMF
- ❑ 3.3V single power supply
- ❑ Compliant with SFP MSA
- ❑ Compliant with FC-PI-2
- ❑ Hot pluggable
- ❑ Serial ID information support
- ❑ Digital diagnostic SFF-8472 compliant
- ❑ Compliant with RoHS
- ❑ Compliant with UL & TUV

Applications

- ❑ Fiber Channel 4xFC (4.25Gbps)
- ❑ Fiber Channel 2xFC (2.125Gbps)
- ❑ Fiber Channel 1xFC (1.0625Gbps)
- ❑ Gigabit Ethernet (1.25Gbps)

Ordering Information

Form Factor	Date Rate	Media	Distance	Wavelength (nm)	TX Power (dBm)	RX Sensitivity (dBm)	Voltage (V)	Coupling	Signal Detect	DDM (Y/N)	Temperature (°C)	Part Number
SFP-Dual-LC	4.25G	MMF	150m	850	-2.5 ~ -9	< -15	3.3	AC/AC	TTL	Y	-5 ~ +70	A5WLSN85ADMA0541



SFP Dual LC 4.25G (Multi Rate) MMF 150m 850nm Transceiver

A5WLSN85ADMA0541

Absolute Maximum Ratings

Parameter	Symbol	Conditions	Min	Max	Unit
Storage Temperature	T _S	--	-40	+85	°C
Storage Relative Humidity	RH	--	5	95	%
Supply Voltage	V _{CC}	--	0	4.0	V

Recommended Operating Conditions

Parameter	Symbol	Conditions	Min	Typ	Max	Unit
Operating Temperature (Case)	T _C	A5WL-SN85-ADMA	-5	--	70	°C
Supply Voltage	V _{CC}	--	3.13	3.3	3.47	V
Supply Current	I _{TX} + I _{RX}	--	--	--	300	mA
Data Rate	DR	--	--	4.25	--	Gbps

Electrical Characteristics

Parameter	Symbol	Conditions	Min	Typ	Max	Unit
Transmitter						
Differential Input Impedance	R _{DI}	--	--	100	--	Ohm
Differential Input Voltage	V _{DI}	AC-Coupled, peak to peak	0.50	--	2.40	V
Tx Disable Input-High	V _{DISH}		2.0	--	V _{CC} +0.3	V
Tx Disable Input-Low	V _{DISL}		0	--	0.8	V
Tx Fault Output-High	V _{FOH}		2.0	--	V _{CC} +0.3	V
Tx Fault Output-Low	V _{FOL}		0	--	0.8	V
Receiver						
Differential Output Impedance	R _{DO}	--	--	100	--	Ohm
Differential Output Voltage	V _{DO}	AC-Coupled, peak to peak	0.37	--	2.00	V
Rx LOS Output-High	V _{LOSH}		2.00	--	V _{CC} +0.3	V
Rx LOS Output-Low	V _{LOSL}		0.00	--	0.80	V

Optical Characteristics

Parameter	Symbol	Conditions	Min	Typ	Max	Unit
Transmitter						
Optical Center Wavelength	λ _c	--	830	850	860	nm
Spectral Width	Δλ	(RMS)	--	--	0.85	nm
Optical Output Power	P _O	Coupling into a 62.5/125um MMF	-9	--	-2.5	dBm
Optical Modulation Amplitude	OMA	@4.25Gb/s	247	--	--	uW
Optical Rise/Fall Time	t _r / t _f	20 % to 80% Values @4.25Gb/s	--	--	90	ps
Eye Mask	--	Compliant with FC-PI-2				
Receiver						
Operating Wavelength	λ	--	770	850	860	nm
Receiver Overload	P _{IN} MAX	1	0	--	--	dBm
Receiver Sensitivity@4.25Gbps	P _{IN} MIN	1	--	--	-15	dBm
Receiver Sensitivity@2.125Gbps	P _{IN} MIN	1	--	--	-17	dBm
Receiver Sensitivity@1.25Gbps	P _{IN} MIN	1	--	--	-17	dBm
Receiver Sensitivity@1.0625Gbps	P _{IN} MIN	1	--	--	-17	dBm
Rx LOS Assert	P _A	--	-30	--	--	dBm
Rx LOS De-Assert	P _D	--	--	--	-17	dBm
Rx LOS Hysteresis	P _A -P _D	--	0.5	--	--	dB

1. Measured with PRBS 2⁷ -1 at 10⁻¹² BER

Recommended Host Board Power Supply

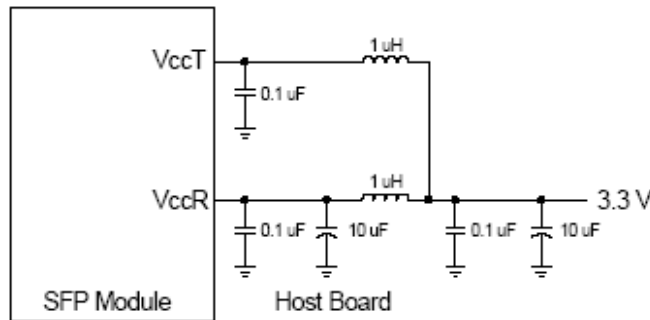

Recommended Interface Circuit

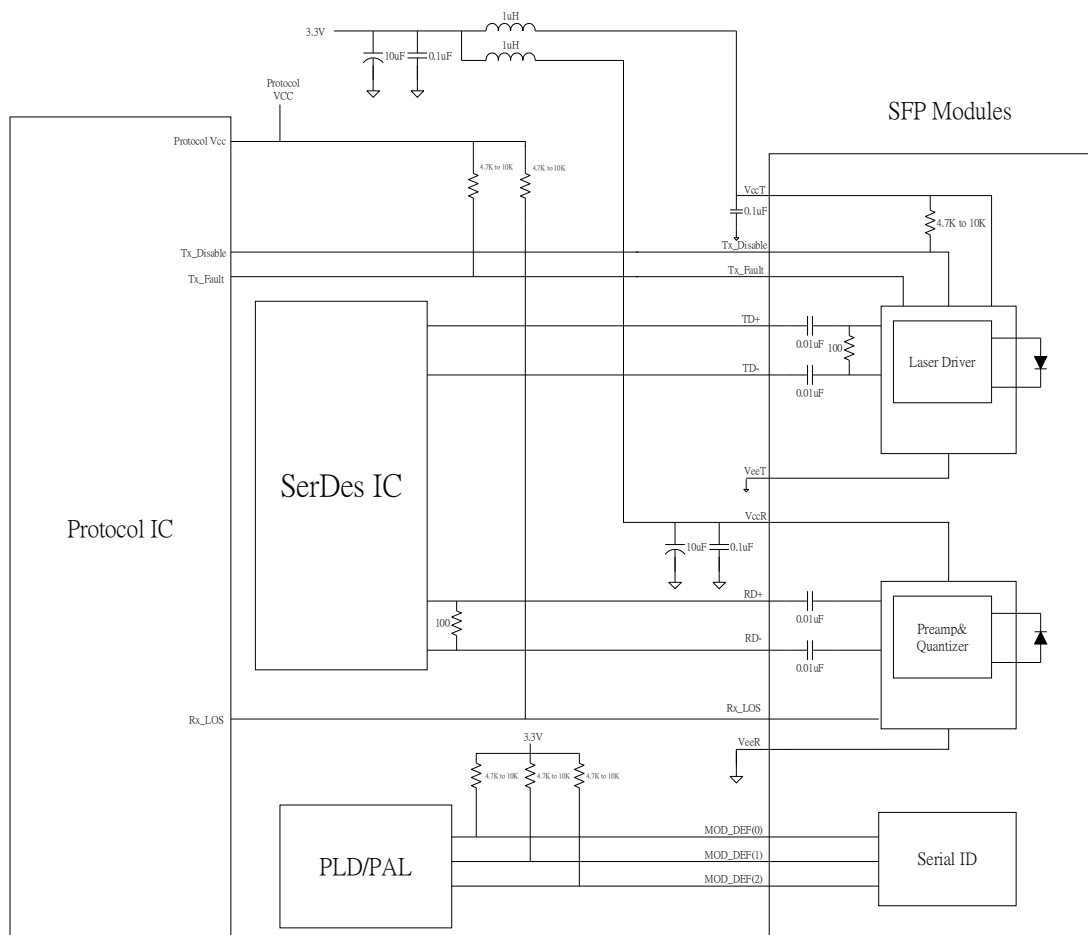

Pin Description

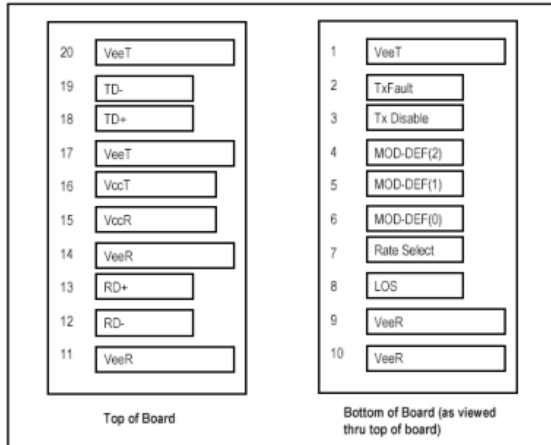

SFP Transceiver Electric Pad Layout

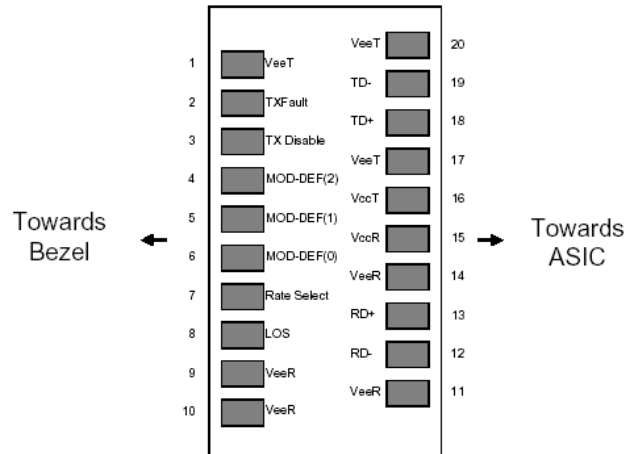

Diagram of Host Board Connector Block Pin Numbers and Names

Pin Function Definitions

Pin No.	Pin Name	Function	Plug Seq.	Note
1	VeeT	Transmitter Ground	1	
2	TX Fault	Transmitter Fault Indication	3	1
3	TX Disable	Transmitter Disable	3	2
4	MOD_DEF 2	Module Definition 2	3	3
5	MOD_DEF 1	Module Definition 1	3	3
6	MOD_DEF 0	Module Definition 0	3	3
7	Rate Select	No connection	3	4
8	LOS	Loss of Signal	3	5
9	VeeR	Receiver Ground	1	6
10	VeeR	Receiver Ground	1	6
11	VeeR	Receiver Ground	1	6
12	RD -	Inv. Receiver Data Out	3	7
13	RD +	Receiver Data Out	3	7
14	VeeR	Receiver Ground	1	6
15	VccR	Receiver Power	2	8
16	VccT	Transmitter Power	2	8
17	VeeT	Transmitter Ground	1	6
18	TD +	Transmitter Data In	3	9
19	TD -	Inv. Transmitter Data In	3	9
20	VeeT	Transmitter Ground	1	6

**Notes:**

Plug Seq.: Pin engagement sequence during hot plugging.

1. TX Fault is an open collector/drain output, which should be pulled up with a 4.7K – 10K Ω resistor on the host board. Pull up voltage between 2.0V and VccT, R+0.3V. When high, output indicates a laser fault of some kind. Low indicates normal operation. In the low state, the output will be pulled to < 0.8V.
2. TX disable is an input that is used to shut down the transmitter optical output. It is pulled up within the module with a 4.7 – 10 K Ω resistor. Its states are:
 - Low (below 0.8V): Transmitter on
 - (>0.8, < 2.0V): Undefined
 - High (above 2.0v): Transmitter Disabled
 - Open: Transmitter Disabled
3. Mod-Def 0,1,2. These are the module definition pins. They should be pulled up with a 4.7K - 10K Ω resistor on the host board. The pull-up voltage shall be VccT or VccR
 - Mod-Def 0 is grounded by the module to indicate that the module is present
 - Mod-Def 1 is the clock line of two wire serial interface for serial ID
 - Mod-Def 2 is the data line of two wire serial interface for serial ID
4. This is an optional input used to control the receiver bandwidth for compatibility with multiple data rates (most likely Fiber Channel 1x and 2x Rates). If implemented, the input will be internally pulled down with > 30k Ω resistor. The input states are:
 - Low (below 0.8V): Reduced Bandwidth
 - (>0.8 , < 2.0V): Undefined
 - High (above 2.0 V): Full Bandwidth
 - Open: Reduced Bandwidth
5. LOS (Loss of Signal) is an open collector/drain output, which should be pulled up with a 4.7K -10K Ω resistor on the host board. Pull up voltage between 2.0V and VccT, R+0.3V. When high, this output indicates the received optical power is below the worst-case receiver sensitivity (as defined by the standard in use). Low indicates normal operation. In the low state, the output will be pulled to < 0.8V.
6. VeeR and VeeT may be internally connected within the SFP module.
7. RD-/+: These are the differential receiver outputs. They are AC coupled 100 Ω differential lines which should be terminated with 100 Ω (differential) at the user SERDES. The AC coupling is done inside the module and is thus not required on the host board.
8. VccR and VccT are the receiver and transmitter power supplies. Maximum supply current is 300 mA. Recommended host board power supply filtering is shown below. Inductors with DC resistance of less than 1 Ω should be used in order to maintain the required voltage at the SFP input pin with 3.3V supply voltage. When the recommended supply filtering network is used, hot plugging of the SFP transceiver module will result in an inrush current of no more than 30 mA greater than the steady state value. VccR and VccT may be internally connected within the SFP transceiver module.
9. TD-/+: These are the differential transmitter inputs. They are AC-coupled, differential lines with 100 Ω differential termination inside the module. The AC coupling is done inside the module and is thus not required on the host board. The inputs will accept differential swings of 500 – 2400 mV (250 – 1200 mV single-ended), though it is recommended that values between 500 and 1200 mV differential (250 – 600 mV single-ended) be used for best EMI performance.

Mechanical Design Diagram

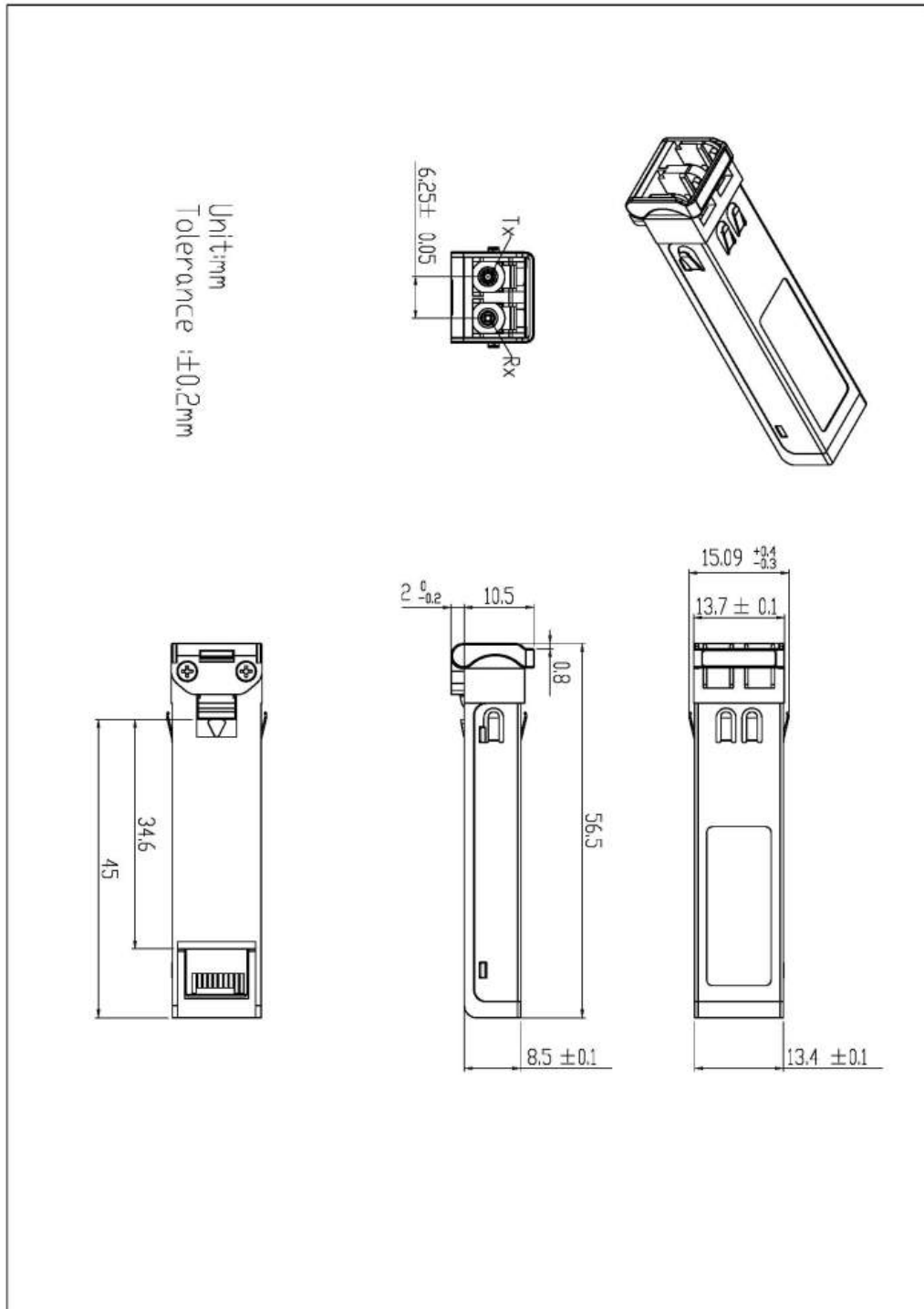



EEPROM Memory contents Address A0h

	AOI	A5WLSN85ADMA0541	E130	
Add	Name of field	Description	ACSII	HEX
0	Identifier	03:SFP or SFP "Plus" Transceiver		03
1	Ext. Identifier	SFP Transceiver		04
2	Connector	07:LC		07
3	Transceiver	10G Ethernet		00
4		SONET/SDH		00
5		SONET/SDH		00
6		Ethernet 01: 1000BASE-SX		01
7		Fiber Channel 20:intermediate distance		20
8		Fiber Channel 40:Shortwave laser		40
9		Fiber Channel 0C:Multimode,50um,62.5um		0C
10		Fiber Channel 15:1X/2X/4X FC		15
11	Encoding	01:8B 10B, 05:SONET,		01
12	BR, Nominal	100Mbps/unit -> HEX (2B:4.25G)		2B
13	Rate Identifier	Rate Select		00
14	Length(9um, km)	1km /unit -> HEX		00
15	Length (9um)	100m /unit -> HEX		00
16	Length (50um), OM2	10m /unit -> HEX 0F:150M		0F
17	Length (62.5um), OM1	10m /unit -> HEX 07:70M		07
18	Length (Copper)	1m /unit -> HEX		00
19	Length (50 um), OM3	10m /unit -> HEX		00
20	Vendor name	SFP Vendor Name (ASCII)	A	41
21			O	4F
22			I	49
23				20
24				20
25				20
26				20
27				20
28				20
29				20
30				20
31				20
32				20
33				20



SFP Dual LC 4.25G (Multi Rate) MMF 150m 850nm Transceiver

A5WLSN85ADMA0541

34				20
35				20
36	Reserved	Reserved		00
37				00
38	Vendor OUI	SFP Vendor IEEE company ID, No ID set "00"		00
39				00
40				A 41
41			5 35	
42			W 57	
43			L 4C	
44			S 53	
45			N 4E	
46			8 38	
47	Vendor PN	SFP Vendor Part Number (ASCII)	5	35
48			A	41
49			D	44
50			M	4D
51			A	41
52			0	30
53			5	35
54			4	34
55			1	31
56			A 41	
57	Vendor rev	Vendor Revision level (ASCII)		20
58				20
59				20
60	Wavelength	1nm /unit -> HEX		03
61				52
62	Wavelength	0.01nm /unit -> HEX		00
63	CC_BASE	Check Sum 0 to 62 byte		45
64				00
65	Options	18:TX-DIS,TX_Fault 1A:TX-DIS,TX_Fault,RX-LOS		1A
66	BR, max	1% /unit		00
67	BR, min	1% /unit		00
68				XX
69	Vendor SN	Vendor SN (ASCII)		XX
70				XX
71				XX



SFP Dual LC 4.25G (Multi Rate) MMF 150m 850nm Transceiver

A5WLSN85ADMA0541

72			XX
73			XX
74			XX
75			XX
76			XX
77			XX
78			XX
79			XX
80			XX
81			XX
82			XX
83			XX
84	Date code	Year (ASCII)	XX
85			XX
86		Month (ASCII)	XX
87			XX
88		Day (ASCII)	XX
89			XX
90		Blank	20
91			20
92	Diagnostic Monitoring Type	58:W/I DDM(Ext_Cal), 68:W/I DDM(Int_Cal)	58
93	Enhanced Options	E0:A/W, Tx_Dis, Tx_fault F0:A/W, Tx_Dis, Tx_fault, Rx_LOS	F0
94	SFF-8472 Compliance	01:9.3, 02:9.5, 03:10.2, 04:10.4	04
95	CC_EXT	Check Sum 64 to 94 byte	XX
96	Read-only		00
97			00
98			00
99			00
100			00
101			00
102			00
103			00
104			00
105			00
106			00
107			00
108			00
109			00



SFP Dual LC 4.25G (Multi Rate) MMF 150m 850nm Transceiver

A5WLSN85ADMA0541

110			00
111			00
112			00
113			00
114			00
115			00
116			00
117			00
118			00
119			00
120			00
121			00
122			00
123			00
124			00
125			00
126			00
127			00



SFP Dual LC 4.25G (Multi Rate) MMF 150m 850nm Transceiver

A5WLSN85ADMA0541

Module Label

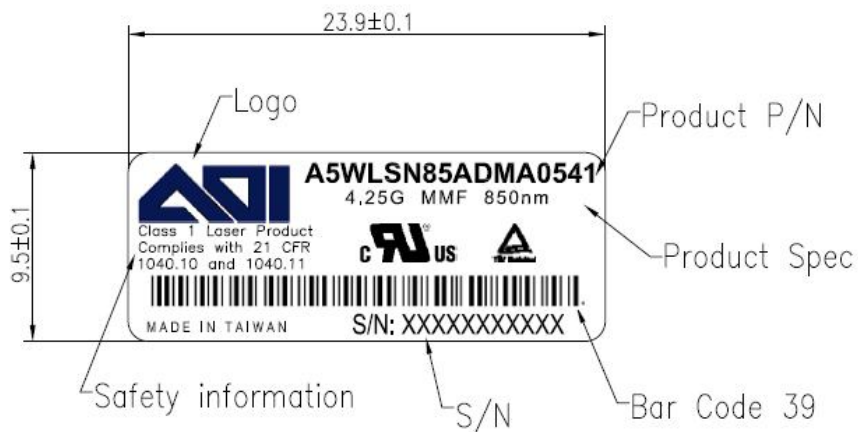

Unit:mm

S/N

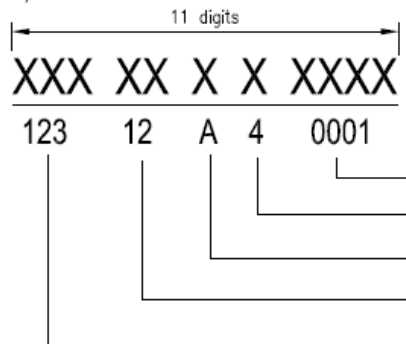

S/N :(0001~9999)
 Manufacturing order Type
 Month:Jan=A~Dec=L
 Year:ex:2012=12
 Manufacturing order number



Regulatory Compliance

Item	Standard
Electromagnetic Interference (EMI)	FCC Part 15 Class B EN55022 Class B (CISPR 22B) VCCI Class B
Electrostatic Discharge to the Electrical Pins (ESD)	MIL-STD-883E Method 3015.7
Electrostatic Discharge to the Receptacle (ESD)	IEC 61000-4-2
RoHS	2011/65/EU
Laser Eye Safety	FDA 21CFR 1040.10 and 1040.11
Component Recognition	UL and TUV

Laser Safety Information

All versions of this laser are Class 1 laser products per IEC¹/EN² 60825-1. Users should observe safety precautions such as those recommended by ANSI³ Z136.1-2000, ANSI Z36.2-1997 and IEC 60825-1.

This product conforms to FDA (CDRH) 21 CFR 1040.10 and 1040.11 except for deviations of laser safety class designation pursuant to [Laser Notice No.50](#)¹.

Product labeling:

Class 1 Laser Product
Compliance with 21 CFR
1040.10 and 1040.11

If labeling is not affixed to the module due to size constraints; then rather, labeling is placed on the outside of the shipping box.

This product is not shipped with a power supply.

Caution: use of controls or adjustments or performance of procedures other than those specified herein may result in hazardous radiation exposure.

Certifications

UL	60950-1 (E243407)
TUV	EN60950-1, EN 60825-1, EN 60825-2

Documentation is available upon request.

(1) IEC is a registered trademark of the International Electrotechnical Commission

(2) Within Europe the IEC standard has been adopted as a European Normative standard known as EN 60825, and each European country will have its own version of this standard, for example, the British Standards version known as BS EN 60825. There can be small differences between the different countries versions of EN 60825, and these are in part caused by the process of translating the standard into the native language of that country.

(3) ANSI is a registered trademark of the American National Standards Institute

Note : All information contained in this document is subject to change without notice.