

## SFP Dual LC 1.25G SMF 19dB CWDM Transceiver

A56L-FCxx-EDGA



### Applications

- ❑ Gigabit Ethernet (1.25Gbps)
- ❑ Fiber Channel 1xFC (1.0625Gbps)

### Features

- ❑ SFP Type Dual LC Transceiver
- ❑ Up to 20km point-to-point transmission
- ❑ CWDM DFB Laser
- ❑ PIN Photo Detector
- ❑ Link budget: 19dB transmission with SMF
- ❑ 3.3V single power supply
- ❑ Compliant with SFP MSA
- ❑ Compliant with IEEE 802.3ah, 802.3z
- ❑ Compliant with FC-PI-2
- ❑ Hot pluggable
- ❑ Serial ID information support
- ❑ Digital diagnostic SFF-8472 compliant
- ❑ Compliant with RoHS
- ❑ Compliant with UL & TUV



**SFP Dual LC 1.25G SMF 19dB CWDM Transceiver**

**A56L-FCxx-EDGA**

**Ordering Information**

Form Factor	Date Rate	Media	Link Budget	Wavelength (nm)	TX Power (dBm)	RX Sensitivity (dBm)	Voltage (V)	Coupling	Signal Detect	DDM (Y/N)	Temperature (°C)	Part Number
SFP-Dual-LC	1.25G	SMF	19dB	1270	-1 ~ 5	< -20	3.3	AC/AC	TTL	Y	-40 ~ +85	A56L-FC27-EDGA
SFP-Dual-LC	1.25G	SMF	19dB	1290	-1 ~ 5	< -20	3.3	AC/AC	TTL	Y	-40 ~ +85	A56L-FC29-EDGA
SFP-Dual-LC	1.25G	SMF	19dB	1310	-1 ~ 5	< -20	3.3	AC/AC	TTL	Y	-40 ~ +85	A56L-FC31-EDGA
SFP-Dual-LC	1.25G	SMF	19dB	1330	-1 ~ 5	< -20	3.3	AC/AC	TTL	Y	-40 ~ +85	A56L-FC33-EDGA
SFP-Dual-LC	1.25G	SMF	19dB	1350	-1 ~ 5	< -20	3.3	AC/AC	TTL	Y	-40 ~ +85	A56L-FC35-EDGA
SFP-Dual-LC	1.25G	SMF	19dB	1370	-1 ~ 5	< -20	3.3	AC/AC	TTL	Y	-40 ~ +85	A56L-FC37-EDGA
SFP-Dual-LC	1.25G	SMF	19dB	1390	-1 ~ 5	< -20	3.3	AC/AC	TTL	Y	-40 ~ +85	A56L-FC39-EDGA
SFP-Dual-LC	1.25G	SMF	19dB	1410	-1 ~ 5	< -20	3.3	AC/AC	TTL	Y	-40 ~ +85	A56L-FC41-EDGA
SFP-Dual-LC	1.25G	SMF	19dB	1430	-1 ~ 5	< -20	3.3	AC/AC	TTL	Y	-40 ~ +85	A56L-FC43-EDGA
SFP-Dual-LC	1.25G	SMF	19dB	1450	-1 ~ 5	< -20	3.3	AC/AC	TTL	Y	-40 ~ +85	A56L-FC45-EDGA
SFP-Dual-LC	1.25G	SMF	19dB	1470	-1 ~ 5	< -20	3.3	AC/AC	TTL	Y	-40 ~ +85	A56L-FC47-EDGA
SFP-Dual-LC	1.25G	SMF	19dB	1490	-1 ~ 5	< -20	3.3	AC/AC	TTL	Y	-40 ~ +85	A56L-FC49-EDGA
SFP-Dual-LC	1.25G	SMF	19dB	1510	-1 ~ 5	< -20	3.3	AC/AC	TTL	Y	-40 ~ +85	A56L-FC51-EDGA
SFP-Dual-LC	1.25G	SMF	19dB	1530	-1 ~ 5	< -20	3.3	AC/AC	TTL	Y	-40 ~ +85	A56L-FC53-EDGA
SFP-Dual-LC	1.25G	SMF	19dB	1550	-1 ~ 5	< -20	3.3	AC/AC	TTL	Y	-40 ~ +85	A56L-FC55-EDGA
SFP-Dual-LC	1.25G	SMF	19dB	1570	-1 ~ 5	< -20	3.3	AC/AC	TTL	Y	-40 ~ +85	A56L-FC57-EDGA
SFP-Dual-LC	1.25G	SMF	19dB	1590	-1 ~ 5	< -20	3.3	AC/AC	TTL	Y	-40 ~ +85	A56L-FC59-EDGA
SFP-Dual-LC	1.25G	SMF	19dB	1610	-1 ~ 5	< -20	3.3	AC/AC	TTL	Y	-40 ~ +85	A56L-FC61-EDGA



## SFP Dual LC 1.25G SMF 19dB CWDM Transceiver

A56L-FCxx-EDGA

## Absolute Maximum Ratings

Parameter	Symbol	Conditions	Min	Max	Unit
Storage Temperature	$T_S$	--	-40	+85	°C
Storage Relative Humidity	RH	--	5	95	%
Supply Voltage	$V_{CC}$	--	0	4.0	V

## Recommended Operating Conditions

Parameter	Symbol	Conditions	Min	Typ	Max	Unit
Operating Temperature (Case)	$T_C$	--	-40	--	85	°C
Supply Voltage	$V_{CC}$	--	3.1	3.3	3.5	V
Supply Current	$I_{TX} + I_{RX}$	--	--	--	400	mA
Data Rate	DR	--	--	1.25	--	Gbps

## Electrical Characteristics

Parameter	Symbol	Conditions	Min	Typ	Max	Unit
<b>Transmitter</b>						
Differential Input Impedance	$R_{DI}$	--	--	100	--	Ohm
Differential Input Voltage	$V_{DI}$	AC-Coupled, peak to peak	0.50	--	2.40	V
Tx Disable Input-High	$V_{DISH}$		2.0	--	$V_{CC}+0.3$	V
Tx Disable Input-Low	$V_{DISL}$		0	--	0.8	V
Tx Fault Output-High	$V_{FOH}$		2.0	--	$V_{CC}+0.3$	V
Tx Fault Output-Low	$V_{FOL}$		0	--	0.8	V
<b>Receiver</b>						
Differential Output Impedance	$R_{DO}$	--	--	100	--	Ohm
Differential Output Voltage	$V_{DO}$	AC-Coupled, peak to peak	0.37	--	2.00	V
Rx LOS Output-High	$V_{LOSH}$		2.00	--	$V_{CC}+0.3$	V
Rx LOS Output-Low	$V_{LOSL}$		0.00	--	0.80	V

## Optical Characteristics

Parameter	Symbol	Conditions	Min	Typ	Max	Unit
<b>Transmitter</b>						
Optical Center Wavelength	$\lambda_c$	--	$\lambda_c - 5.5$	$\lambda_c$	$\lambda_c + 7.5$	nm
Spectral Width	$\Delta\lambda$	(-20dB)	--	--	1	nm
Optical Output Power	$P_o$	Coupling into a 9/125um SMF	-1	--	+5	dBm
Side Mode Suppression Ratio	SMSR	--	30	--	--	dB
Optical Extinction Ratio	ER	--	9	--	--	dB
Optical Rise/Fall Time	$t_r / t_f$	20 % to 80% Values	--	--	0.26	ns
Output Eye	--	Compliant with IEEE802.3z and FC-PI-2				
<b>Receiver</b>						
Operating Wavelength	$\lambda$	--	1260	--	1620	nm
Receiver Overload	$P_{INMAX}$	1	0	--	--	dBm
Receiver Sensitivity	$P_{INMIN}$	1	--	--	-20	dBm
Rx LOS Assert	$P_A$	--	-35	--	--	dBm
Rx LOS De-Assert	$P_D$	--	--	--	-20	dBm
Rx LOS Hysteresis	$P_A - P_D$	--	0.5	--	--	dB

1. Measured with PRBS 2<sup>7</sup> -1 at 10<sup>-12</sup> BER

**Recommended Host Board Power Supply**

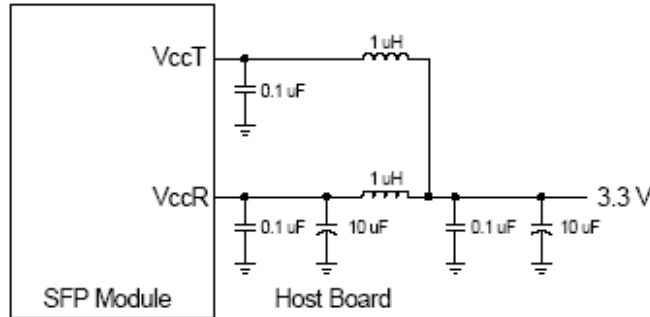

**Recommended Interface Circuit**

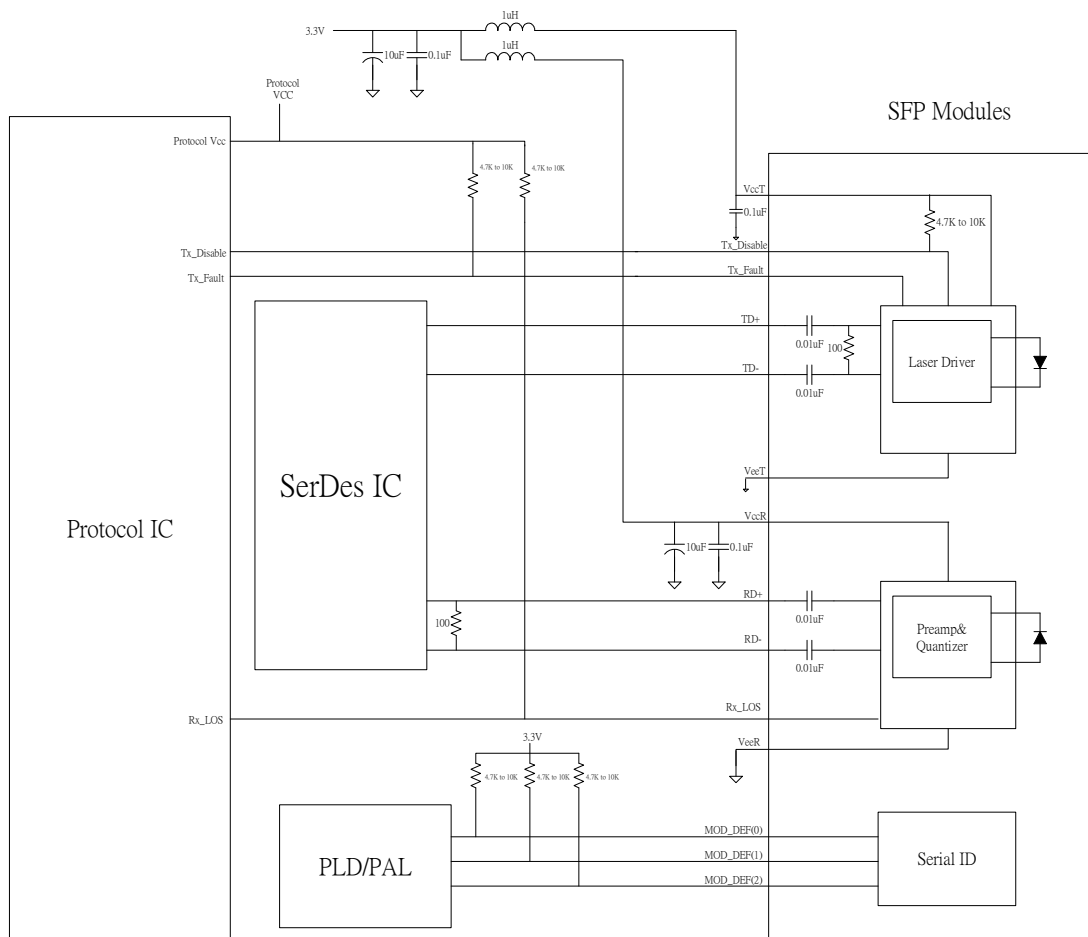

**Pin Description**

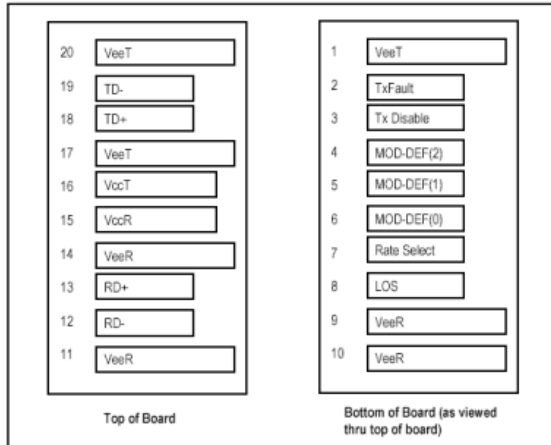

**SFP Transceiver Electric Pad Layout**

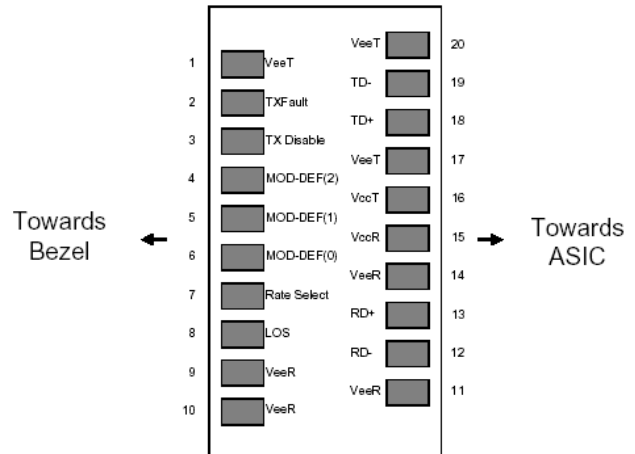

**Diagram of Host Board Connector Block Pin Numbers and Names**

**Pin Function Definitions**

Pin No.	Pin Name	Function	Plug Seq.	Note
1	VeeT	Transmitter Ground	1	
2	TX Fault	Transmitter Fault Indication	3	1
3	TX Disable	Transmitter Disable	3	2
4	MOD_DEF 2	Module Definition 2	3	3
5	MOD_DEF 1	Module Definition 1	3	3
6	MOD_DEF 0	Module Definition 0	3	3
7	Rate Select	Select between full or reduced receiver bandwidth	3	4
8	LOS	Loss of Signal	3	5
9	VeeR	Receiver Ground	1	6
10	VeeR	Receiver Ground	1	6
11	VeeR	Receiver Ground	1	6
12	RD -	Inv. Receiver Data Out	3	7
13	RD +	Receiver Data Out	3	7
14	VeeR	Receiver Ground	1	6
15	VccR	Receiver Power	2	8
16	VccT	Transmitter Power	2	8
17	VeeT	Transmitter Ground	1	6
18	TD +	Transmitter Data In	3	9
19	TD -	Inv. Transmitter Data In	3	9
20	VeeT	Transmitter Ground	1	6

**Notes:**

Plug Seq.: Pin engagement sequence during hot plugging.

1. TX Fault is an open collector/drain output, which should be pulled up with a 4.7K – 10K $\Omega$  resistor on the host board. Pull up voltage between 2.0V and VccT, R+0.3V. When high, output indicates a laser fault of some kind. Low indicates normal operation. In the low state, the output will be pulled to < 0.8V.
2. TX disable is an input that is used to shut down the transmitter optical output. It is pulled up within the module with a 4.7 – 10 K $\Omega$  resistor. Its states are:
  - Low (below 0.8V): Transmitter on
  - (>0.8, < 2.0V): Undefined
  - High (above 2.0v): Transmitter Disabled
  - Open: Transmitter Disabled
3. Mod-Def 0,1,2. These are the module definition pins. They should be pulled up with a 4.7K - 10K $\Omega$  resistor on the host board. The pull-up voltage shall be VccT or VccR
  - Mod-Def 0 is grounded by the module to indicate that the module is present
  - Mod-Def 1 is the clock line of two wire serial interface for serial ID
  - Mod-Def 2 is the data line of two wire serial interface for serial ID
4. No connection
5. LOS (Loss of Signal) is an open collector/drain output, which should be pulled up with a 4.7K -10K $\Omega$  resistor on the host board. Pull up voltage between 2.0V and VccT, R+0.3V. When high, this output indicates the received optical power is below the worst-case receiver sensitivity (as defined by the standard in use). Low indicates normal operation. In the low state, the output will be pulled to < 0.8V.
6. VeeR and VeeT may be internally connected within the SFP module.
7. RD-/+: These are the differential receiver outputs. They are AC coupled 100 $\Omega$  differential lines which should be terminated with 100 $\Omega$  (differential) at the user SERDES. The AC coupling is done inside the module and is thus not required on the host board. The voltage swing on these lines will be between 370 and 2000 mV differential (185 – 1000 mV single ended) when properly terminated.
8. VccR and VccT are the receiver and transmitter power supplies. Maximum supply current is 300 mA. Recommended host board power supply filtering is shown below. Inductors with DC resistance of less than 1 $\Omega$  should be used in order to maintain the required voltage at the SFP input pin with 3.3V supply voltage. When the recommended supply filtering network is used, hot plugging of the SFP transceiver module will result in an inrush current of no more than 30 mA greater than the steady state value. VccR and VccT may be internally connected within the SFP transceiver module.
9. TD-/+: These are the differential transmitter inputs. They are AC-coupled, differential lines with 100 $\Omega$  differential termination inside the module. The AC coupling is done inside the module and is thus not required on the host board. The inputs will accept differential swings of 500 – 2400 mV (250 – 1200 mV single-ended), though it is recommended that values between 500 and 1200 mV differential (250 – 600 mV single-ended) be used for best EMI performance.

Mechanical Design Diagram (mm)

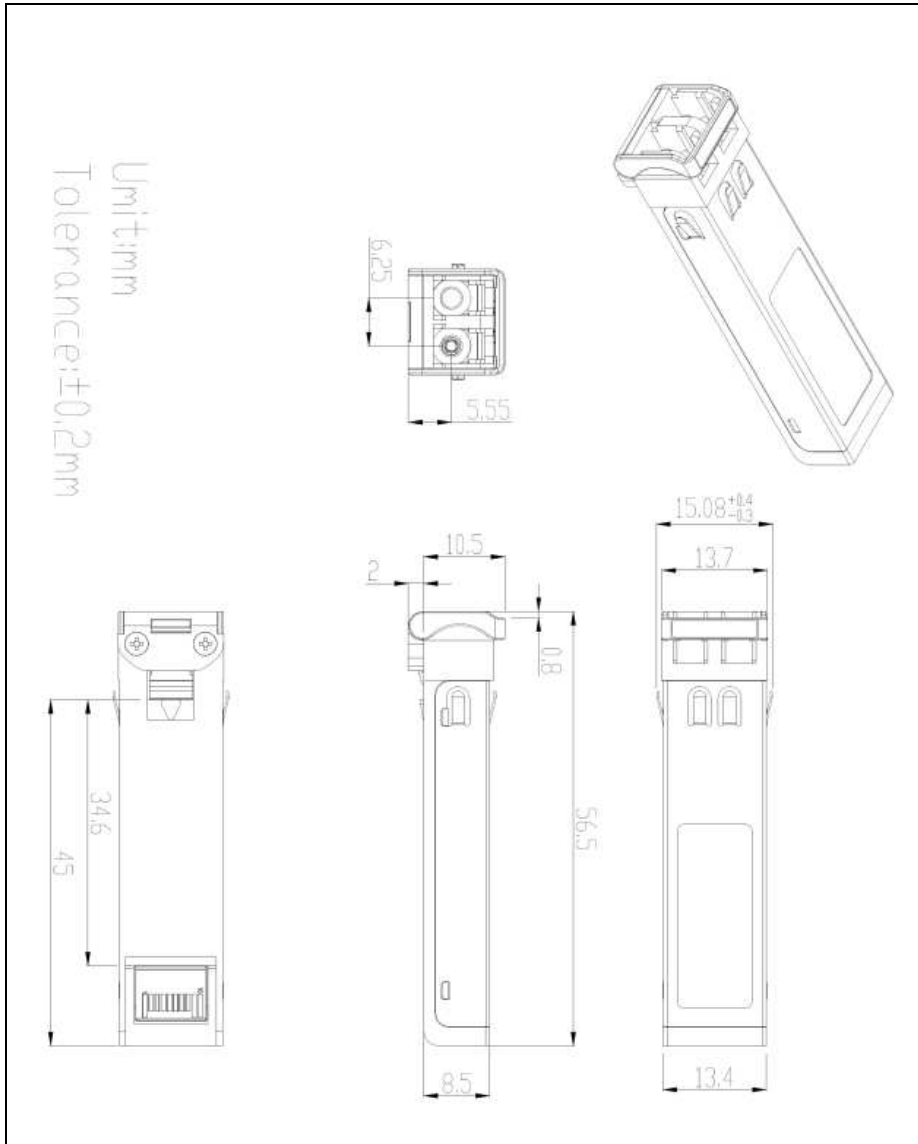



**Regulatory Compliance**

Item	Standard
Electromagnetic Interference (EMI)	FCC Part 15 Class B EN55022 Class B (CISPR 22B) VCCI Class B
Electrostatic Discharge to the Electrical Pins (ESD)	MIL-STD-883E Method 3015.7
Electrostatic Discharge to the Receptacle (ESD)	IEC 61000-4-2
RoHS	2011/65/EU
Laser Eye Safety	FDA 21CFR 1040.10 and 1040.11
Component Recognition	UL and TUV

**Laser Safety Information**

All versions of this laser are Class 1 laser products per IEC<sup>1</sup>/EN<sup>2</sup> 60825-1. Users should observe safety precautions such as those recommended by ANSI<sup>3</sup> Z136.1, ANSI Z36.2 and IEC 60825-1.

This product conforms to FDA (CDRH) 21 CFR 1040.10 and 1040.11 except for deviations of laser safety class designation pursuant to 'Laser Notice No.50' .

Product labeling:

Class 1 Laser Product  
Compliance with 21 CFR  
1040.10 and 1040.11

If labeling is not affixed to the module due to size constraints; then rather, labeling is placed on the outside of the shipping box.

This product is not shipped with a power supply.

**Caution: use of controls or adjustments or performance of procedures other than those specified herein may result in hazardous radiation exposure.**

**Certifications**

UL	60950-1 (E243407)
TUV	EN60950-1, EN 60825-1, EN 60825-2

Documentation is available upon request.

(1) IEC is a registered trademark of the International Electrotechnical Commission

(2) Within Europe the IEC standard has been adopted as a European Normative standard known as EN 60825, and each European country will have its own version of this standard, for example, the British Standards version known as BS EN 60825. There can be small differences between the different countries versions of EN 60825, and these are in part caused by the process of translating the standard into the native language of that country.

(3) ANSI is a registered trademark of the American National Standards Institute

Note : All information contained in this document is subject to change without notice.