

**SFP+ Dual LC 10G MMF 300m 850nm Transceiver**

**A7EL-SN85-ADMA**



**Applications**

- ❑ 10GBASE-SR Ethernet (9.95 to 10.31Gbps)
- ❑ 1200-Mx-SN-I 10G Fiber Channel

**Features**

- ❑ SFP+ Type Dual LC Transceiver
- ❑ 850nm VCSEL Laser
- ❑ PIN Photo Detector
- ❑ 300m transmission with OM3 MMF
- ❑ 82m transmission with OM2 MMF
- ❑ 33m transmission with OM1 MMF
- ❑ 3.3V single power supply
- ❑ Compliant with SFP+ MSA
- ❑ Compliant with IEEE 802.3ae
- ❑ Hot pluggable
- ❑ Serial ID information support
- ❑ Digital diagnostic SFF-8472 compliant
- ❑ Compliant with RoHS
- ❑ Compliant with UL & TUV
- ❑ Compliant with American National Standard for Information Technology – Fiber Channel – 10 Gigabit Fiber Channel, Rev 4.0, April 1, 2004

**Ordering Information**

Form Factor	Date Rate	Media	Distance	Wavelength (nm)	TX Power (dBm)	RX Sensitivity (dBm)	Voltage (V)	Coupling	Signal Detect	DDM (Y/N)	Temperature (°C)	Part Number
SFP+ Dual-LC	10G	MMF	300m	850	-7.3 ~ -1	< -9.9	3.3	AC/AC	TTL	Y	-5 ~ +70	A7EL-SN85-ADMA

**SFP+ Dual LC 10G MMF 300m 850nm Transceiver**
**A7EL-SN85-ADMA**
**Absolute Maximum Ratings**

Parameter	Symbol	Conditions	Min	Max	Unit
Storage Temperature	$T_S$	--	-40	+85	°C
Storage Relative Humidity	RH	--	5	95	%
Supply Voltage	$V_{CC}$	--	0	4.0	V

**Recommended Operating Conditions**

Parameter	Symbol	Conditions	Min	Typ	Max	Unit
Operating Temperature (Case)	$T_C$	--	-5	--	70	°C
Supply Voltage	$V_{CC}$	--	3.14	3.3	3.46	V
Supply Current	$I_{TX} + I_{RX}$	--	--	--	300	mA
Data Rate	DR	--	9.95	10.31	--	Gbps

**Electrical Characteristics**

Parameter	Symbol	Conditions	Min	Typ	Max	Unit
<b>Transmitter</b>						
Differential Input Impedance	$R_{DI}$	--	--	100	--	Ohm
Differential Input Voltage	$V_{DI}$	AC-Coupled, peak to peak	120	--	1000	mV
Tx Disable Input-High	$V_{DISH}$	--	2.0	--	$V_{CC}+0.3$	V
Tx Disable Input-Low	$V_{DISL}$	--	0	--	0.8	V
Tx Fault Output-High	$V_{FOH}$	--	2.0	--	$V_{CC}+0.3$	V
Tx Fault Output-Low	$V_{FOL}$	--	0	--	0.8	V
<b>Receiver</b>						
Differential Output Impedance	$R_{DO}$	--	--	100	--	Ohm
Differential Output Voltage	$V_{DO}$	1	400	--	800	mV
Rx LOS Output-High	$V_{LOSH}$	--	2.00	--	$V_{CC}+0.3$	V
Rx LOS Output-Low	$V_{LOSL}$	--	0.00	--	0.80	V

1. AC-Coupled, peak to peak ; 400 mV is Typical Minimum and 800 mV is Typical Maximum

**Optical Characteristics**

( $V_{CC}=3.14V$  to  $3.46V$ , 50/125um MMF)

Parameter	Symbol	Conditions	Min	Typ	Max	Unit
<b>Transmitter</b>						
Optical Center Wavelength	$\lambda_c$	--	840	850	860	nm
Spectral Width	$\Delta\lambda$	(RMS) Refer to Table1	--	--	0.45	nm
Optical Output Power	$P_o$	(Avg.)	-7.3	--	-1	dBm
Optical Extinction Ratio	ER	--	3	--	--	dB
Optical Modulation Amplitude	OMA	--	Refer to Table1, Figure1			dBm
Relative Intensity Noise	$RIN_{12}OMA$	--	--	--	-128	dB/Hz
Eye Mask	--	Compliant with IEEE 802.3ae				
<b>Receiver</b>						
Operating Wavelength	$\lambda$	--	840	850	860	nm
Receiver Overload	$P_{IN}MAX$	1	-1	--	--	dBm
Rx Sensitivity (Avg.) @10.31Gbps	$P_{IN}MIN$	1	--	--	-9.9	dBm
Rx Sensitivity (OMA) @10.31Gbps	$P_{IN}MIN$	1	--	--	-11.1	dBm
Rx LOS Assert	$LOS_A$	--	-30	--	--	dBm
Rx LOS De-Assert	$LOS_D$	--	--	--	-12	dBm
Rx LOS Hysteresis	--	--	0.5	--	--	dB
Receiver Reflectance	--	--	--	--	-12	dB

41. Measured with PRBS  $2^{31}-1$  at  $10^{-12}$  BER



**SFP+ Dual LC 10G MMF 300m 850nm Transceiver**

**A7EL-SN85-ADMA**

**Table 1—Minimum 10GBASE-S optical modulation amplitude (dBm) as a function of center wavelength and spectral width**

Center Wavelength (nm)	RMS Spectral width (nm)								
	Up to 0.05	0.05 to 0.1	0.1 to 0.15	0.15 to 0.2	0.2 to 0.25	0.25 to 0.3	0.3 to 0.35	0.35 to 0.4	0.4 to 0.45
840 to 842	-4.2	-4.2	-4.1	-4.1	-3.9	-3.8	-3.5	-3.2	-2.8
842 to 844	-4.2	-4.2	-4.2	-4.1	-3.9	-3.8	-3.6	-3.3	-2.9
844 to 846	-4.2	-4.2	-4.2	-4.1	-4.0	-3.8	-3.6	-3.3	-2.9
846 to 848	-4.3	-4.2	-4.2	-4.1	-4.0	-3.8	-3.6	-3.3	-2.9
848 to 850	-4.3	-4.2	-4.2	-4.1	-4.0	-3.8	-3.6	-3.3	-3.0
850 to 852	-4.3	-4.2	-4.2	-4.1	-4.0	-3.8	-3.6	-3.4	-3.0
852 to 854	-4.3	-4.2	-4.2	-4.1	-4.0	-3.9	-3.7	-3.4	-3.1
854 to 856	-4.3	-4.3	-4.2	-4.1	-4.0	-3.9	-3.7	-3.4	-3.1
856 to 858	-4.3	-4.3	-4.2	-4.1	-4.0	-3.9	-3.7	-3.5	-3.1
858 to 860	-4.3	-4.3	-4.2	-4.2	-4.1	-3.9	-3.7	-3.5	-3.2

**Figure 1—Triple tradeoff curve for 10GBASE-S (informative)**

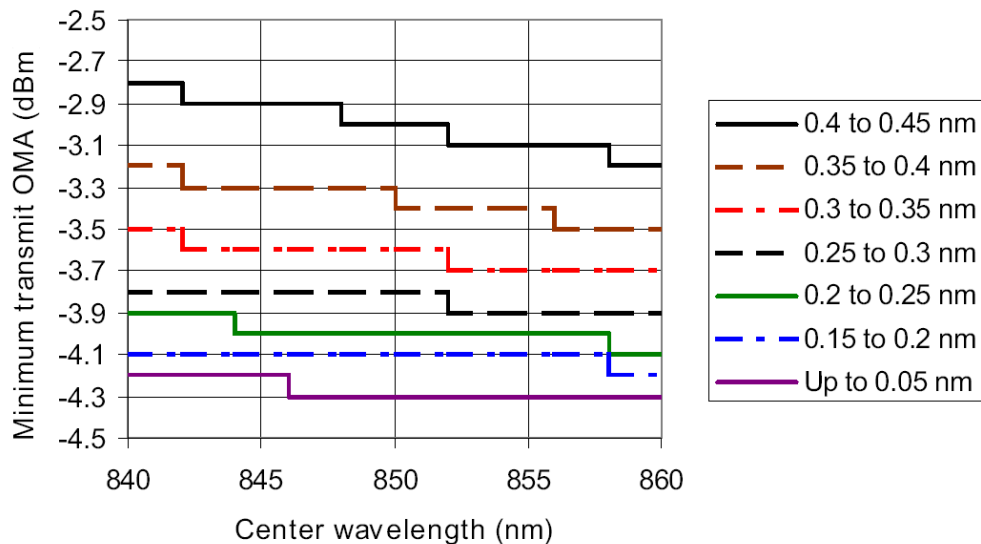

**Recommended Interface Circuit**

**SFP+ Dual LC 10G MMF 300m 850nm Transceiver**

**A7EL-SN85-ADMA**

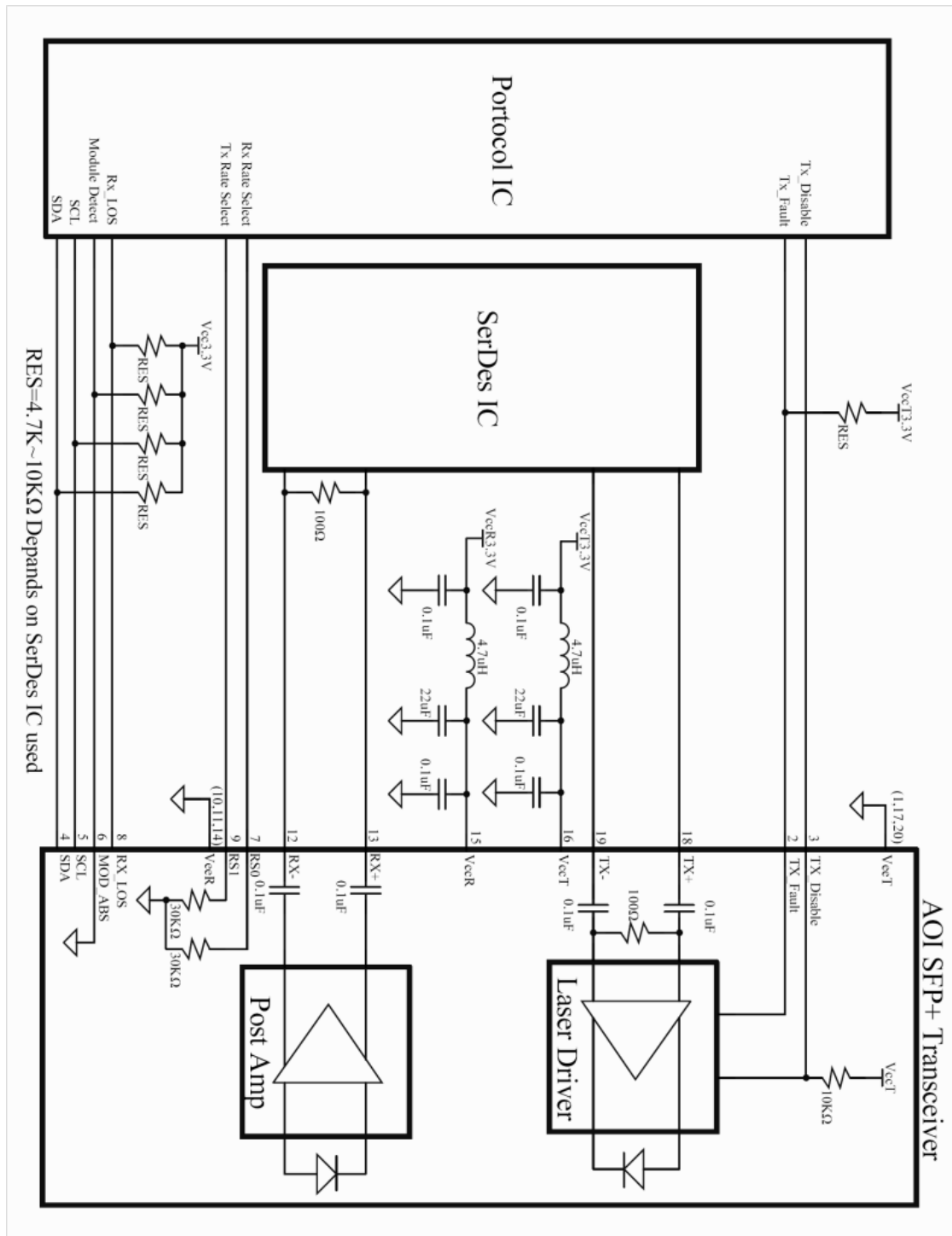

**Pin Description**

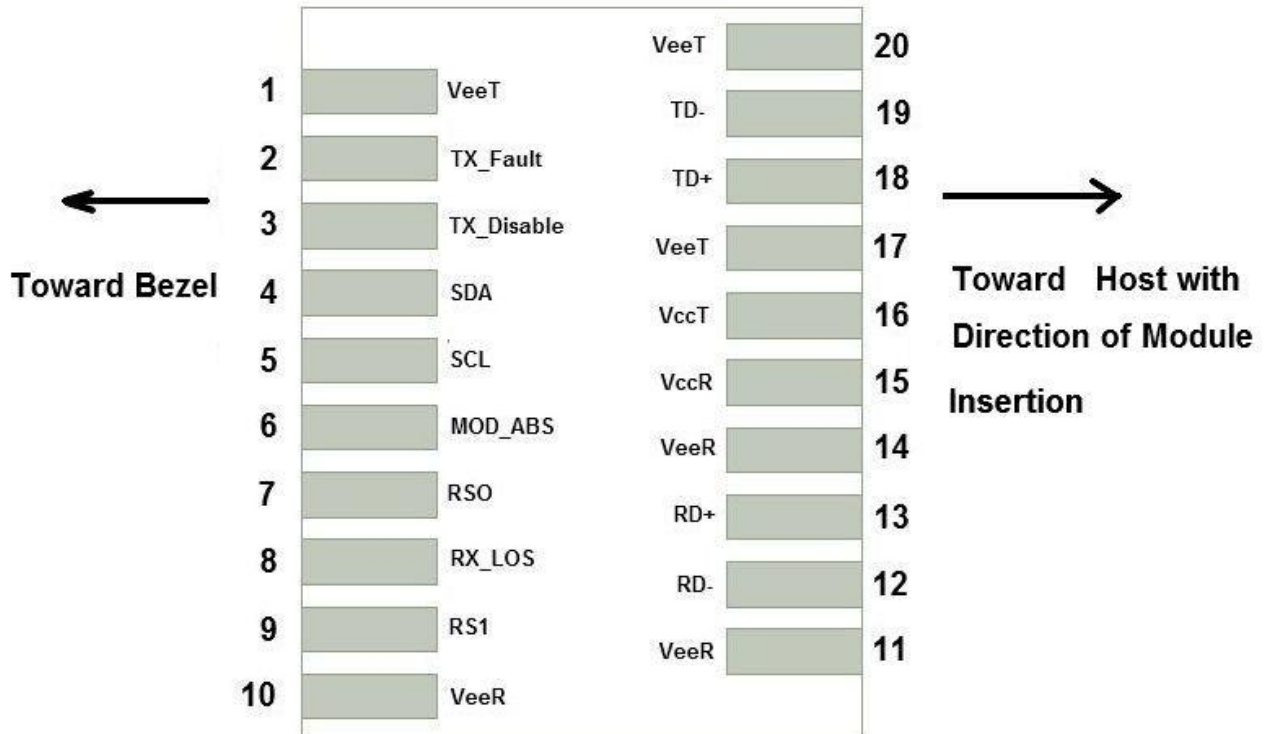

## Pin Function Definitions

Pin No.	Pin Name	Function/Description	Power Sequence Order	Note
1	VeeT	Transmitter Ground	1	1
2	Tx_Fault	Transmitter Fault	3	2
3	Tx_Disable	Transmitter Disable; Turns off transmitter laser output	3	3
4	SDA	2-wire Serial Interface Data Line (MOD-DEF2)	3	4
5	SCL	2-wire Serial Interface Clock (MOD-DEF1)	3	4
6	Mod_ABS	Module Absent, connected to VeeT or VeeR in the module	3	4
7	RS0	Rate Select 0, (not functional)	3	
8	Rx_LOS	Receiver Loss of Signal Indication	3	2
9	RS1	Rate Select 1, (not functional)	3	
10	VeeR	Receiver Ground	1	1
11	VeeR	Receiver Ground	1	1
12	RD-	Receiver Inverted Data Output	3	
13	RD+	Receiver Non-Inverted Data Output	3	
14	VeeR	Module Receiver Ground	1	1
15	VccR	Receiver 3.3 V Supply	2	
16	VccT	Transmitter 3.3 V Supply	2	
17	VeeT	Transmitter Ground	1	1
18	TD+	Transmitter Non-Inverted Data Input	3	
19	TD-	Transmitter Inverted Data Input	3	
20	VeeT	Transmitter Ground	1	1

### Notes:

1. The module signal ground contacts, VeeR and VeeT, should be isolated from the module case.
2. This contact is an open collector/drain output contact and shall be pulled up with a 4.7k to 10k Ohms resistor to host\_Vcc on the host board. Pull ups can be connected to one of several power supplies, however the host board design shall ensure that no module contact has voltage exceeding module VccT/R + 0.5 V. Low for normal operation.
3. This contact is an input contact with a 4.7 kΩ to 10k Ohms pull up to VccT inside the module. Low for enable and High for disable.
4. This contact shall be pulled up with a 4.7k to 10k Ohms resistor to host\_Vcc on the host board. Mod\_ABS grounded by the module to indicate that the module is present. Mod\_ABS grounded by the module to indicate that the module is present.

**SFP+ Dual LC 10G MMF 300m 850nm Transceiver**

**A7EL-SN85-ADMA**

**Mechanical Design Diagram**

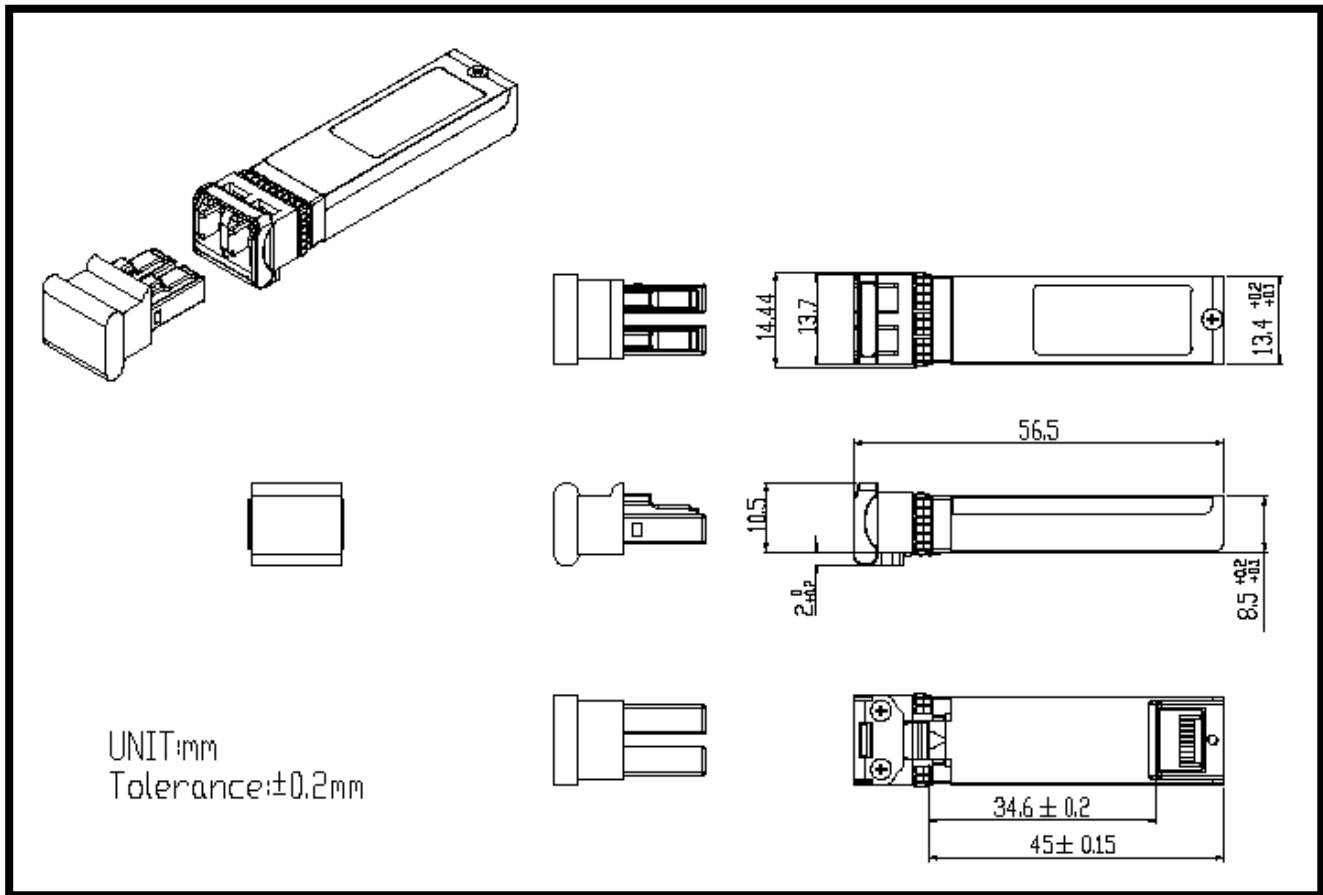



**SFP+ Dual LC 10G MMF 300m 850nm Transceiver**

**A7EL-SN85-ADMA**

**EEPROM—Serial ID Memory Contents (A0h)**

Vendor Name			AOI	
Vendor Part Number			A7EL-SN85-ADMA	
Address	Name of field	Description	Hex	ASCII
<b>BASE ID FIELDS</b>				
0	Identifier	SFP Transceiver	03	
1	Ext. Identifier	SFP Transceiver	04	
2	Connector	01:SC, 07:LC	07	
3	Transceiver	Infiniband	10	
4		SONET/SDH	00	
5		SONET/SDH	00	
6		Ethernet	00	
7		Fiber Channel	00	
8		Fiber Channel	00	
9		Fiber Channel	00	
10		Fiber Channel	00	
11		Encoding	01:8B10B, 02:4B5B, 03:NRZ, 05:SONET	06
12	BR, Nominal	100Mbps/unit -> HEX	67	
13	Reserved	Reserved	00	
14	Length(9um, km)	1km /unit -> HEX	00	
15	Length (9um), OM2	100m /unit -> HEX	00	
16	Length (50um), OM1	10m /unit -> HEX	08	
17	Length (62.5um)	10m /unit -> HEX	03	
18	Length (Copper)	1m /unit -> HEX	00	
19	Length (50 um), OM3	10m /unit -> HEX	1E	
20	Vendor name	Vendor Name (ASCII)	41	A
21			4F	O
22			49	I
23			20	
24			20	
25			20	
26			20	
27			20	
28			20	
29			20	
30			20	
31			20	





**SFP+ Dual LC 10G MMF 300m 850nm Transceiver**

**A7EL-SN85-ADMA**

32			20	
33			20	
34			20	
35			20	
36	Reserved	Reserved	00	
37	Vendor OUI	SFP Vendor IEEE company ID, No ID set "00"	00	
38			00	
39			00	
40	Vendor PN	Vendor Part Number (ASCII)	41	A
41			37	7
42			45	E
43			4C	L
44			2D	-
45			53	S
46			4E	N
47			38	8
48			35	5
49			2D	-
50			41	A
51			44	D
52			4D	M
53			41	A
54			20	
55			20	
56	Vendor rev	Vendor Revision level (ASCII)	41	A
57			20	
58			20	
59			20	
60	Wavelength	Wavelength -> HEX	03	
61			52	
62	Reserved		00	
63	CC_BASE	Check Sum 0 to 62 byte	E7	
<b>EXTENDED ID FIELDS</b>				
64	Options		00	
65		18:TX-DIS,TX_Fault 1A:TX-DIS,TX_Fault,RX-LOS	1A	
66	BR, max	1% /unit	00	
67	BR, min	1% /unit	00	



**SFP+ Dual LC 10G MMF 300m 850nm Transceiver**

**A7EL-SN85-ADMA**

68	Vendor SN	Vendor SN (ASCII)	XX	
69			XX	
70			XX	
71			XX	
72			XX	
73			XX	
74			XX	
75			XX	
76			XX	
77			XX	
78			XX	
79			XX	
80			XX	
81			XX	
82			XX	
83			XX	
84	Date code	Year (ASCII)	XX	
85		XX		
86		Month (ASCII)	XX	
87		XX		
88		Day (ASCII)	XX	
89		XX		
90		Blank	20	
91	20			
92	Diagnostic Monitoring Type	00:W/O DDM, 58:W/I DDM(Ext_Cal), 68:W/I DDM(Int_Cal), 78:W/I DDM(Int+Ext_Cal)	68	
93	Enhanced Options	00:W/O DDM, F0:W/I DDM	F0	
94	SFF-8472 Compliance	01:9.3, 02:9.5, 03:10.2	03	
95	CC_EXT	Check Sum 64 to 94 byte	XX	
<b>VENDOR SPECIFIC ID FIELDS</b>				
96-127	Read-only		00	



**SFP+ Dual LC 10G MMF 300m 850nm Transceiver**

**A7EL-SN85-ADMA**

**Product Label Drawing**

**A7EL-SN85-ADMA**  
**10G MMF 850nm**

Class 1 Laser Product  
 Complies with 21 CFR  
 1040.10 and 1040.11

**CUL US** **TUV Rheinland**

**MADE IN TAIWAN** **S/N: 88812B10080**

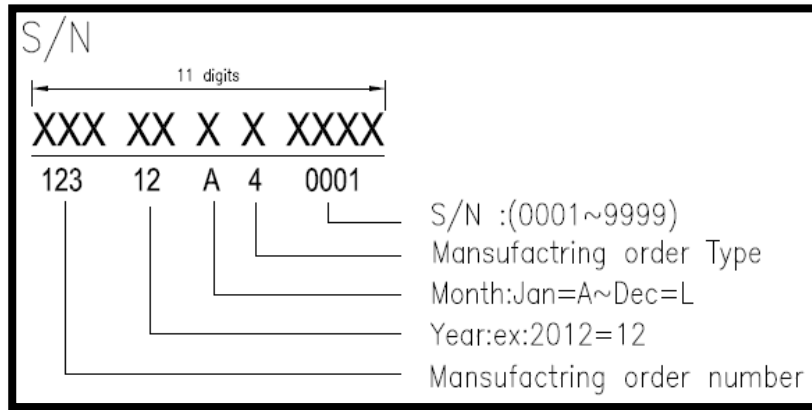

## Regulatory Compliance

Item	Standard
Electromagnetic Interference (EMI)	FCC Part 15 Class B EN55022 Class B (CISPR 22B) VCCI Class B
Electrostatic Discharge to the Electrical Pins (ESD)	MIL-STD-883E Method 3015.7
Electrostatic Discharge to the Receptacle (ESD)	IEC 61000-4-2
RoHS	2011/65/EU
Laser Eye Safety	FDA 21CFR 1040.10 and 1040.11
Component Recognition	UL and TUV

## Laser Safety Information

All versions of this laser are Class 1 laser products per IEC1/EN2 60825-1:2007. Users should observe safety precautions such as those recommended by ANSI<sup>3</sup> Z136.1-2000, ANSI Z36.2-1997 and IEC 60825-1:2007.

This product conforms to FDA (CDRH) 21 CFR 1040.10 and 1040.11 except for deviations of laser safety class designation pursuant to '[Laser Notice No.50](#)', dated June 24, 2007

Product labeling:

Class 1 Laser Product  
Compliance with 21 CFR  
1040.10 and 1040.11

If labeling is not affixed to the module due to size constraints; then rather, labeling is placed on the outside of the shipping box.

This product is not shipped with a power supply.

**Caution: use of controls or adjustments or performance of procedures other than those specified herein may result in hazardous radiation exposure.**

## Certifications

<b>UL</b>	<b>60950-1 (E243407)</b>
<b>TUV</b>	<b>EN60950-1: A12:2011, EN 60825-1, EN 60825-2</b>

Documentation is available upon request.

(1) IEC is a registered trademark of the International Electrotechnical Commission

(2) Within Europe the IEC standard has been adopted as a European Normative standard known as EN 60825, and each European country will have its own version of this standard, for example, the British Standards version known as BS EN 60825. There can be small differences between the different countries versions of EN 60825, and these are in part caused by the process of translating the standard into the native language of that country.

(3) ANSI is a registered trademark of the American National Standards Institute

Note : All information contained in this document is subject to change without notice.